

DATA SHEET

25 FRAME PLUNGER PUMPS



**Brass
Models**

2530, 2530E

**Stainless Steel
Model**

2531

**Flushed Stainless
Steel Model**

2531C

**Nickel Aluminum
Bronze Model**

2537



Model 2530 Shown
(Shaft protector and mounting rails sold separately)

FEATURES

- Triplex plunger design ensures high efficiency and low pulsation.
- High-pressure and low-pressure seals are completely lubricated and cooled by pumped liquid, greatly increasing service life.
- Belt-driven option provides precise flow setting.
- Direct-drive option offers a compact footprint for SAE hydraulic motors with a bell housing/flexible coupler assembly.
- Model 2531C offers an external flush for high-temperature or low-lubricity liquids.
- Pump comes standard with NBR seals. Alternative seal materials are available for higher temperature or chemical compatibility.

SPECIFICATIONS	U.S.	Metric
Flow	25 gpm	95 lpm
Pressure Range	100–1200 psi	6.9–83 bar
Pump RPM*	1025 rpm	1025 rpm
Inlet Pressure Range	Flooded to 70 psi	Flooded to 4.8 bar
Max. Liquid Temp. (NBR)	160° F	71° C
Alternative seals available for higher temperatures up to 200° F		
Bore	1.260"	32 mm
Stroke	1.516"	38.5 mm
Crankcase Capacity	84 oz	2.5 l
Inlet Ports (2)	1¼" NPT(F)	1¼" NPT (F)
Flush Ports (2) (2531C)	¼" NPT (F)	¼" NPT (F)
Discharge Ports (2)	¾" NPT (F)	¾" NPT (F)
Shaft Diameter	1.181"	30 mm
Pulley Mounting	Either Side	Either Side
Weight	68.3 lbs	31 kg
Dimensions	19.43 x 15.04 x 7.80"	493 x 382 x 198 mm

*Pump minimum is 100 RPM.

ALTERNATIVE SEAL CONFIGURATION

MATERIAL	SUFFIX CODE	MAXIMUM TEMPERATURE	
NBR	—	160° F	(71° C)
FPM	.0110	180° F	(82° C)
EPDM	.0220	160° F	(71° C)
FFKM	.0770	200° F	(93° C)
HT	.3000	180° F	(82° C)
STHT	.3400	190° F	(88° C)

See **Tech Bulletin 002** for inlet conditions and RPM at high-temperature.

$$\frac{\text{DETERMINING THE PUMP RPM}}{\text{Rated rpm}} = \frac{\text{Desired gpm}}{\text{Desired rpm}}$$

$$\frac{\text{DETERMINING THE REQUIRED HP}}{\text{hp (Electric Brake)}} = \frac{\text{gpm} \times \text{psi}}{1460}$$

$$\frac{\text{DETERMINING MOTOR PULLEY SIZE}}{\text{Motor Pulley OD}} = \frac{\text{Pump Pulley OD}}{\text{Motor rpm}}$$

Refer to pump **Service Manual** for repair procedure and additional technical information.

PARTS LIST

ITEM	PART		PART		PART		DESCRIPTION	QTY
	NUMBER	MATL	NUMBER	MATL	NUMBER	MATL		
	2530, 2530E		2531, 2531C		2537			
5	126544	STCPR	125753	S	125753	S	Screw, HHC, Sems (M8 x 25) (See Tech Bulletin 074)	8
	125753	S	—	—	—	—	Screw, HHC, Sems (M8 x 25) (Model 2530E) (See Tech Bulletin 074)	8
8	134966	ALE	134966	ALE	134966	ALE	Cover, Bearing (See Tech Bulletins 118,135)	2
10	27772	NBR	27772	NBR	27772	NBR	O-Ring, Oil Seal Case-70D	2
11	27771	NBR	27771	NBR	27771	NBR	Seal, Oil, Crankshaft	2
15	26512	STLR	26512	STLR	26512	STLR	Bearing, Ball	2
20	48613	TNM	48613	TNM	48613	TNM	Assembly, Rod, Connecting (Includes: Lockwasher, Washer, Screws) (See Tech Bulletin 074)	3
21	126562	STCPR	126562	STCPR	126562	STCPR	Washer, Locking	3
25	49795	FCM	49795	FCM	49795	FCM	Crankshaft – Dual End (M38.5)	1
32	43211	ABS	43211	ABS	43211	ABS	Cap, Oil Filler	1
33	14177	NBR	14177	NBR	14177	NBR	O-Ring, Oil Filler Cap-70D	1
36	129343	RBR	129343	RBR	129343	RBR	Gasket, Flat	1
37	92241	PC	92241	PC	92241	PC	Gauge, Bubble, Oil with Gasket-80D (See Tech Bulletin 074)	1
38	44428	NBR	44428	NBR	44428	NBR	Gasket, Flat, Oil Gauge-80D	1
39	27769	ABS	27769	ABS	27769	ABS	Dipstick	1
40	126544	STCPR	125753	S	125753	S	Screw, HHC, Sems (M8 x 25) (See Tech Bulletin 074)	8
	125753	S	—	—	—	—	Screw, HHC, Sems (M8 x 25) (Model 2530E) (See Tech Bulletin 074)	8
48	25625	STCP	25625	STCP	25625	STCP	Plug, Drain (1/4" x 19 BSP)	1
49	23170	NBR	23170	NBR	23170	NBR	O-Ring, Drain Plug-70D	1
50	133582	ALE	133582	ALE	133582	ALE	Cover, Rear (See Tech Bulletins 118, 126)	1
51	27767	NBR	27767	NBR	27767	NBR	O-Ring, Rear Cover-70D	1
53	133609	ALE	133609	ALE	133609	ALE	Crankcase Assembly (Includes: 54) (See Tech Bulletins 118, 135)	1
54	27488	S	27488	S	27488	S	Pin, Guide	2
56	27790	POP	27790	POP	27790	POP	Pan, Oil	1
57	22981	STCPR	22981	STCPR	22981	STCPR	Washer, Oil Pan	2
59	125824	STCPR	92538	S	92538	S	Screw, HHC, Sems (M6 x 16)	2
	92538	S	—	—	—	—	Screw, HHC, Sems (M6 x 16) (Model 2530E)	2
64	27784	CM	27784	CM	27784	CM	Pin, Crosshead	3
65	† 48719	SSHS	48719	SSHS	48719	SSHS	Rod, Plunger	3
70	27785	NBR	27785	NBR	27785	NBR	Seal, Crankcase Oil	3
75	110669	S	110669	S	110669	S	Slinger, Barrier	3
88	110670	S	110670	S	110670	S	Washer, Keyhole	3
90	45749	CC	45749	CC	45749	CC	Plunger (M32 x 93)	3
95	† 89835	SS	89835	SS	89835	SS	Stud, Retainer (M7 x 87)	3
96	20184	PTFE	20184	PTFE	20184	PTFE	Backup Ring, Plunger Retainer	3
97	14190	NBR	14190	NBR	14190	NBR	O-Ring, Plunger Retainer-70D	3
98	44069	SS	44069	SS	44069	SS	Gasket, Plunger Retainer	3
99	44068	SS	44068	SS	44068	SS	Retainer, Plunger (M7) (See Tech Bulletin 074)	3
100	49788	NY	49788	NY	49788	NY	Retainer, Low-Pressure, Front	3
	49789	NY	49789	NY	49789	NY	Retainer, Low-Pressure, Rear	3
101	110796	—	110796	—	110796	—	Wick, Long Tab (M32)	3
106	† 44098	NBR	† 44098	NBR	† 44098	NBR	Seal, Low-Pressure with SS-Spring	3
110	670134	NABC	48583	SS	45830	NAB	Manifold, Inlet	1
	—	—	49545	SS	—	—	Manifold, Inlet Flushed (1/4" Ports)	1
116	126570	STCPR	19085	S	19085	S	Lockwasher, Split	4
	19085	S	—	—	—	—	Lockwasher, Split (Model 2530E)	4
117	126518	STCPR	88398	S	88398	S	Screw, HSH (M12 x 40) (See Tech Bulletin 074)	4
	88398	S	—	—	—	—	Screw, HSH (M12 x 40) (Model 2530E) (See Tech Bulletin 074)	4
125	† 45832	SNG	45832	SNG	45832	SNG	Seal, High-Pressure with SS	3
143	14203	NBR	14203	NBR	14203	NBR	O-Ring, Adapter, Low-Pressure, Rear-70D	3
150	45752	BB	45835	SS	45835	SS	Adapter, Low-Pressure	3
154	18690	NBR	18690	NBR	18690	NBR	O-Ring, Adapter, Low-Pressure, Front-70D	3
155	14520	NBR	14520	NBR	14520	NBR	O-Ring, Adapter, Valve-70D	6
157	45751	BB	45834	SS	45834	SS	Adapter, Valve	3
164	† 46857	SS	46857	SS	46857	SS	Seat (See Tech Bulletin 076)	6
165	14014	NBR	14014	NBR	14014	NBR	O-Ring, Seat	6
166	† 45839	SS	45839	SS	45839	SS	Valve	6
167	† 45840	SS	45840	SS	45840	SS	Spring	6
168	110682	PVDF	110682	PVDF	110682	PVDF	Retainer, Spring	6
185	670135	NABC	48585	SS	45836	NAB	Manifold, Discharge	1
186	126570	STCPR	19085	S	19085	S	Lockwasher, Split	8
	19085	S	—	—	—	—	Lockwasher, Split (Model 2530E)	8
188	126517	STCPR	89628	S	89628	S	Screw, HSH (M12 x 65) (See Tech Bulletin 074)	8
	89628	S	—	—	—	—	Screw, HSH (M12 x 65) (Model 2530E) (See Tech Bulletin 074)	8

Bold print part numbers are unique to a particular pump model.

Italics are optional items. † Production parts are different than repair parts. R Components comply with RoHS Directive.

For additional technical information see www.catpumps.com/literature/tech-bulletins. MATERIAL CODES (Not Part of Part Number):

ABS=ABS Plastic ALE=Aluminum Epoxy BB=Brass CC=Ceramic CM=Chrome-moly EPDM=Ethylene Propylene Diene Monomer F=Cast Iron
FCM=Forged Chrome-moly FFKM=Perfluoroelastomer FPM=Fluorocarbon HT=High Temp (EPDM Alternative) NAB=Nickel Aluminum Bronze
NABC=Nickel Aluminum Bronze Chrome Plated NBR=Medium Nitrile (Buna-N) NY=Nylon PC=Poly Carbonate PE=Polyethylene POP=Polypropylene
PTFE=Pure Polytetrafluoroethylene PVDF=Polyvinylidene Fluoride RBR=Rubber S=304SS SS=316SS SNG=Special Blend (Buna) ST2=Special PTFE2
STL=Steel SSHS=316SS/High Strength STCP=Steel/Chrome Plated STHT=Special PTFE High Temp STZP=Steel/Zinc Plated TNM=Special High Strength

Optional Parts and Accessories and Service Parts listed on page 3. Standard and optional Seal and Valve Kits listed on page 4.

EXPLODED VIEW

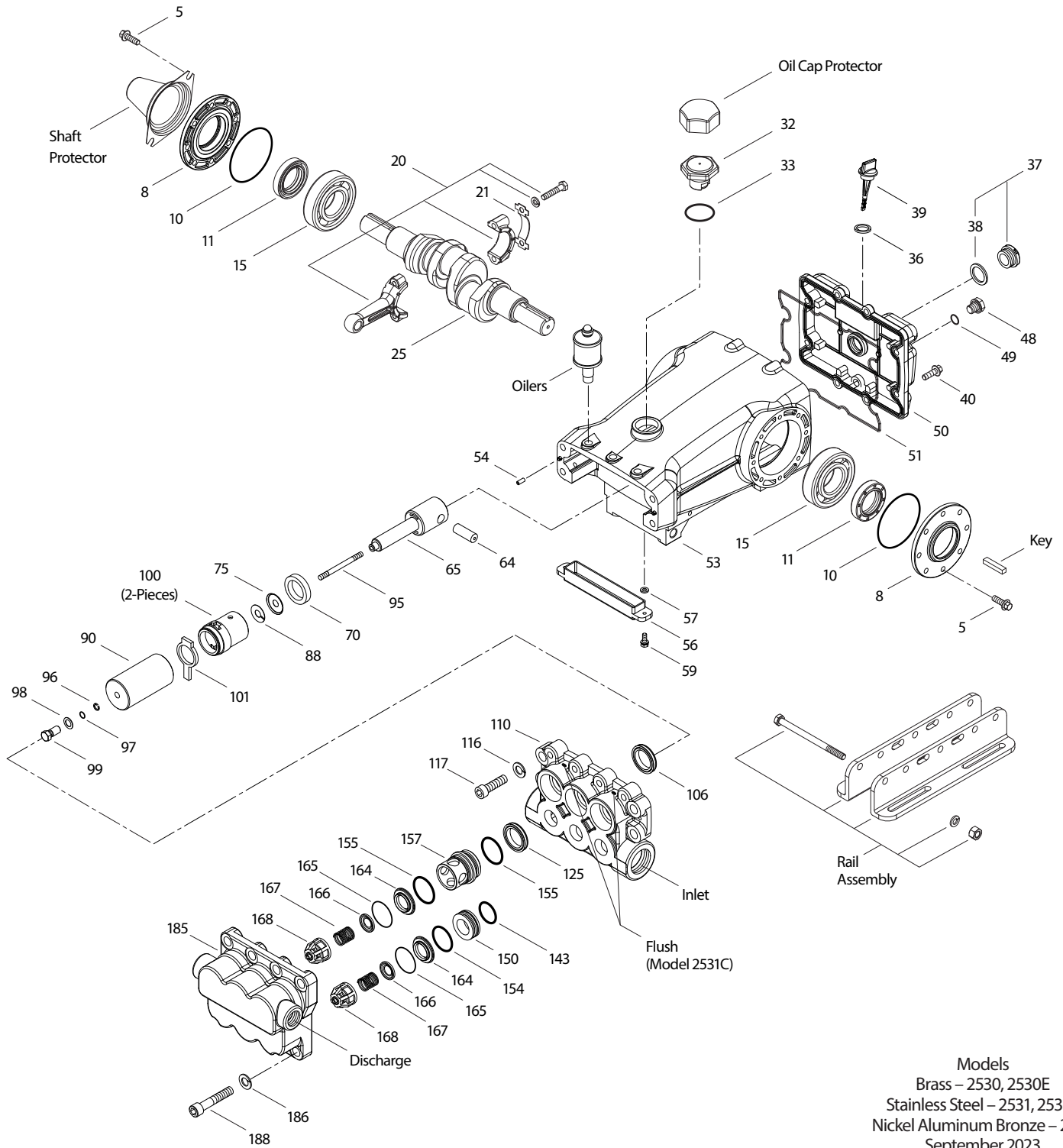

Models
 Brass – 2530, 2530E
 Stainless Steel – 2531, 2531C
 Nickel Aluminum Bronze – 2537
 September 2023

OPTIONAL PARTS AND ACCESSORIES

PART	DESCRIPTION	QTY
990036	Key (M8 x 7 x 40)	1
30614	Assembly, Rail	1
26516	Protector, Shaft	1
828710	Protector, Oil Cap with Gasket	1
30278	Oiler (1 oz)	3
34334	Kit, Oil Drain (3/8" x 24") (Not Shown)	1
30696	Reverse Pliers (Not Shown)	1

SERVICE PARTS

PART	DESCRIPTION	QTY
30952	Seal Kit – Standard NBR	1
33952	Valve Kit – Standard NBR	2
6107	Oil, Bottle (21 oz bottle) (Fill to Specified Crankcase Capacity Prior to Start-up)	4
6139	Lubricant, Anti-Seize (8 oz) (See Tech Bulletin 095) (Model 2530E)	1
6124	Gasket, Liquid (3 oz)	1
701931	Sealant, Silicone (3 oz) (2530E) (See Tech Bulletin 100)	1
814838	Head, Complete – with NBR Seals and O-Rings (Model 2530)	1
816735	Head, Complete – with NBR Seals and O-Rings (Model 2531)	1
816538	Head, Complete – with NBR Seals and O-Rings (Model 2537)	1

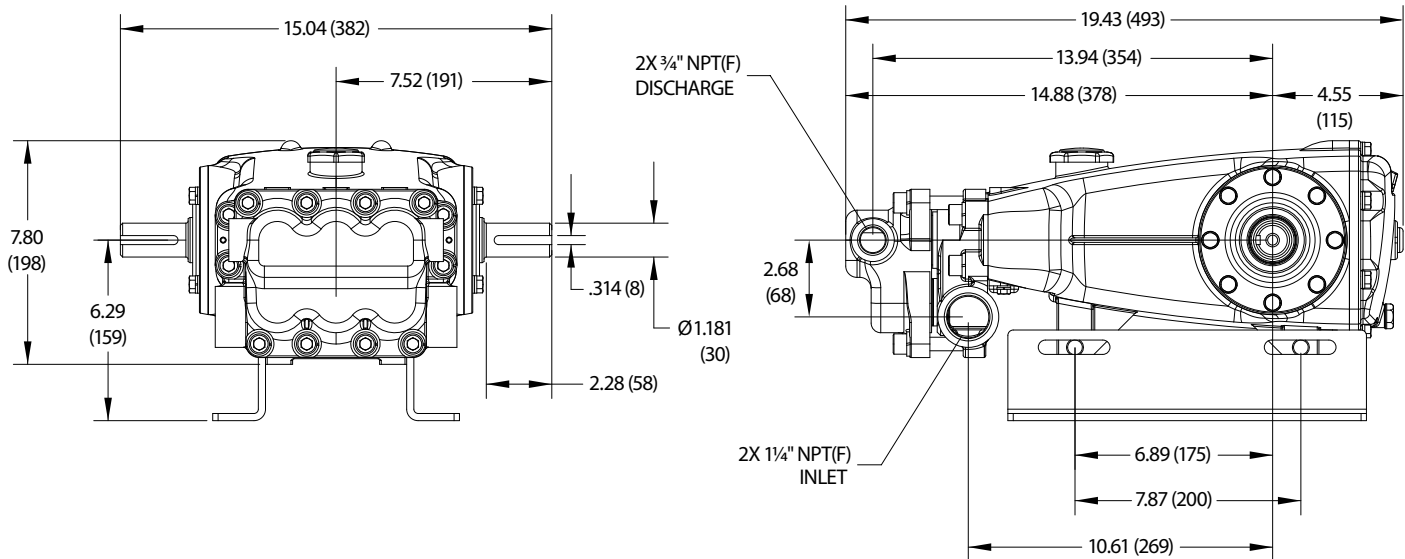

Models 2530, 2530E, 2531, 2537

SEAL KITS One (1) seal kit required per pump

PUMP MODELS	NBR (STD)	FPM (.0110)	EPDM (.0220) ◆	FFKM (.0770)	STHT (.3400)
2530, 2530E, 2531, 2531C, 2537	30952	33607	33608	31257*	76292

ITEM (Included in Seal Kits)						DESCRIPTION	QTY
97	14190	14161	48239	703586	14190	O-Ring, Plunger Retainer	3
106	44098	44827	48244	76298	76298	Seal, Low-Pressure with SS-Spring	3
125	45832	48220	48220	48220	48220	Seal, High-Pressure with SS	3
143	14203	11731	48241	701851	14203	O-Ring, Adapter, Low-Pressure Rear	3
154	18690	11744	48242	701851	18690	O-Ring, Adapter, Low-Pressure Front	3
155	14520	11745	48240	702962	14520	O-Ring, Adapter, Valve	6

◆ Silicone oil/grease required *Review material codes for individual items (STG generally may be used as an alternative)

VALVE KITS Two (2) valve kits required per pump

PUMP MODELS	NBR (STD)	FPM (.0110)	EPDM (.0220) ◆	FFKM (.0770)	STHT (.3400)
2530, 2530E, 2531, 2531C, 2537	33952	31267	31268	76267	33952

ITEM (Included in Valve Kits)						DESCRIPTION	QTY
143	14203	11731	48241	701851	14203	O-Ring, Adapter, Low-Pressure Rear	3
154	18690	11744	48242	703588	18690	O-Ring, Adapter, Low-Pressure Front	3
155	14520	11745	48240	702962	14520	O-Ring, Adapter, Valve	6
164	46857	46857	46857	46857	46857	Seat	3
165	14014	48238	48243	703587	14014	O-Ring, Seat	3
166	45839	45839	45839	45839	45839	Valve	3
167	45840	45840	45840	45840	45840	Spring	3
168	110682	110682	110682	110682	110682	Retainer, Spring	3

◆ Silicone oil/grease required

⚠ CAUTIONS AND WARNINGS

All high-pressure systems require a primary pressure regulating device (e.g. regulator, unloader) and a secondary pressure relief device (e.g. pop-off valve, relief valve). Failure to install such relief devices could result in personal injury or damage to pump or property. Cat Pumps does not assume any liability or responsibility for the operation of a customer's high-pressure system. Read all CAUTIONS and WARNINGS before commencing service or operation of any high-pressure system. The CAUTIONS and WARNINGS are included in each Service Manual and with each Accessory Data sheet. CAUTIONS and WARNINGS can also be viewed online at www.catpumps.com/dynamic-literature/cautions-and-warnings or can be requested directly from Cat Pumps.

WARRANTY

View the Limited Warranty online at www.catpumps.com/literature/cat-pumps-limited-warranty