

SERVICE MANUAL

1CX SERIES PLUNGER PUMP



| PUMP MODEL | FLOW | | PRESSURE | | RPM Pump | TEMPERATURE | | SHAFT DIA. | | OIL CAPACITY | |
|------------|------|-------|----------|-----|----------|-------------|----|------------|------|--------------|------|
| | gpm | lpm | psi | bar | | °F | °C | in | mm | oz | l |
| 1CX013R | 0.13 | 0.492 | 1250 | 86 | 1750 | 140 | 60 | .500 | 12.7 | 2.03 | 0.06 |
| 1CX025R | 0.25 | 0.946 | 1250 | 86 | 1750 | 140 | 60 | .500 | 12.7 | 2.03 | 0.06 |
| 1CX050R | 0.50 | 1.892 | 1250 | 86 | 1750 | 140 | 60 | .500 | 12.7 | 2.03 | 0.06 |

IMPORTANT SAFETY INSTRUCTIONS

It is the responsibility of the user to read and understand all instructions, important safeguards, and safety precautions before operating or servicing any pump. Failure to do so may result in property damage, personal injury or death.

General Safety Information and Symbols

Pay special attention to the following signal words, safety alert symbols and statements:

⚠ DANGER indicates a hazardous situation which, if not avoided, will result in death or serious injury.

⚠ WARNING indicates a hazardous situation which, if not avoided, could result in death or serious injury.

⚠ CAUTION indicates a hazardous situation which, if not avoided, could result in minor or moderate injury or property damage.

NOTICE indicates a hazardous situation which, if not avoided, could result in property damage.

⚠ Indicates a potential personal injury hazard. Obey all safety messages that follow this symbol to avoid possible injury or death.

SERVICING THE 1CX SERIES PLUNGER PUMP

⚠ WARNING

Do not service pump or electrical equipment while energized.
Electricity can cause property damage, personal injury or death.

1. Adhere to "Lock Out" and "Tag Out" procedures for electrical equipment.
2. Before commencing pump service, turn power supply off.
3. Keep water away from electrical outlets and electrical devices.
4. Electrical components must be installed by a qualified electrician to avoid risk of electrocution.

SERVICING THE VALVES

Disassembly

NOTE: All pump models require one (1) stacked valve kit to repair pump. Discharge and inlet valve assemblies may stay together or separate during removal.

1. Disconnect discharge and by-pass lines from pressure regulator.
2. Using a M22 wrench, loosen hex valve plug and remove pressure regulator from manifold head.

NOTE: There is no need to separate pressure regulator from hex valve plug.

3. Use reverse pliers to remove stacked valve assembly from the valve chamber.
4. If the discharge valve assembly separates from the inlet valve assembly, use reverse pliers to remove it from the valve chamber.

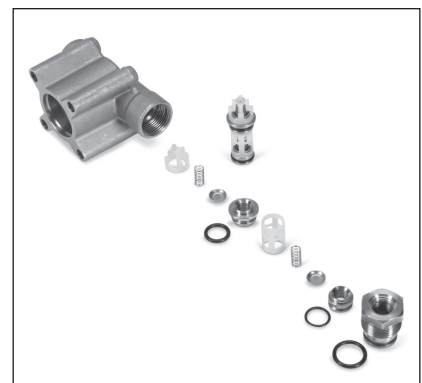

NOTICE

Exercise caution as the reverse pliers may damage the threads in valve chamber or spring retainer.

5. If the inlet spring retainer separates from the inlet seat, remove the spring and valve from the valve chamber. Thread an M8 screw into the inlet seat and remove from valve chamber.
6. To separate valve assemblies use the same M8 screw and thread into bottom of seat until screw contacts bottom of valve. Continue threading in screw until spring retainer separates from seat.
7. Remove o-rings from both seats and valve plug.

Reassembly

NOTE: Reassembly can done by either using the pre-assembled stacked valve assembly (see step 1) or can be done on a piece part basis (see step 2).

NOTE: Inlet valve seat, valve seat o-ring and inlet spring retainer are different than discharge valve seat, valve seat o-ring and discharge spring retainer.

1. Lubricate and install new o-ring onto outside diameter of discharge seat.
2. Place discharge seat on work surface with small diameter side down.
3. Place valve onto seat with concave side up, then position spring on valve.
4. Install short spring retainer with deep stepped end over spring and snap onto seat.
5. Lubricate and install new o-ring onto outside diameter of small inlet seat.
6. Place inlet seat on work surface with o-ring side down.
7. Place valve onto seat with concave side up, then position spring on valve.
8. Install tall spring retainer with deep stepped end over spring and snap onto seat.
9. Snap discharge valve assembly onto inlet valve assembly and then press entire assembly into valve chamber until completely seated.
10. Lubricate and install new o-ring onto hex valve plug.
11. Thread in hex valve plug with pressure regulator by hand.
Torque to 310 in-lbs, 25.8 ft-lbs, 35 N-m.

SERVICING THE SEAL

Disassembly

NOTE: All pump models require one (1) seal kit to repair pump.

1. Use a M5 allen wrench to remove the four (4) hex socket head (HSH) screws from the manifold head.
2. Support the manifold head from the underside and pull the manifold head away from the crankcase.

NOTICE

Keep the manifold head properly aligned with the ceramic plunger when removing to avoid damage to the plunger.

3. Place manifold head on work surface with crankcase side up.
4. Remove seal retainer from plunger rod.
5. Use a screwdriver to pry out the low-pressure seal from seal case.



NOTICE

Screwdriver may damage seal during removal.

6. Insert a reverse pliers into the second lip of the seal case and pull seal case from seal chamber.

NOTE: Do not insert reverse pliers into the first lip of the seal case because this may damage the sealing surface area for the low-pressure seal.

7. Carefully insert a small screwdriver under the o-ring and roll the o-ring off seal case.

NOTICE

Exercise caution as the screwdriver may score o-ring sealing surface.

8. Remove high-pressure seal either by hand or with a reverse pliers from seal chamber.

Reassembly

1. Examine manifold chamber walls for scale build-up or damage.
2. Examine high-pressure seal for frayed edges or uneven wear and replace as needed.
3. Examine seal case o-ring for cuts or deterioration and replace as needed.
4. Examine low-pressure seal for wear to the internal ridges, outer surfaces for broken springs and replace as needed.
5. Examine seal retainer for deformation and replace as needed.
6. Lubricate and press new high-pressure seal into seal chamber with grooved side down.
7. Press new low-pressure seal into seal case with the garter spring down.
8. Examine ceramic plunger for cracks or scale build-up and proceed to **SERVICING THE PLUNGER** if worn.
9. Slide seal retainer over ceramic plunger with the drain slots facing the crankcase and the openings to the top and bottom. Press into the crankcase.
10. Lightly lubricate ceramic plunger, then carefully slide the manifold head over the ceramic plunger, supporting it from the underside to avoid damage to the plunger or seal. Press the manifold head until flush with crankcase.
11. Thread HSH screws in hand tight. Torque to 62 in-lbs, 5.2 ft lbs, 7 N-m in sequence as shown below

TORQUE SEQUENCE

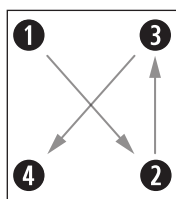

SERVICING THE PLUNGER

Disassembly

1. To service the ceramic plunger, it is necessary to remove the manifold head. See **SERVICING THE SEAL**, disassembly, steps 1 – 4.
2. Use a M10 hex tool to loosen the plunger retainer on plunger rod and remove.
3. Remove the ceramic plunger and seal washer from plunger retainer.

Reassembly

1. Visually inspect the crankcase oil seal for deterioration or leaks. Contact Cat Pumps for assistance with replacement. See **SERVICING THE CRANKCASE**.
2. Examine seal washer and replace if cut or worn.
3. Examine plunger retainer for damaged threads and replace as needed.
4. Install new seal washer onto plunger retainer.
5. Examine the ceramic plunger for scoring, scale buildup, chips or cracks and replace as needed. The ceramic plunger does not need to be replaced with every seal servicing.
6. Slide plunger retainer with seal washer into flat end of ceramic plunger.
7. Apply Loctite® 242® to exposed threaded end of plunger retainer.
8. Install ceramic plunger with plunger retainer and seal washer over plunger rod shoulder and thread hand tight. Torque to 55 in-lbs, 4.6 ft-lbs, 6.2 N-m.

NOTE: Ceramic plunger can only be installed in one direction. Counter bore end of ceramic plunger fits over plunger rod shoulder.

9. To reinstall manifold head with seal follow **SERVICING THE SEAL, Reassembly**, steps 8 – 12.

SERVICING THE CRANKCASE

1. While manifold head, plunger and retainer are removed, examine crankcase oil seal for leaking and wear.
2. Check for any signs of leaking at bearing cover, drain plug or bubble gauge.
3. Check oil level and for evidence of water in oil. Change crankcase oil on a regular schedule. See **PREVENTATIVE MAINTENANCE CHECK-LIST**.
4. Examine crankshaft oil seal externally for drying, cracking or leaking.
5. Contact Cat Pumps or local distributor if crankcase service is required.



SERVICING THE REGULATOR

NOTE: All pump models require one (1) o-ring kit to repair regulator.

Disassembly

1. Disconnect discharge and by-pass lines from regulator.
2. Using a M22 wrench, loosen hex valve plug and remove pressure regulator from manifold head.

NOTE: There is no need to separate pressure regulator from hex valve plug.

3. Use a M6 allen wrench to remove adjusting cap by turning in a counter clockwise direction.
4. Remove exposed coil spring and then flat spring retainer.
5. Use a needle nose pliers to remove piston stem with o-ring.
6. Remove seat with o-ring at bottom of regulator.

Reassembly

1. Examine seat for pitting or wear and replace as needed.
Examine o-ring for cuts or wear and replace as needed.
2. Lubricate and install o-ring onto seat.
3. Press new seat with o-ring into regulator chamber with small diameter down until squarely seated.
4. Examine piston stem for grooves, pitting or wear and replace as needed.
Examine o-ring for cuts or wear and replace as needed.
5. Lubricate and install o-ring onto piston stem.
6. Lower piston stem into regulator chamber with tapered surface facing down.
7. Examine flat spring retainer and coil spring for fatigue or breaks and replace as needed.
8. Place flat spring retainer onto top of piston stem, then coil spring.
9. Thread in adjusting cap by turning in a clockwise direction.
10. Reconnect by-pass and discharge lines to regulator.

Loctite and 242 are registered trademarks of Henkel Corporation.

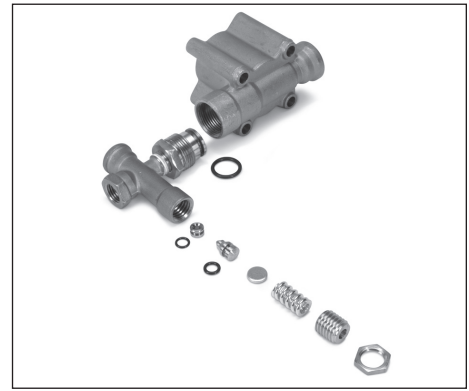

REMOVING PUMP FROM MOTOR

NOTE: DO NOT remove three (3) HSH screws (M6 x 14) that fasten pump crankcase to bearing cover. Leakage of crankcase oil will result.

1. Remove four (4) HSH screws (M6 x 16) that mount the bearing cover to the motor.
2. Remove pump/bearing cover from motor.

NOTE: If pump does not separate from motor then continue with steps 3 – 5.

3. Ensure all four (4) HSH screws (M6 x 16) are removed completely.
4. Rotate pump by hand so that the threaded holes on the bearing cover are at positions 12 o' clock and 6 o' clock.
5. Using two (2) M8 screws, thread both screws in at the same time so they make contact with motor face. Continue turning in both screws until bond is broken and pump can be removed, then remove screws.

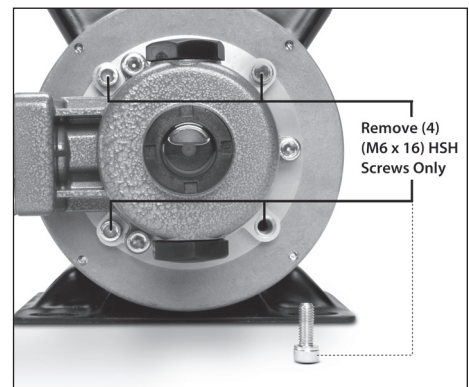

INSTALLATION OF REPLACEMENT PUMP TO MOTOR

NOTE: All pump models are shipped with Cat Pumps premium custom-blend ISO 68 hydraulic oil.

NOTE: All pumps models come with one (1) bolt kit.

NOTE: DO NOT remove three (3) HSH screws (M6 x 14) that fasten pump crankcase to bearing cover. Leakage of crankcase oil will result.

1. Rotate motor shaft by hand so that keyway is facing up.
2. Insert key into keyway of motor.
3. Lubricate motor shaft with anti-seize lubricant supplied in bolt kit.
4. Slide hollow shaft of pump over motor shaft keeping key and keyways aligned.
5. Align four (4) holes of bearing cover with motor holes and thread in by hand four (4) HSH screws. Torque to 62 in-lbs, 5.2 ft-lbs, 7 N-m as shown in **TORQUE SEQUENCE**.

NOTE: Ensure lip surface of bearing cover fits squarely on motor surface.

6. Reconnect discharge and by-pass lines to pressure regulator.

PREVENTIVE MAINTENANCE CHECK-LIST

| Check | Daily | Weekly | 50 hrs. | 500 hrs. * | 1,000 hrs. ** |
|--------------------|-------|--------|---------|------------|---------------|
| Clean Filters | • | | | | |
| Oil Level/Quality | • | | | | |
| Oil Leaks | • | | | | |
| Water Leaks | • | | | | |
| Plumbing | | • | | | |
| Initial Oil Change | | | • | | |
| Oil Change | | | | • | |
| Seal Change | | | | | • |
| Valve Change | | | | | • |
| Accessories | | | | | • |

* If other than Cat Pumps special custom blend, ISO 68 hydraulic oil is used, change cycle should be every 300 hours.

** Each system's maintenance cycle will be exclusive. If system performance decreases, check immediately. If no wear at 1000 hours, check again at 1500 hours and each 500 hours until wear is observed. Valves typically require changing every other seal change.

Duty cycle, temperature, quality of pumped liquid and inlet feed conditions all affect the life of pump wear parts and service cycle.

** Remember to service the regulator at each seal servicing and check all system accessories and connections before resuming operation.

GENERAL SAFETY INFORMATION AND SYMBOLS

⚠ DANGER

A. FLAMMABLE OR EXPLOSIVE LIQUID HAZARD

Do not operate pump with flammable or explosive liquids unless extraordinary safety precautions are observed. Leaks of flammable or explosive liquids, if exposed to elevated temperatures, static electricity, sparks or other hazards, will result in flame or possible explosion, causing serious personal injury, death or property damage.

1. Before operating pump with flammable or explosive liquids, ensure proper maintenance has been performed.
2. Do not operate pump with flammable or explosive liquids if leaks are detected.
3. Only pump flammable or explosive liquids that are compatible with pump component materials.
4. Do not operate pump with flammable or explosive liquids without safeguards or safety systems to detect leaks, elevated temperatures, spark prevention or any other hazards defined by the NFPA systems.
5. Do not remove Flammable Liquids Product Suitability Hang Tag to assure proper safety.
6. Follow ATEX guidelines for potentially explosive atmospheres.

⚠ WARNING

A. ELECTRICAL SHOCK HAZARD

Do not service pump or electrical equipment while energized. Electricity can cause personal injury, death or property damage.

1. Adhere to "Lock Out" and "Tag Out" procedures for electrical equipment.
2. Before commencing pump service, turn power supply off.
3. Keep water away from electrical outlets and electrical devices.
4. Electrical components must be installed by a qualified electrician to avoid risk of electrocution.

B. ROTATING PARTS HAZARD

Do not service pump while energized. Moving, rotating or reciprocating parts can crush and cut, causing personal injury, death or property damage.

1. Adhere to "Lock Out" and "Tag Out" procedures for electrical equipment.
2. Before commencing pump service, turn power supply off, turn water supply off, squeeze trigger on gun to relieve system pressure.
3. For mobile equipment, be sure engines and hydraulics are turned off and secured to avoid accidental start.
4. Do not operate with safety guards removed.
5. Always use safety guards on all belt drives, couplings and shafts.

C. HOT SURFACE HAZARD

Do not touch pump, accessories or drive system while operating, and until cool down is complete. Touching hot surface areas of the pump, accessories or drive system can cause severe burns or personal injury.

D. SKIN PUNCTURE HAZARD

Do not allow spray to contact any part of the body or animals. Pumped liquids under high-pressure can pierce skin and underlying tissue or can deflect debris leading to serious personal injury or death.

1. Relieve all line pressure in the inlet line to the pump and discharge line from the pump before performing any maintenance on the pump.
2. When a high-pressure gun is not in use, set safety trigger lock (safety latch) to avoid accidental high-pressure operation and personal injury or property damage.
3. Do not check for leaks with hand. Use a piece of cardboard to check for leaks.
4. Review cleaning procedures to minimize heavy back blasting.
5. Wear adequate safety equipment and clothing when operating high-pressure sprayer. Never use high-pressure spray with bare feet or exposed skin, and always wear safety glasses.

E. PUMPING LIQUIDS HAZARD

Do not operate pump with hot water, chemicals, or other hazardous liquids unless extraordinary safety precautions are observed. Pumping hot water, chemicals, or other hazardous liquids can expose personnel to serious injury.

1. Provide guards or shields around equipment to protect personnel.
2. Wear mask, goggles or eye protection while operating high-pressure equipment.
3. Obtain a safety data sheet (SDS) and take appropriate safety measures for the liquid being handled.

F. OVER PRESSURIZATION HAZARD

Do not operate high-pressure pumping system unless extraordinary safety precautions are observed. A high pressure pumping system can deadhead or overpressurize causing serious personal injury and property damage.

1. All high-pressure systems require a primary pressure regulating device (i.e., regulator or unloader) and a secondary pressure safety relief device (i.e., pop-off valve, safety valve, rupture disc) to assure proper pressure setting and overpressure protection.
2. All high-pressure systems require a pressure gauge to monitor pressure settings and avoid overpressure of equipment or personal harm.
3. Install a primary pressure relief device on the discharge side of the pump.
4. Install a secondary pressure relief device between the primary device and pump.
5. Install a pressure gauge onto the discharge manifold or in the discharge line near the manifold.
6. Open all valves on discharge side of plumbing before operation.

G. OXYGEN HAZARD

Do not charge Pulsation Dampeners with oxygen. Oxygen may cause an explosion causing personal injury, death or property damage.

1. Use nitrogen only when charging pulsation dampeners. DO NOT USE OXYGEN.
2. Use proper charging tools to charge pulsation dampeners.
3. Charge pulsation dampener within specifications stated on data sheet to assure proper pulsation dampening and prevent failure of bladder.

H. FALL HAZARD

Do not operate pressure washer while standing on slippery or unstable surface unless extraordinary safety precautions are observed. Pressure washing may create slippery surface on which a person may slip and fall causing personal injury or death.

1. Wear suitable footwear to maintain a good grip on wet surfaces.
2. Do not stand on ladders or scaffolding.
3. Do not over reach or stand on unstable supports.
4. Keep good footing and balance and hold gun with both hands to control kick back.

CAUTION

A. IMPROPER USE OF FITTINGS HAZARD

Do not operate the pump with improperly connected, sized, worn or loose fittings, pipes or hoses. Operating the pump under these conditions could result in personal injury and property damage.

1. Ensure all fittings, pipes and hoses are properly rated for the maximum pressure rating and flow of the pump.
2. Check all fittings and pipes for cracks or damaged threads.
3. Check all hoses for cuts, wear, leaks, kinks or collapse before each use.
4. Ensure all connections are tight and secure.
5. Use PTFE thread tape or pipe thread sealant (sparingly) to reconnect plumbing. Do not wrap tape beyond the last thread, this will prevent tape from becoming lodged in the pump or accessories.
6. Apply proper sealants to assure secure fit or easy disassembly when servicing.

B. FROZEN LIQUID HAZARD

Do not operate the pump with frozen liquid. Operating the pump under this condition could over pressurize and jettison the manifold from the crankcase causing personal injury and property damage.

1. Store pump or pumping system in an environmentally controlled room protected from freezing temperatures.
2. Follow procedures in TECH BULLETIN 083 to winterize pump.

C. CLEANING PUMP HAZARD

Do not use solvents that are flammable and toxic to clean or degrease equipment. Use of these solvents could result in personal injury and property damage.

1. Follow safety instructions as found in SDS or on packaging of each liquid.
2. Clean equipment in a well ventilated area.
3. Disposal of solvents to be in accordance with local, state and federal regulations.

D. OPERATING BEYOND SPECIFICATIONS HAZARD

Do not operate the pump outside the specifications of individual pump Data Sheet or Service Manual. Operating the pump under these conditions could result in personal injury and property damage.

1. Do not operate the pump faster than the maximum recommended RPM.
2. Do not operate the pump at pressures higher than the maximum recommended pressure.
3. Do not operate the pump at temperatures higher than the maximum recommended temperatures.
4. Do not use accessories that are not compatible or rated for the pump.

E. LIFTING DEVICE HAZARD

Do not lift pump with unsuitable lifting devices. Use of unsuitable lifting devices may cause pump to fall resulting in personal injury, damage to pump and/or pump with drive/base plate.

1. Lifting eyes installed on the pump must be used only to lift the pump.
2. Special lifting eyes should be installed on the base for lifting the pumping system (i.e. base, drive and accessories)
3. If slings or chains are used for lifting, they must be safely and securely attached to properly balance the weight of the unit.
4. Inspect slings and chains prior to use and replace worn and damaged slings and chains.

NOTICE

A. OIL HAZARD

Use only genuine Cat Pumps custom-blend, premium grade, petroleum-based hydraulic oil. Use of other oil may not provide proper lubrication of drive-end components and may result in damage to the crankcase of the pump.

1. Cat Pumps custom-blend oil is available worldwide in 21 oz. bottles, cases, or 5-gallon twin packs. Use of other oils may void the warranty.
2. Fill pump crankcase to specific capacity indicated on data sheet or service manual prior to startup.

B. ROTATION OF PUMP HAZARD

Do not rotate pump crankshaft in reverse direction. Rotation of pump crankshaft in reverse direction may not provide proper lubrication and may result in damage to the drive-end components.

1. Forward rotation is the top of the crankshaft turning towards the manifold head of the pump.
2. Ensure oil is filled to the center red dot on sight gauge for forward rotation.
3. Ensure oil is filled to slightly above center red dot on sight gauge for reverse rotation.

C. BELT TENSION HAZARD

Do not operate pump with excessive belt tension. Excessive belt tension may damage the pumps bearings or reduce horsepower.

1. Rotate pump crankshaft before starting to ensure shaft and bearings are moving freely.
2. Ensure pulleys are properly sized.
3. Periodically replace belts to assure full horsepower transmission.
4. Ensure center distance dimensions between pulleys is correct.

D. BY-PASS OPERATION HAZARD

Do not operate the pump in by-pass for extended lengths of time. Operating the pump under this condition can quickly cause heat build-up resulting in damage to the pump.

1. Route by-pass line to supply reservoir to dissipate heated by-pass liquid into a large reservoir of cool water to reduce excessive temperature build-up.
2. Route by-pass line to inlet of pump using a thermo valve in the by-pass line or auto shut-off assembly that will sense temperature rise and either by-pass or shut down system before damage occurs.

E. DRY OPERATION HAZARD

Do not operate the pump without water or liquid. Operating pump under these conditions could result in damage to the pump.

1. Open all valves on inlet side of pump before starting operation to prevent starving the pump.
2. Do not exceed inlet suction pressure limit specified in pump Data Sheet.
3. Ensure inlet feed exceeds the maximum flow being delivered by the pump.
4. Ensure all fittings, pipes and hoses are properly sized for the pump to avoid restricted flow.
5. Review and implement all other recommendations appropriate for your system from the Inlet Condition Check-List.

DIAGNOSIS AND MAINTENANCE

One of the most important steps in a high-pressure system is to establish a regular maintenance program. This will vary slightly with each system and is determined by various elements such as the duty cycle, the liquid being pumped, the actual specifications vs. rated specifications of the pump, the ambient conditions, the inlet conditions and the accessories in the system. A careful review of the necessary inlet conditions and protection devices required before the system is installed will eliminate many potential problems. Cat Pumps are very easy pumps to service and require far less frequent service than most pumps. Typically, only common tools are required, making in-field service convenient, however, there are a few custom tools, special to certain models, that do simplify the process. This service manual is designed to assist you with the disassembly and reassembly of your pump. The following guide will assist in determining the cause and remedy to various operating conditions. You can also review our **FAQ** or **SERVICE** sections on our **WEB SITE** for more facts or contact Cat Pumps directly.

| PROBLEM | PROBABLE CAUSE | SOLUTION |
|----------------------------------|--|--|
| Low pressure | <ul style="list-style-type: none"> • Worn nozzle. • Air leak in inlet plumbing. • Pressure gauge inoperative or not registering accurately. • Relief valve stuck, partially plugged or improperly adjusted. • Inlet suction strainer (filter) clogged or improperly sized. • Abrasives in pumped liquid. • Leaky discharge hose. • Inadequate liquid supply. • Severe cavitation. • Worn seals. • Worn or dirty inlet/discharge valves. | <ul style="list-style-type: none"> • Replace with proper size nozzle. • Tighten fittings and hoses. Use PTFE liquid or tape. • Check with new gauge. Replace worn or damaged gauge. • Clean/adjust relief valve. Replace worn seats/valves and o-rings. • Clean filter. Use adequate size filter. Check more frequently. • Install proper filter. • Replace discharge hose with proper rating for system. • Pressurize inlet. • Check inlet conditions. • Install new seal kit. Increase frequency of service. • Clean inlet/discharge valves or install new valve kit. |
| Pulsation | <ul style="list-style-type: none"> • Foreign material trapped in inlet/discharge valves. | <ul style="list-style-type: none"> • Clean inlet/discharge valves or install new valve kit. |
| Water leak | <ul style="list-style-type: none"> • Under the manifold • Into the crankcase | <ul style="list-style-type: none"> • Worn high-pressure or low-pressure seals. • Humid air condensing into water inside the crankcase. • Excessive wear to high-pressure or low-pressure seals. • Install new seal kit. Increase frequency of service. • Install new oil cap protector. Change oil every 3 months or 500 hours. • Install new seal kit. Increase frequency of service. |
| Knocking noise | <ul style="list-style-type: none"> • Inlet supply • Bearing | <ul style="list-style-type: none"> • Inadequate inlet liquid supply. • Broken or worn bearing. • Check liquid supply. Increase line size or pressurize. • Replace bearing. |
| Oil leak | <ul style="list-style-type: none"> • Crankcase oil seal • Crankshaft oil seal and o-ring • Drain plug • Bubble gauge • Bearing cover • Filler cap | <ul style="list-style-type: none"> • Worn crankcase oil seal. • Worn crankshaft oil seal or o-ring on bearing cover. • Loose drain plug or worn drain plug o-ring. • Loose bubble gauge or worn bubble gauge gasket. • Loose bearing cover or worn bearing cover o-ring. • Loose filler cap or excessive oil in crankcase. • Replace crankcase oil seal. • Remove bearing cover and replace o-ring and/or oil seal. • Tighten drain plug or replace o-ring. • Tighten bubble gauge or replace gasket. • Tighten bearing cover or replace o-ring. • Tighten filler cap. Fill crankcase to specified capacity. |
| Pump runs extremely rough | <ul style="list-style-type: none"> • Inlet conditions • Pump valves • Pump seals | <ul style="list-style-type: none"> • Restricted inlet or air entering the inlet plumbing • Stuck inlet/discharge valves. • Leaking high-pressure or low-pressure seals. • Correct inlet size plumbing. Check for air tight seal. • Clean out foreign material or install new valve kit. • Install new seal kit. Increase frequency of service. |
| Premature seal failure | <ul style="list-style-type: none"> • Scored plunger. • Over pressure to inlet manifold. • Abrasive material in the liquid being pumped. • Excessive pressure and/or temperature of pumped liquid. • Running pump dry. • Starving pump of adequate liquid. • Eroded manifold. | <ul style="list-style-type: none"> • Replace plunger. • Reduce inlet pressure per specifications. • Install proper filtration at pump inlet and clean regularly. • Check pressure and inlet liquid temperature. • DO NOT RUN PUMP WITHOUT LIQUID. • Increase hose one size larger than inlet port size or pressurize. • Replace manifold. Check liquid compatibility. |

⚠ CAUTIONS AND WARNINGS

All High-Pressure Systems require a primary pressure regulating device (i.e. regulator, unloader) and a secondary pressure relief device (i.e. pop-off valve, relief valve). Failure to install such relief devices could result in personal injury or damage to pump or property. Cat Pumps does not assume any liability or responsibility for the operation of a customer's high-pressure system. Read all CAUTIONS and WARNINGS before commencing service or operation of any high-pressure system. The CAUTIONS and WARNINGS are included in each Service Manual and with each Accessory Data sheet. CAUTIONS and WARNINGS can also be viewed online at www.catpumps.com/dynamic-literature/cautions-and-warnings or can be requested directly from Cat Pumps.

WARRANTY

View the Limited Warranty on-line at www.catpumps.com/literature/cat-pumps-limited-warranty