

# DATA SHEET

## DIRECT DRIVE PLUNGER PUMPS



### Brass Models: **4DX10ER, 4DX15ER, 4DX20ER, 4DX27ER, 4DX30ER**

See page 8 for complete pump model number selection.

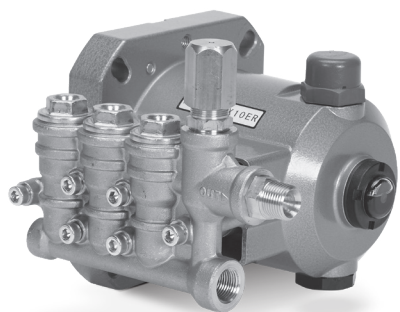

Model 4DX10ER Shown

#### FEATURES

- Fits standard 56C face electric motors.
- Stacked stainless steel valve design promotes long-life and easy servicing.
- Integral pressure regulator or unloader with built-in bypass ensures system pressure control and pump protection.
- Pump comes standard with NBR seals. Alternative seal materials are available for higher temperature or chemical compatibility.
- Includes crankcase oil.

#### COMMON

SPECIFICATIONS	U.S.	Metric
Maximum Discharge Pressure	2000 psi	138 bar
Inlet Pressure Range	Flooded to 60 psi	Flooded to 4.1 bar
Bore	0.630"	16 mm
Maximum Liquid Temp. (NBR)	140° F	60° C
<b>Alternate Seals Available for Higher Temperatures up to 180° F</b>		
Crankcase Capacity	8.5 oz	0.25 l
Inlet Port	3/8" NPT(F)	3/8" NPT(F)
Accessory Port	1/4" NPT(F)	1/4" NPT(F)
Discharge Ports	3/8" NPT(M)	3/8" NPT(M)
Shaft Diameter (Hollow)	5/8"	15.8 mm
Weight	10.7 lbs	4.9 kg
Dimensions (ER versions)	7.17 x 7.72 x 6.22"	182 x 196 x 158 mm

SPECIFICATIONS	U.S. Measure	Metric Measure
<b>4DX10ER</b>		
Flow	1.0 gpm	3.8 lpm
Pump RPM	3450 rpm	3450 rpm
Stroke	0.078"	2.0 mm
<b>4DX15ER</b>		
Flow	1.5 gpm	5.7 lpm
Pump RPM	3450 rpm	3450 rpm
Stroke	0.118"	3.0 mm
<b>4DX20ER</b>		
Flow	2.0 gpm	7.6 lpm
Pump RPM	3450 rpm	3450 rpm
Stroke	0.157"	4.0 mm
<b>4DX27ER</b>		
Flow	2.7 gpm	10.2 lpm
Pump RPM	3450 rpm	3450 rpm
Stroke	0.220"	5.6 mm
<b>4DX30ER</b>		
Flow	3.0 gpm	11.4 lpm
Pump RPM	3450 rpm	3450 rpm
Stroke	0.244"	6.2 mm

#### ALTERNATIVE SEAL CONFIGURATION

MATERIAL	SUFFIX CODE	MAXIMUM TEMPERATURE	
NBR	—	140° F	(60° C)
FPM	.4110	180° F	(82° C)
ST	.4410	180° F	(82° C)

See **Tech Bulletin 002** for inlet conditions and RPM at high temperature.

$$\text{DETERMINING THE PUMP RPM} \quad \frac{\text{Rated gpm}}{\text{Rated rpm}} = \frac{\text{Desired gpm}}{\text{Desired rpm}}$$

$$\text{DETERMINING THE REQUIRED HP} \quad \text{hp (Electric Brake)} = \frac{\text{gpm} \times \text{psi}}{1460}$$

Refer to pump **Service Manual** for repair procedure and additional technical information.

## PARTS LIST

ITEM	PART NUMBER	MATERIAL	DESCRIPTION	QTY
5	549360	STCP R	Screw, HH (M6 x 14) (See Tech Bulletin 074)	3
8	547153	AL	Cover, Bearing	1
10	14041	NBR	O-Ring, Bearing Cover-70D	1
11	55337	NBR	Seal, Oil	1
15	14488	STL	Bearing, Ball, Inner	1
20	547048	TNM	Rod, Connecting	3
25	<b>132183</b>	CM	Crankshaft, 5/8", (2.0 mm), 4DX10ER	1
	<b>132185</b>	CM	Crankshaft, 5/8", (3.0 mm), 4DX15ER	1
	<b>132186</b>	CM	Crankshaft, 5/8", (4.0 mm), 4DX20ER	1
	<b>132187</b>	CM	Crankshaft, 5/8", (5.6 mm), 4DX27ER	1
	<b>132188</b>	CM	Crankshaft, 5/8", (6.2 mm), 4DX30ER	1
27	15710	STL	Bearing, Ball, Outer	1
32	549726	—	Cap, Vented with O-Ring (Rain Cap)	1
33	14179	NBR	O-Ring, Oil Filler Cap-70D	1
37	92241	PC	Gauge, Bubble Oil with Gasket (See Tech Bulletin 074)	1
38	44428	NBR	Gasket, Flat Flex, Oil Gauge-80D	1
48	44842	NY	Plug, Drain	1
49	14179	NBR	O-Ring, Drain Plug-70D	1
53	49801	AL	Crankcase	1
64	46229	CM	Pin, Crosshead	3
65	132190	BB	Rod, Plunger	3
70	47215	NBR	Seal, Oil	3
90	542403	CC	Plunger (M16 x 27)	3
98	46730	NBR	Washer, Seal-90D	3
99	542405	S	Retainer, Plunger (M6 x 35) (See Tech Bulletin 074)	3
100	46233	D	Retainer, Seal	3
106	† 48222	NBR	Seal, Low-Pressure, with SS-Spring	3
120	547357	BB	Case, Seal	3
121	13976	NBR	O-Ring, Seal Case-70D	3
125	46240	NBR	Seal, High-Pressure	3
160	13965	NBR	O-Ring, Seat, Inlet-70D	3
161	545177	S	Seat, Inlet	3
163	19285	NBR	O-Ring, Seat, Discharge-70D	3
164	545178	S	Seat, Discharge	3
166	547098	S	Valve	6
167	134579	S	Spring	6
168	543988	PVDF	Retainer, Spring, Inlet	3
169	49764	PVDF	Retainer, Spring, Discharge	3
172	142807	NBR	O-Ring, Plug-90D	3
174	547104	BB	Plug, Valve (M20 x 1.5) (See Tech Bulletin 074)	3
185	132192	FBB	Head, Manifold with Integral Regulator/Unloader Body	1
188	549357	STCP R	Screw, HSH (M6 x 60) (See Tech Bulletin 074)	6
196	101556	BB	Plug, Accessory (1/4" NPT[M])	1
255	30516	STZP R	Assembly, Bolt Mount	1
400	—	—	Regulator/Unloader, Integral (See Individual Parts)	1
460	107681	BB	Fitting, Discharge (3/8" NPT[M])	1

**Bold part numbers are unique to a particular pump model.**

R Components comply with RoHS Directive. † Production parts are different than repair parts.

\*Review individual parts in each kit for material code identification. For additional technical information see [www.catpumps.com/literature/tech-bulletins](http://www.catpumps.com/literature/tech-bulletins).

MATERIAL CODES (Not Part of Part Number): AL=Aluminum BB=Brass CC=Ceramic CM=Chrome-moly D=Acetal FBB=Forged Brass  
FPM=Fluorocarbon NBR=Medium Nitrile (Buna-N) NY=Nylon PC=Poly Carbonate PVDF=Polyvinylidene Fluoride S=304SS ST2=Special PTFE 2 STL=Steel  
STCP=Steel/Chrome Plated STZP=Steel/Zinc Plated TNM=Special High Strength

**NOTE:** Discard Key which may come standard with most motors and **use only the key included in this kit.**

# EXPLODED VIEW

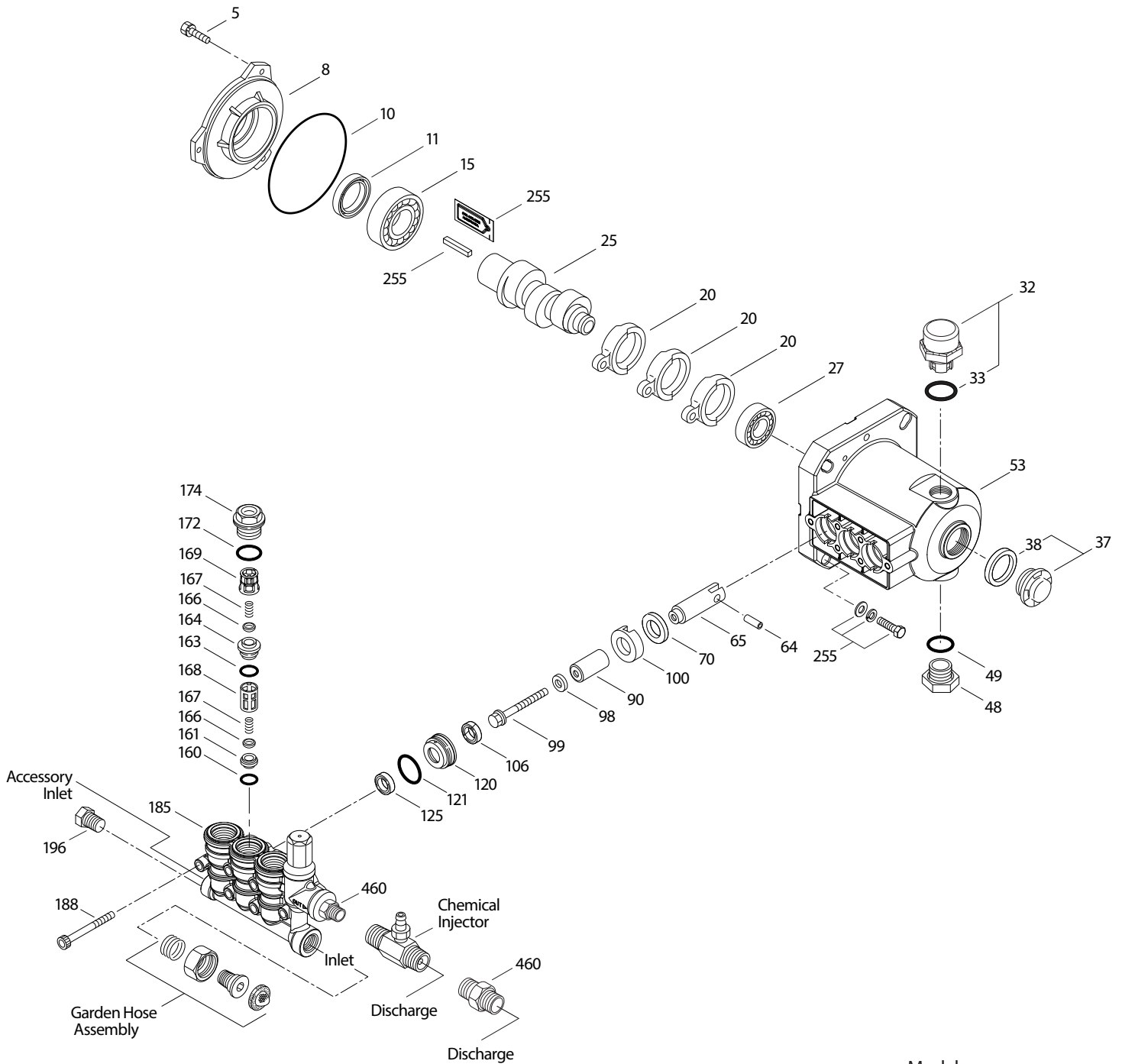

Models  
4DX10ER, 4DX15ER, 4DX20ER,  
4DX27ER, 4DX30ER  
February 2024

**Note: Pump is shipped with two black caps with O-rings for shipping purposes. Remove black cap with O-ring on top of pump and replace with loose red cap with O-ring as supplied in box.**

## OPTIONAL PARTS AND ACCESSORIES

PART	DESCRIPTION	QTY
941516	Assembly, Garden Hose (3/8" NPT[M])	1
134670	Plug, Valve with Port (1/4" NPT[F]) (Not shown)	1
990394	Kit, Oil Drain (3/8" NPT[M] x 24") (Not shown)	1
7231	Injector, Chemical, Fixed (1.8mm)	1
7232	Injector, Chemical, Fixed (2.1mm)	1

## SERVICE PARTS

PART	DESCRIPTION	QTY
<b>33053</b>	Seal Kit – Standard NBR	1
<b>76978</b>	Valve Kit – Standard NBR	1
6107	Oil, Bottle (21 oz) (Fill to Specified Crankcase Capacity Prior to Start-up)	1

## SEAL KITS One (1) seal kit required per pump

PUMP MODELS	NBR (STD)	FPM (.4110)	ST (.4410)
4DX10ER, 4XD15ER, 4DX20ER, 4DX27ER, 4DX30ER	33053	76453*	76878*

ITEM (Included in Seal Kits)				DESCRIPTION	QTY
98	46730	48394	48394	Washer, Seal	3
106	48222	670019	76089	Seal, Low-Pressure with S-Spring	3
121	13976	48522	48522	O-Ring, Seal Case	3
125	46240	76088	76088	Seal, High-Pressure	3

\*Review material codes for individual items (ST2 generally may be used as an alternative)

## VALVE KITS One (1) valve kit required per pump

PUMP MODELS	NBR (STD)	FPM (.4110)	ST (.4410)
4DX10ER, 4XD15ER, 4DX20ER, 4DX27ER, 4DX30ER	76978	76463	76463

ITEM (Included in Valve Kits)				DESCRIPTION	QTY
160	13965	76656	76656	O-Ring, Seat, Inlet	3
161	545177	545177	545177	Seat, Inlet	3
163	19285	14166	14166	O-Ring, Seat, Discharge	3
164	545178	545178	545178	Seat, Discharge	3
166	547098	547098	547098	Valve	6
167	134579	134579	134579	Spring	6
168	543988	543988	543988	Retainer, Spring, Inlet	3
169	49764	49764	49764	Retainer, Spring, Discharge	3
172	142807	547743	547743	O-Ring, Valve Plug	3

# INTEGRAL REGULATOR/UNLOADER

# EXPLODED VIEW

SPECIFICATIONS	U.S.	Metric
Flow	3.1 gpm	11.7 lpm
PSI Range	100–2000 psi	6.9–138 bar
Inlet Port	3/8" NPT(F)	3/8" NPT(F)
Discharge Port	3/8" NPT(M)	3/8" NPT(M)

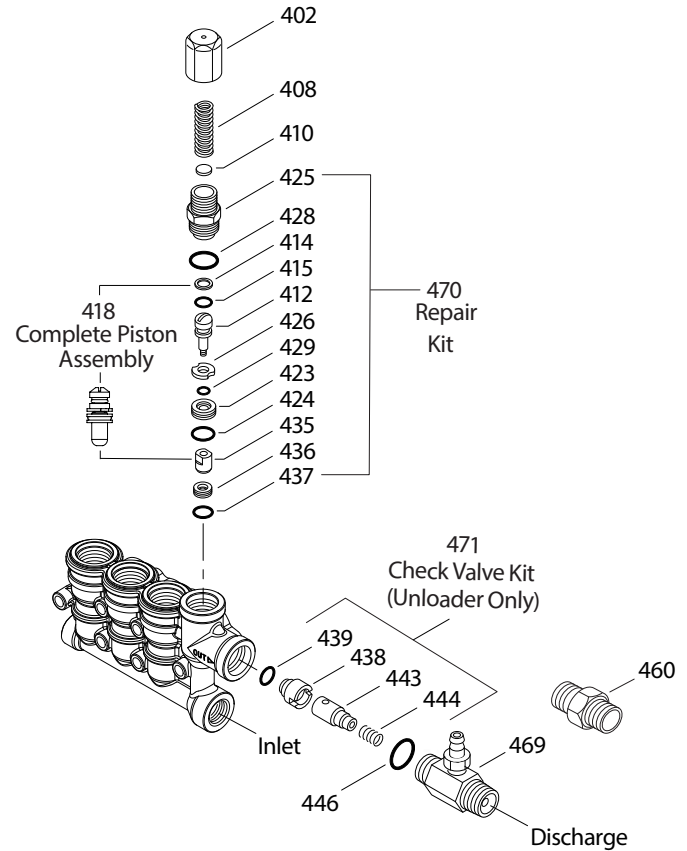

## PARTS LIST

ITEM	PN	MATL	DESCRIPTION	QTY
401	32088	NY	Handle, Adjustable (Not Shown)	1
402	46570	BB	Cap, Adjusting	1
408	33394	STZP R	Spring, Pressure	1
410	549352	STCP R	Retainer, Spring	1
412	46251	BB	Stem, Piston	1
414	28338	PTFE	Backup Ring, Piston Stem	1
415	22056	NBR	O-Ring, Piston Stem–70D	1
	76643	FPM	O-Ring, Piston Stem–70D	1
418	—	—	Assembly, Piston (Included In Repair Kit)	1
423	46249	BB	Retainer, Valve	1
424	13966	NBR	O-Ring, Valve Retainer (Outer)–70D	1
	76638	FPM	O-Ring, Valve Retainer (Outer)–70D	1
425	46248	BB	Retainer, Piston	1
426	46250	S	Washer	1
428	26133	NBR	O-Ring, Piston Retainer–80D	1
	14320	FPM	O-Ring, Piston Retainer–75D	1
429	17399	NBR	O-Ring, Valve Retainer (Inner)–80D	1
	14160	FPM	O-Ring, Valve Retainer (Inner)–80D	1
435	548193	S	Valve	1
436	46253	S	Seat	1

ITEM	PN	MATL	DESCRIPTION	QTY
437	13963	NBR	O-Ring, Seat–70D	1
	14303	FPM	O-Ring, Seat–70D	1
438	46254	NY	Seat, Check Valve	1
439	13963	NBR	O-Ring, Seat, Check Valve–70D	1
	14303	FPM	O-Ring, Seat, Check Valve–70D	1
443	541060	BB	Valve, Check with O-Ring	1
444	45924	S	Spring	1
446	26133	NBR	O-Ring, Body–80D	1
	14320	FPM	O-Ring, Body–75D	1
460	107681	BB	Fitting, Discharge (3/8" NPT[M])	1
468	76754	NBR	Kit, O-Ring (Includes: 414, 415, 424, 428, 429, 437) <b>Standard</b>	1
	76467	FPM	Kit, O-Ring (Includes: 414, 415, 424, 428, 429, 437) <b>.4110, .4410</b>	1
469	7231	BB	Injector, Chemical Fixed (1.8 mm)	1
	7232	BB	Injector, Chemical Fixed (2.1 mm)	1
470	76031	NBR	Kit, Repair (Includes: 418, 425, 428, 436, 437) <b>Standard</b>	1
	76468	FPM	Kit, Repair (Includes: 418, 425, 428, 436, 437) <b>.4110, .4410</b>	1
471	† 76146	NBR	Kit, Check Valve (Includes: 438, 439, 443, 444, 446) <b>Standard</b>	1
	† 76469	FPM	Kit, Check Valve (Includes: 438, 439, 443, 444, 446) <b>.4110, .4410</b>	1

*Italics are optional items.* R Components comply with RoHS Directive. † Production parts are different than repair parts.  
 MATERIAL CODES (Not Part of Part Number): BB=Brass FPM=Fluorocarbon NBR=Medium Nitrile (Buna-N) NY=Nylon PTFE=Pure Polytetrafluoroethylene  
 S=304SS STCP=Steel/Chrome Plated STZP=Steel/Zinc Plated

## MODELS 7231, 7232 FIXED CHEMICAL INJECTOR

SPECIFICATIONS	U.S.	Metric
GPM	3.1 gpm	11.7 lpm
Nozzle Orifice (7231)	1.8 mm	1.8 mm
Nozzle Orifice (7232)	2.1 mm	2.1 mm
Hose Barb	1/4"	1/4"
Tapped Barb	3/32" UNF	3/32" UNF
Inlet Port	M18 x 1.0	M18 x 1.0
Discharge Port	3/8" NPT(M)	3/8" NPT(M)
Weight	5.3 oz	0.15 kg
Dimensions	2 x 1 x 1.75"	52 x 25 x 45 mm

## PARTS LIST

ITEM	PN	MATL	DESCRIPTION	QTY
472	46630	BB	Barb, Tapped	1
476	14187	NBR	O-Ring, Barb-70D	1
	77320	FPM	O-Ring, Barb	1
477	46259	S	Ball	1
478	46250	S	Spring	1
479	46257	BB	Orifice (1.8 mm)	1
	46531	BB	Orifice (2.1 mm)	1
480	—	BB	Body	1
483	76176	NBR	Kit, Repair (Includes: 476, 477, 478) <b>Standard</b>	1
	76476	FPM	Kit, Repair (Includes: 476, 477, 478) <b>.4110, 4410</b>	1

MATERIAL CODES (Not Part of Part Number):

BB=Brass FPM=Fluorocarbon NBR=Medium Nitrile (Buna-N) S=304SS

## EXPLODED VIEW

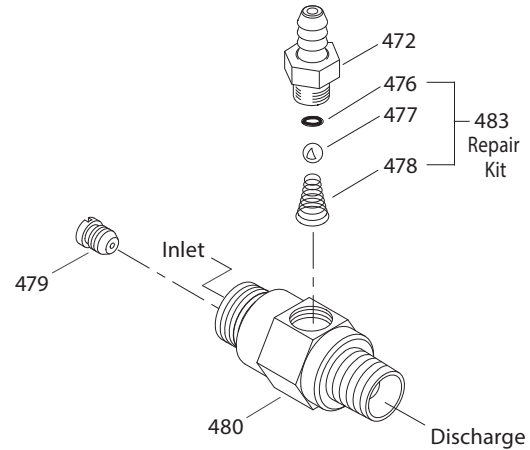

## PERFORMANCE CHART

Orifice Size	Maximum Injecting Pressure	Minimum Chemical Draw	Pressure Drop Across Orifice
1.8 mm	100 psi	52 oz/min	100 psi
2.1 mm	250 psi	37.2 oz/min	141 psi

**NOTE:** Optimum performance of Chemical Injector occurs with a 35 ft. high-pressure hose with a minimum 3/8" ID. The type of hose, extended lengths, reduced ID and fittings may create additional backpressure above the maximum injecting pressure rating of the injector and prevent it from drawing chemicals.

## REGULATING DEVICE

An integral regulator or unloader with built-in bypass is part of the discharge manifold to provide system pressure regulation and pump protection. An optional fixed chemical injector is available. (See back page for proper model identifications)

## OPERATION

Pump should be purged of air before commencing with operation. Liquid must flow through the pump without discharge restriction to ensure full system pressure is reached. Install a pressure gauge close to the manifold head of the pump to assist in setting system pressure and to periodically monitor system pressure. Setting and adjusting the regulator or unloader pressure must be done with the system turned on. Start the system with the regulator or unloader backed off to the lowest pressure setting (counterclockwise direction). Squeeze the trigger and read the pressure on the gauge at the pump. Do not read pressure at the gun or nozzle. If more pressure is desired, release the trigger, turn adjusting cap one quarter turn in a clockwise direction. Squeeze the trigger and read the pressure. Repeat this process until the desired system pressure is reached.

**NOTE:** Pressure is not set at the factory.

## SERVICE

The regulator or unloader should be serviced on the same schedule as the seals in the pump. Refer to 4DX Service Manual for start-up, servicing of seals and valves, torque requirements and diagnosis and maintenance chart.

## ELECTRIC MOTOR OPTIONS

### 60 HERTZ

#### 1750 RPM, 1PH

HP	Part #	Voltage	Enclosure
0.5	8105	115/*230	TEFC
0.75	8175	115/*230	TEFC
1	8110	115/*230	TEFC
1.5	8115	115/208-230	TEFC
2	8120	115/208-230	TEFC
2.5	8125	115/230	TEFC

#### 3450 RPM, 1PH

HP	Part #	Voltage	Enclosure
1.5	8054	115/230	TEFC
2	999943	115/230	TEFC
3	992139	115/*230	ODP

### 50 HERTZ

#### 1450 RPM, 1PH

HP	Part #	Voltage	Enclosure
1	8064	110/220	TEFC
1.5	8115	110/220	TEFC
2.0	8120	110/220	TEFC
2.2	8125	110/220	TEFC

#### 1750 RPM, 3PH

HP	Part #	Voltage	Enclosure
0.33	990324	200-230/460	TEFC
0.5	997671	*230/460	TEFC
1	999189	*230/460	TEFC
1.5	998843	*230/460	TEFC
2	899247	*230/460	TEFC
2.5	8126	208-230/460	TEFC

#### 3450 RPM, 3PH

HP	Part #	Voltage	Enclosure
1.5	994794	*230/460	TEFC
3	8053	230/460	TEFC

#### 1450 RPM, 3PH

HP	Part #	Voltage	Enclosure
2.5	8126	190-220/380-415	TEFC

\* Prior to Department of Energy (DOE) EERE - 2020 - BT - TP - 0011 Motor was Name-Plate Rated 208/230 Volt

## MOTOR DIMENSION 4DX SERIES

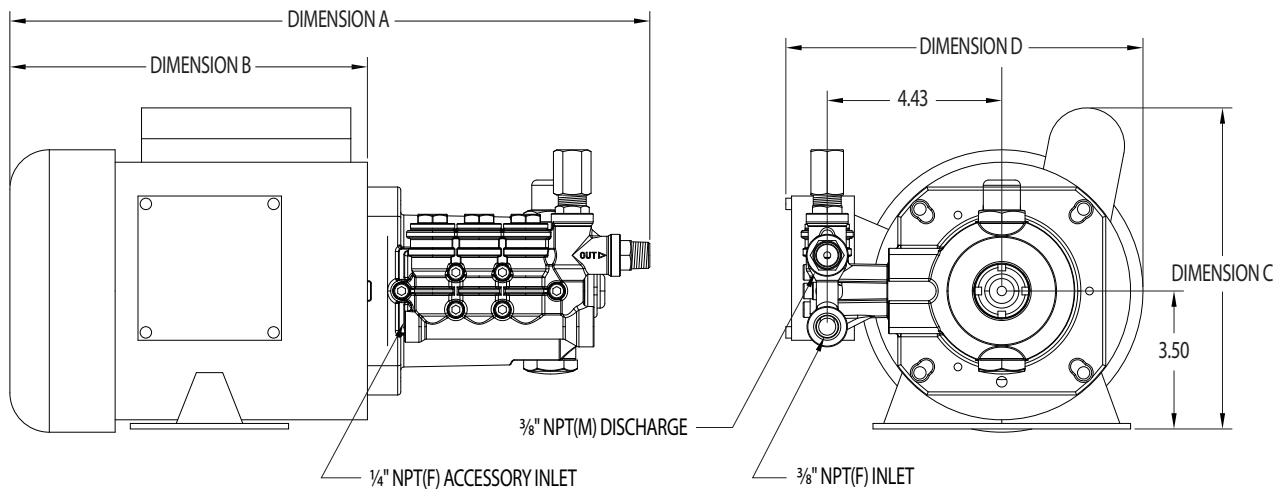

MODEL	8053	8054	8064	8105	8110	8115	8120	8125
Dimension A	18.8"	17.5"	18.0"	16.2"	19.0"	19.3"	19.3"	19.3"
Dimension B	11.7"	10.3"	10.8"	9.1"	11.8"	12.4"	12.4"	12.4"
Dimension C	7.3"	8.7"	8.7"	8.2"	18.8"	9.7"	9.7"	9.7"
Dimension D	9.7"	9.5"	9.3"	9.1"	9.7"	9.7"	9.7"	9.7"

MODEL	8126	8175	899247	990324	992139	994794	997671	998843	999189	999943
Dimension A	21.7"	16.2"	18.6"	16.6"	19.0"	18.0"	16.5"	17.4"	17.4"	18.0"
Dimension B	14.0"	9.1"	11.4"	9.4"	11.8"	10.9"	9.3"	10.3"	10.3"	10.8"
Dimension C	7.3"	8.2"	7.1"	7.3"	8.15"	7.3"	7.3"	7.1"	8.2"	8.7"
Dimension D	9.7"	9.1"	9.0"	9.7"	8.3"	9.7"	9.7"	9.7"	9.1"	9.3"

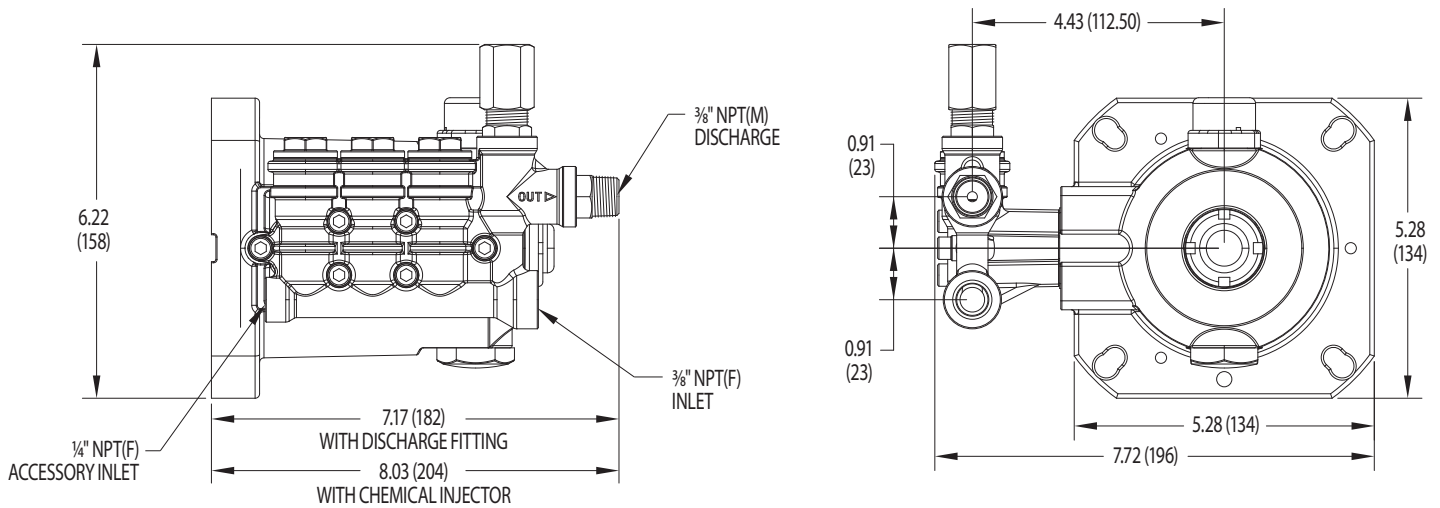

Base Models 4DX10ER, 4DX15ER, 4DX20ER, 4DX27ER, 4DX30ER

### 4DX Pump Series Selection Chart

Pump Series										Pump Flow/RPM			
4	D	X								GPM	RPM	Alt. GPM	Alt. RPM
			1	0						1.0	3450	0.5	1725
			1	5						1.5	3450	0.75	1725
			2	0						2.0	3450	1.0	1725
			2	7						2.7	3450	1.35	1725
			3	0						3.0	3450	1.5	1725
							E			Electric, 5/8" Hollow Shaft			
								R		Regulating Device = Regulator			
								U		Regulating Device = Unloader			
									I	Fixed Chemical Injector			
									F	Garden Hose Fitting			
										.4110	ST2 High-Pressure Seals and FPM Low-Pressure Seals and O-Rings		
										.4410	ST2 High and Low-Pressure Seals, FPM O-Rings		

#### Examples:

4DX10ER = 1 gpm (3450 rpm), Regulator, standard inlet - 3/8" NPT(F)

4DX15EUIF = 1.5 gpm (3450 rpm), Unloader, Chemical Injector, Garden Hose Inlet Fitting

4DX30ER.4410 = 3 gpm (3450 rpm), Regulator, standard inlet - 3/8" NPT(F), with ST2 High and Low-Pressure Seals and FPM O-rings

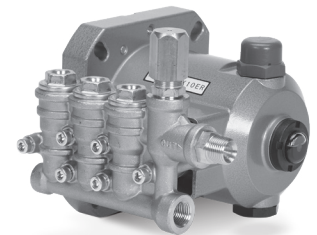

Model 4DX10ER

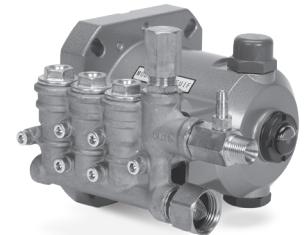

Model 4DX15EUIF

#### ⚠ CAUTIONS AND WARNINGS

All high-pressure systems require a primary pressure regulating device (e.g. regulator, unloader) and a secondary pressure relief device (e.g. pop-off valve, relief valve). Failure to install such relief devices could result in personal injury or damage to pump or property. Cat Pumps does not assume any liability or responsibility for the operation of a customer's high-pressure system.

Read all CAUTIONS and WARNINGS before commencing service or operation of any high-pressure system. The CAUTIONS and WARNINGS are included in each Service Manual and with each Accessory Data sheet. CAUTIONS and WARNINGS can also be viewed online at [www.catpumps.com/dynamic-literature/cautions-and-warnings](http://www.catpumps.com/dynamic-literature/cautions-and-warnings) or can be requested directly from Cat Pumps.

#### WARRANTY

View the Limited Warranty online at [www.catpumps.com/literature/cat-pumps-limited-warranty](http://www.catpumps.com/literature/cat-pumps-limited-warranty)