

DATA SHEET

DIRECT DRIVE PLUNGER PUMPS

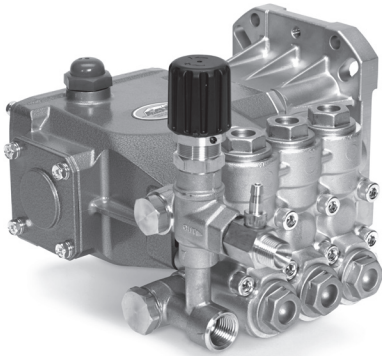

Brass Models: **66DX30G1I, 66DX35G1I, 66DX40G1I**



FEATURES

- Triplex plunger design ensures high efficiency and low pulsation.
- Compact flange mount permits easy, direct mounting to most gas engines*
- Modular regulating unloader with built-in bypass ensures system pressure control and pump protection.**
- Fixed chemical injector aids in cleaning flexibility.
- Pump comes standard with NBR seals. Alternative seal materials are available for higher temperature or chemical compatibility.

*Gas Mounting Flange: SAE J609, Flange B, Extension 4 (1" Ø), Shaft Length = 3¼", Pilot Ø = 5¾", B.C. Ø = 6½", Thread ¾"-16 UNC Tap

**Available without an unloader. (66DX30GGI, 66DX35GGI, 66DX40GGI)

COMMON

SPECIFICATIONS

	U.S. Measure	Metric Measure
Pump RPM	3400 rpm	3400 rpm
Inlet Pressure Range	Flooded to 75 psi	Flooded to 5.2 bar
Max. Liquid Temperature (NBR)	140° F	60° C
Alternate seals available for higher temperature up to 180° F		
Bore	0.551"	14 mm
Crankcase Capacity	18.0 oz	0.53 l
Inlet Ports (2)	½" NPT(F)	½" NPT(F)
Discharge Ports (2)	¾" NPT(F)	¾" NPT(F)
Shaft Diameter (Hollow)	1.0"	25.4 mm
Engine Mounting Face	6.5"	6.5"
Weight	26.15 lbs	11.9 kg
Dimensions (Pump Only)	11.73 x 10.51 x 8.15"	298 x 267 x 207 mm

SPECIFICATIONS

	U.S. Measure	Metric Measure
Model 66DX30G1I		
Flow	3.0 gpm	11.4 lpm
Pressure Range	100–4000 psi	6.9–275 bar
Stroke	0.339"	8.6 mm
Model 66DX35G1I		
Flow	3.5 gpm	13.2 lpm
Pressure Range	100–4000 psi	6.9–275 bar
Stroke	0.394"	10.0 mm
Model 66DX40G1I		
Flow	4.0 gpm	15.0 lpm
Pressure Range	100–4000 psi	6.9–275 bar
Stroke	0.449"	11.4 mm

ALTERNATIVE SEAL CONFIGURATION

MATERIAL	SUFFIX CODE	MAXIMUM TEMPERATURE	
NBR	—	140° F	(60° C)
FPM	.0110	180° F	(82° C)

See **Tech Bulletin 002** for inlet conditions and RPM at high-temperature.

TORQUE AND HORSEPOWER REQUIREMENTS

MODELS	FLOW		PRESSURE				PUMP RPM		
	GPM	LPM	PSI	BAR	PSI	BAR			
			2500	172	3000	207	4000	275	
Torque									
66DX30G1I	3.0	11.4	7.9 ft-lbs	9.5 ft-lbs	12.7 ft-lbs	3400			
66DX35G1I	3.5	13.2	9.3 ft-lbs	11.1 ft-lbs	14.8 ft-lbs	3400			
66DX40G1I	4.0	15.0	10.6 ft-lbs	12.7 ft-lbs	16.9 ft-lbs	3400			
Horsepower*									
66DX30G1I	3.0	11.4	6.6 hp	7.8 hp	10.5 hp	3400			
66DX35G1I	3.5	13.2	7.7 hp	9.2 hp	12.3 hp	3400			
66DX40G1I	4.0	15.0	8.9 hp	10.5 hp	14.0 hp	3400			

*HP is for estimate only. Torque values of the engine at given rpm should be used to determine correct size of engine.

Consult engine manufacture for actual torque available at required speed.

DETERMINING THE PROPER TORQUE

$$\text{Torque (ft-lbs)} = 3.6 \times \frac{\text{gpm} \times \text{psi}}{\text{rpm}}$$

DETERMINING THE REQUIRED HP

$$\text{Engine hp (Estimated)} = \frac{\text{gpm} \times \text{psi}}{1140}$$

DETERMINING THE PUMP RPM

$$\frac{\text{Rated gpm}}{\text{Rated rpm}} = \frac{\text{Desired gpm}}{\text{Desired rpm}}$$

Refer to pump **Service Manual** for repair procedure and additional technical information.

EXPLODED VIEW

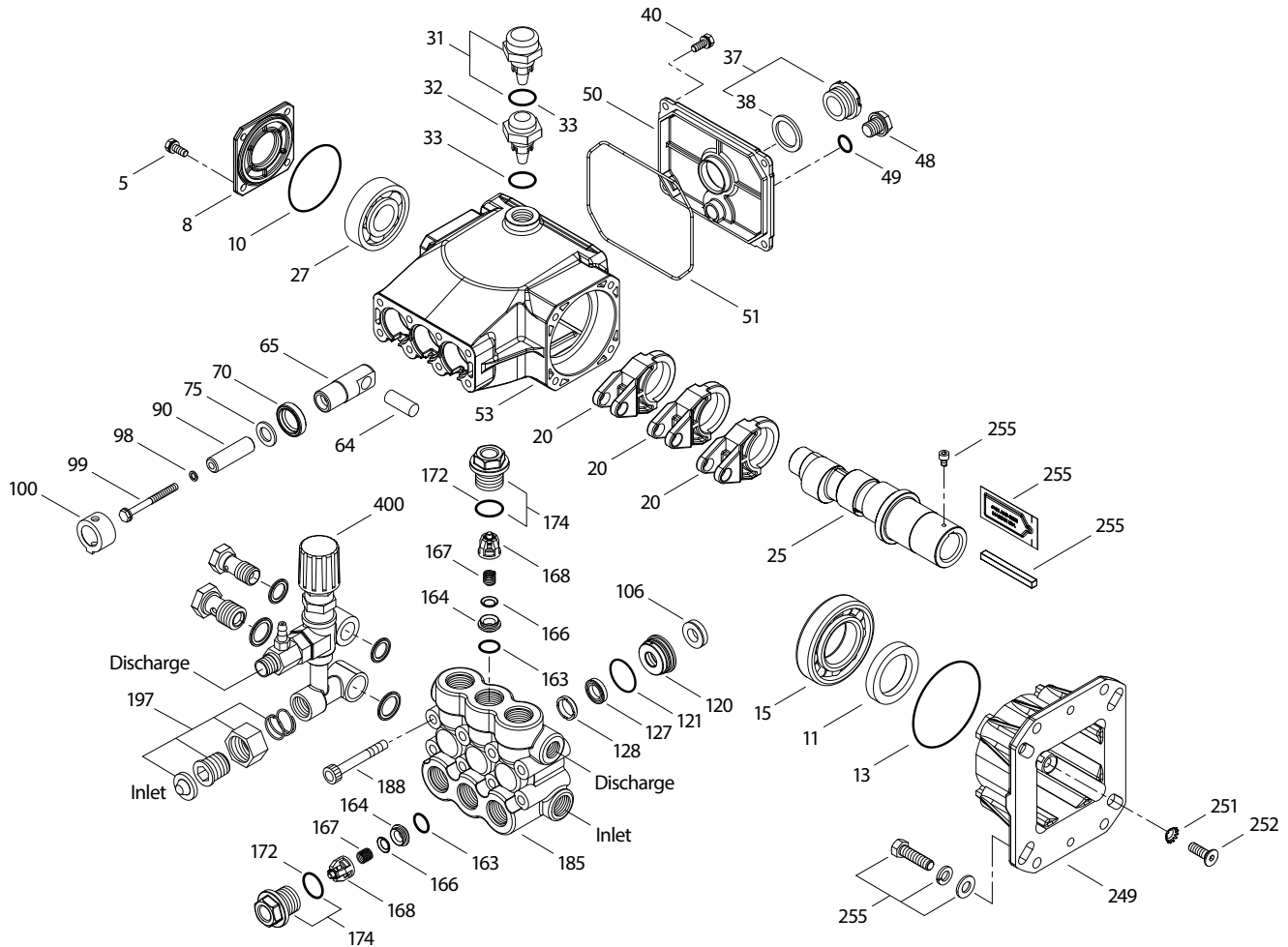

PARTS LIST

ITEM	P/N	MATL DESCRIPTION	QTY	ITEM	P/N	MATL DESCRIPTION	QTY
5	125824	STCP R Screw, HHC (M6 x 16) (See Tech Bulletin 074)	4	75	48754	NBR Slinger, Barrier	3
8	48259	AL Cover, Bearing, Blind	1	90	48752	CC Plunger (M14 x 47)	3
10	14028	NBR O-Ring, Bearing Cover-70D	1	98	46730	NBR Washer Seal, Plunger Retainer-90D	3
11	125351	NBR Seal, Oil, Crankshaft	1	99	† 48201	SS Retainer, Plunger (See Tech Bulletin 074)	3
13	14037	NBR O-Ring, Bearing Cover	1	100	48755	NY Retainer, Seal	3
15	146421	STL Bearing, Inner, Ball	1	106	45188	NBR Seal, Low-Pressure with S-Spring	3
20	48843	TNM Rod, Connecting	3	120	48759	BB Case, Seal	3
25	48970	CM Crankshaft, 1" (8.6 mm) (30G11)	1	121	13980	NBR O-Ring, Seal Case-70D	3
	48977	CM Crankshaft, 1" (10.0 mm) (35G11)	1	127	48758	SNG V-Packing	3
	48839	CM Crankshaft, 1" (11.4 mm) (40G11)	1	128	48757	NY Adapter, Male	3
27	14480	STL Bearing, Outer, Ball	1	163	17547	NBR O-Ring, Seat-85D	6
31	127409	— Cap, Vented with O-Ring (Rain Cap)	1	164	45790	S Seat	6
32	46798	— Cap, Domed, Oil Filler	1	166	46429	S Valve	6
33	14179	NBR O-Ring, Filler Cap-70D	1	167	43750	S Spring	6
37	92241	PC Gauge, Oil Bubble with Gasket-80D (See Tech Bulletin 074)	1	168	† 44565	PVDF Retainer, Spring	6
38	44428	NBR Gasket, Flat, Oil Gauge-80D	1	172	17616	NBR O-Ring, Valve Plug-80D	6
40	125824	STCP R Screw, HHC (M6 x 16) (See Tech Bulletin 074)	4	174	48760	BB Plug, Valve with O-Ring (See Tech Bulletin 074)	6
48	25625	STCP Plug, Drain (1/4" x 19 BSP)	1	185	48846	BB Head, Manifold	1
49	23170	NBR O-Ring, Drain Plug-70D	1	188	126512	STCP R Screw, HSH (M8 x 65) (See Tech Bulletin 074)	8
50	48862	AL Cover, Rear	1	197	941517	BB Assembly, GH [1/2" NPT(M) x 3/4" GH(F)]	1
51	14048	NBR O-Ring, Rear Cover	1	249	48841	AL Flange, Adapter	1
53	48830	AL Crankcase	1	251	126746	STCP R Lockwasher, Conical (M8)	4
64	46404	CM Pin, Crosshead	3	252	46403	STL Screw, FH (M8 x 25)	4
65	48845	BB Rod, Plunger	3	255	30510	STZP Assembly, Bolt Mount	1
70	48911	NBR Seal, Oil, Crankcase	3	400	7860	BB Unloader Assembly with Fixed Injector (Eff. 04/07)	1

Bold Part Numbers are unique to a particular pump model. Italics are optional items.

R Components comply with RoHS Directive. † Production parts different from service parts. For additional technical information see www.catpumps.com/literature/tech-bulletins.

MATERIAL CODES (Not Part of Part Number): AL=Aluminum BB=Brass CC=Ceramic CM=Chrome-moly FPM=Fluorocarbon NBR=Medium Nitrile (Buna-N) NY=Nylon

PC=Poly Carbonate PVDF=Polyvinylidene Fluoride S=304SS SNG=Special Blend (Buna) SS=316SS STCP=Steel/Chrome Plated STG=Special Blend PTFE White

STL=Steel STZP=Steel/Zinc Plated ST4=Special PTFE4 TNM=Special High Strength

MODEL 7860 UNLOADER WITH INJECTOR

SPECIFICATIONS

	U.S.	Metric
Flow Range	3.0–5.0 gpm	11.4–19.0 lpm
PSI Range	700–4000 psi	50–275 bar
Inlet Port, Side	½" NPT(F)	½" NPT(F)
Discharge Port, Front	¾" NPT(M)	¾" NPT(M)
Weight	35.2 oz	1.0 kg
Dimensions	4.65 x 170 x 6.75"	118 x 43 x 171 mm

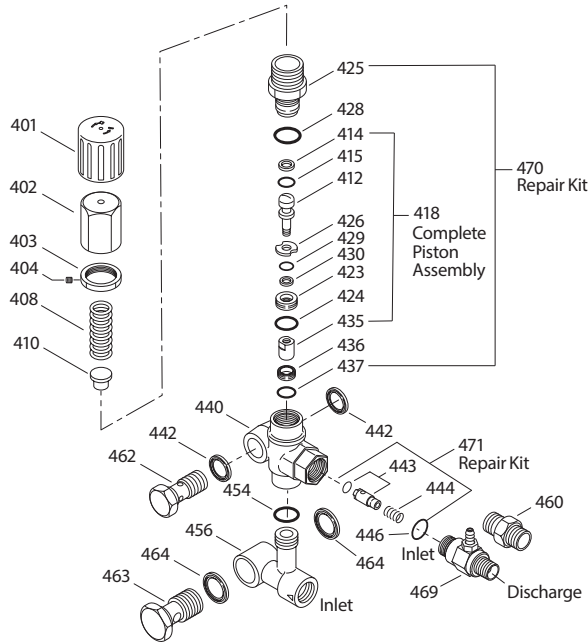

PARTS LIST

ITEM	P/N	MATL	DESCRIPTION	QTY
401	49100	NY	Handle, Adjusting (Black)	1
402	49099	BB	Cap, Adjusting	1
403	125521	BB	Nut, Locking (M25 x 1)	1
404	88953	S	Screw, Set (M4 x 4)	1
408	45198	ZP R	Spring, Pressure	1
410	49101	STZP R	Retainer, Spring	1
412	49103	S	Stem, Piston	1
414	129638	PTFE	Backup Ring, Piston Stem	1
415	49104	NBR	O-Ring, Piston Stem–90D	1
418	—	BB	Assembly, Piston (Included in Repair Kit)	1
423	49105	BB	Retainer, Valve	1
424	49106	NBR	O-Ring, Valve Retainer–70D	1
425	49102	BB	Retainer, Piston	1
426	49107	S	Washer	1
428	26133	NBR	O-Ring, Piston Retainer–80D	1
429	22056	NBR	O-Ring, Valve Retainer–70D	1
430	49123	D	Backup Ring, Valve Retainer	1
435	49383	S	Valve/Ball Assembly	1
436	49384	S	Seat	1
437	13965	NBR	O-Ring, Seat–70D	1
440	—	BB	Valve Body	1
442	49121	STL	Washer, Seal (¾")	2
443	49245	BB	Valve, Check with NBR O-Ring	1
444	117275	S	Spring, Check Valve	1
446	26133	NBR	O-Ring, Body–80D	1
454	11346	NBR	O-Ring, Manifold–70D	1
456	—	BB	Manifold	1
460	126974	BB	Fitting, Discharge (¾" NPT[M])	1
462	49120	BB	Screw, Flo-Thru (¾" NPT[M])	1
463	49117	BB	Screw, Flo-Thru (½" NPT[M])	1
464	49118	STL	Washer, Seal (½")	2
468	31708	NBR	Kit, O-Ring (Includes: 414, 415, 424, 428–430, 437, 446, 454)	1
469	7367	BB	Injector, Chemical Fixed	1
470	31556	NBR	Kit, Repair (Includes: 418, 425, 428, 436, 437)	1
471	76185	NBR	Kit, Check Valve (Includes: 443, 444, 446)	1

Italics are optional items. R Components comply with RoHS Directive.

MATERIAL CODES (Not Part of Part Number): BB=Brass D=Acetal
NBR=Medium Nitrile (Buna-N) NY=Nylon PTFE=Pure Polytetrafluoroethylene
S=304SS STL=Steel STZP=Steel/Zinc Plated ZP=Zinc Plated

MODEL 7367 FIXED CHEMICAL INJECTOR

SPECIFICATIONS

	U.S.	Metric
Flow Range	3.0–5.0 gpm	11.4–19.0 lpm
Nozzle Orifice	2.1 mm	2.1 mm
Hose Barb - Extension	¼"	¼"
Inlet Port	M20 x 1	M20 x 1
Discharge Port	¾" NPT(M)	¾" NPT(M)
Weight	5.3 oz	0.15 kg
Dimensions	2.0 x 1.0 x 1.75"	52 x 25 x 44 mm

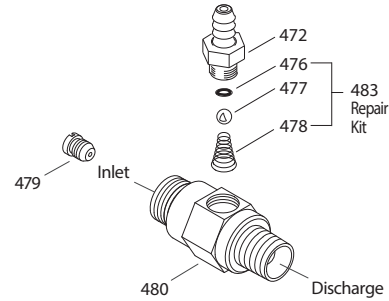

PARTS LIST

ITEM	P/N	MATL	DESCRIPTION	QTY
472	49132	BB	Barb, Fix	1
476	—	NBR	O-Ring, Barb–70D	1
477	—	S	Ball	1
478	—	S	Spring	1
479	—	S	Orifice	1
480	—	BB	Body	1
483	76176	NBR	Kit, Repair (Includes: 476, 477, 478)	1

MATERIAL CODES (Not Part of Part Number):
BB=Brass NBR=Medium Nitrile (Buna-N) S=304SS

CHEMICAL INJECTOR PERFORMANCE CHART

Pump Flow	Orifice Size	Maximum Injecting Pressure	Maximum Chemical Draw	Pressure Drop Across Orifice
3.0	2.1 mm	190 psi	70.0 oz/min	136 psi
3.5	2.1 mm	260 psi	74.2 oz/min	245 psi
4.0	2.1 mm	358 psi	76.8 oz/min	288 psi

Optimum performance of chemical injector occurs with a 35 ft high-pressure hose with a minimum ¾" I.D. The type of hose, extended lengths, reduced I.D. and fittings may create additional back pressures above the maximum injecting pressure rating of the injector and prevent it from drawing chemical.

UNLOADER TYPE

A modular regulating unloader with chemical injector comes with each 66DX pump to provide system pressure regulation, pump protection and metered chemical application.

OPERATION:

Purge pump of air before commencing operation by allowing liquid to flow through the pump without discharge restriction. Removing trapped air will ensure full system pressure can be obtained. Install a pressure gauge close to the manifold head of the pump to assist in setting system pressure and to periodically monitor system pressure. Setting and adjusting the unloader pressure must be done with the system turned on. Start the system with the unloader backed off to the lowest pressure setting (counterclockwise direction). Squeeze the trigger and read the pressure on the gauge at the pump. Do not read pressure at the gun or nozzle. If more pressure is desired, release the trigger, turn adjusting cap one quarter turn in a clockwise direction. Squeeze the trigger and read the pressure. Repeat this process until the desired system pressure is reached. Thread locking nut up to adjusting cap and tighten set screw. All high-pressure systems should have a secondary relief valve. Set secondary relief valve 200–300 psi above the unloader setting.

NOTE: Pressure is not set at the factory.

SERVICE:

The unloader should be serviced on the same schedule as the seals in the pump. Refer to 66DX Service Manual for start-up, servicing of seals and valves, torque requirements and Diagnosis/Maintenance chart.

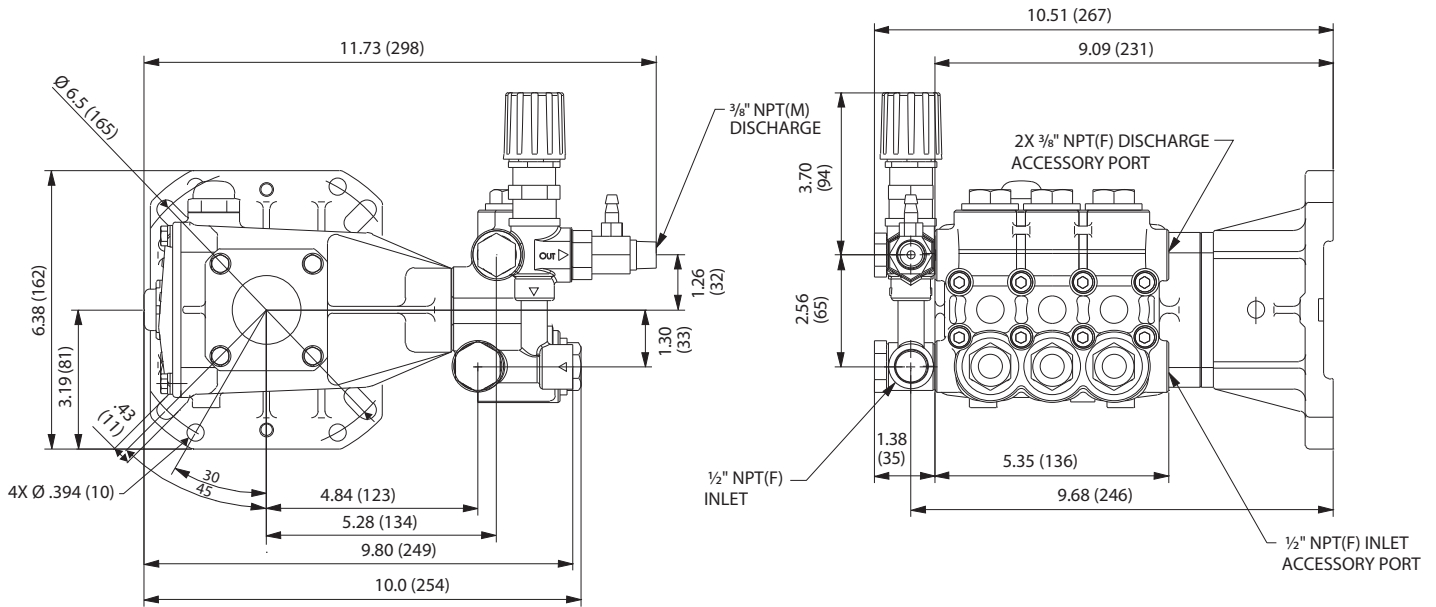

SEAL KITS One (1) seal kit required per pump

PUMP MODEL	NBR (STD)	FPM (.0110)
66DX30G1I, 66DX35G1I, 66DX40G1I	34262	32376*

ITEM (Included in Seal Kits)			DESCRIPTION	QTY
98	46730	48394	Washer, Seal	3
106	45188	704649	Seal, Low-Pressure with S-Spring	3
121	13980	14330	O-Ring, Seal Case	3
127	48758	49201	V-Packing	3
128	48757	48757	Adapter, Male	3

* Review material codes for individual items (STG generally may be used as alternative)

VALVE KITS Two (2) valve kits required per pump

PUMP MODEL	NBR (STD)	FPM (.0110)
66DX30G1I, 66DX35G1I, 66DX40G1I	34260	32375

ITEM (Included in Valve Kits)			DESCRIPTION	QTY
163	17547	11685	O-Ring, Seat	3
164	45790	45790	Seat	3
166	46429	46429	Valve	3
167	43750	43750	Spring	3
168	46583	46583	Retainer, Spring	3
172	17616	11686	O-Ring, Valve Plug	3

⚠ CAUTIONS AND WARNINGS

All high-pressure systems require a primary pressure regulating device (e.g. regulator, unloader) and a secondary pressure relief device (e.g. pop-off valve, relief valve). Failure to install such relief devices could result in personal injury or damage to pump or property. Cat Pumps does not assume any liability or responsibility for the operation of a customer's high-pressure system. Read all CAUTIONS and WARNINGS before commencing service or operation of any high-pressure system. The CAUTIONS and WARNINGS are included in each Service Manual and with each Accessory Data sheet. CAUTIONS and WARNINGS can also be viewed online at www.catpumps.com/dynamic-literature/cautions-and-warnings or can be requested directly from Cat Pumps.

WARRANTY

View the Limited Warranty online at www.catpumps.com/literature/cat-pumps-limited-warranty