



LPS Monitors

PLC/PC Interface **30664**
Indicator light **30664.120AC**

PLC/PC Interface **30290**
Indicator light **30290.120AC**

PLC/PC Interface **30292**
(Corrosion Resistant)

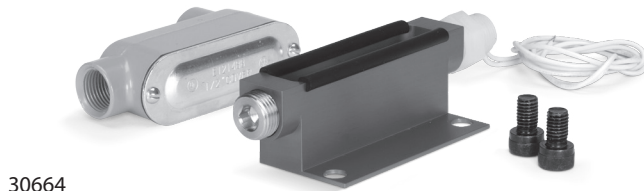

30664

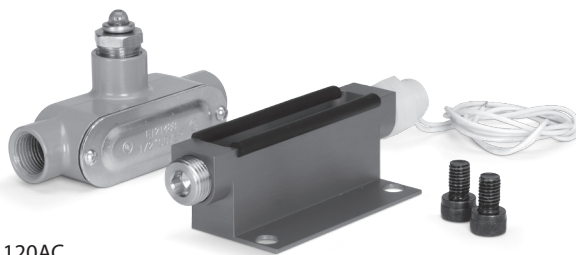

30664.120AC

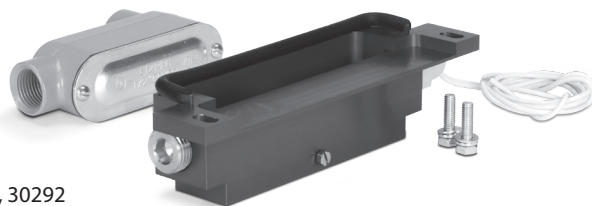

30290, 30292

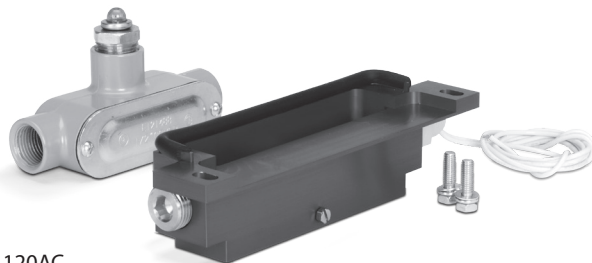

30290.120AC

SELECTION

P/N	FITS THESE PUMP MODELS
30664 and 30664.120AC	650, 651, 660, 661, 661C, 661D, 681, 681K, 1050, 1051, 1051C, 1051D, 1057, 1530, 1531, 1540, 1540E, 1541, 1560, 1810, 1810K, 1851, 1851K, 1861, 1861K
30290, 30292 30290.120AC	1520, 1521, 2510, 2511, 2520, 2520C, 2521, 2530, 2530E, 2531, 2537, 2831, 2831K, 3501, 3501C, 3507, 3507C, 3511, 3511C, 3517, 3517C, 3520, 3520C, 3521, 3521C, 3527, 3531, 3531C, 3535, 3535C, 3537, 3541, 3541C, 3545, 3560, 3801, 3801K, 3811, 3811K, 3821, 3821K, 3831, 3831K, 3841, 3841K

FEATURES

- Runs your system more efficiently avoiding unplanned shutdowns, improving profitability.
- Improves your pump maintenance management decisions.
- Can configure the monitor to PLC or PC based systems.
- Monitor output configurable to either normally open or closed operation (NO or NC)
- Optional light to alert maintenance personnel when pump seal replacement is required.

SPECIFICATIONS

	U.S. Measure	Metric Measure
Maximum switch pressure	100 psi	(7 bar)
Switch Ratings	240VAC = 0.14A	(240VAC = 0.14A)
.....	120VAC = 0.28A	(120VAC = 0.28A)
.....	120VDC = 0.07A	(120VDC = 0.07A)
.....	12VDC = 0.28A	(12VDC = 0.28A)
Fitting (Float Switch)	1/2" NPTM	(1/2" NPTM)
Weight	0.75 lbs	(0.34 kg)
	<i>(30664 w/elbow junction box)</i>	
Weight	1.15 lbs	(0.52 kg)
	<i>(30290, 30292 w/tee junction box/light)</i>	

⚠ CAUTIONS AND WARNINGS

All High Pressure Systems require a primary pressure regulating device (i.e. regulator, unloader) and a secondary pressure relief device (i.e. pop-off valve, relief valve). Failure to install such relief devices could result in personal injury or damage to pump or property. CAT PUMPS does not assume any liability or responsibility for the operation of a customer's high pressure system.

Read all CAUTIONS and WARNINGS before commencing service or operation of any high pressure system. The CAUTIONS and WARNINGS are included in each service manual and with each Accessory Data sheet. CAUTIONS and WARNINGS can also be viewed online at www.catpumps.com/cautions-warnings or can be requested directly from CAT PUMPS.

WARRANTY

View the Limited Warranty on-line at www.catpumps.com/warranty.

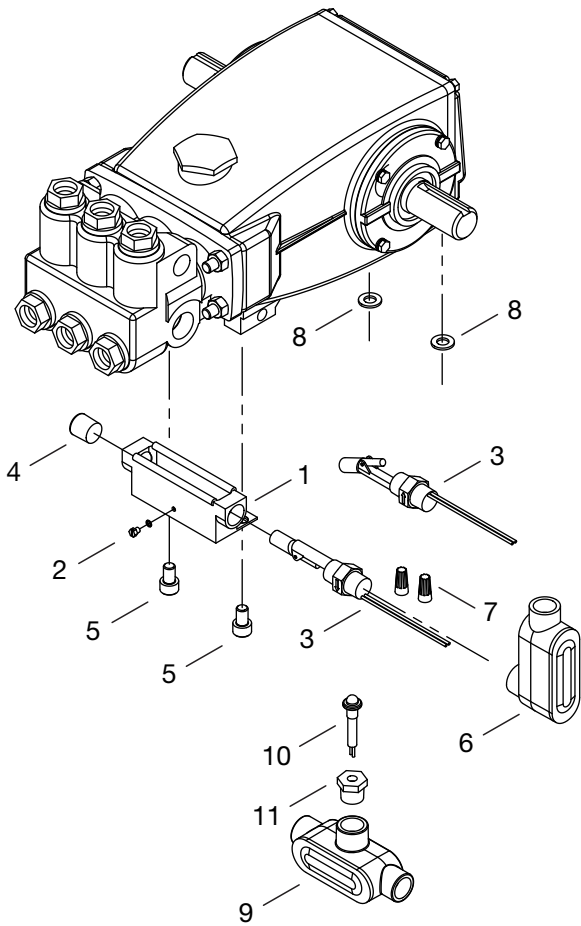

For model 30664

ITEM	PN	MTL	DESCRIPTION	QTY
1	—	AL	Pan, Leak w/edging	1
2	—	BBNP	Plug (#10-32) w/NBR gasket	1
3	30216	POP	Switch, Float	1
4	—	BB	Plug, Inlet (1/2"NPTM)	1
5	30162	STL	Screw, HSH (M10 x 16)	2
6	—	AL	Box, Junction Elbow (1/2"NPTF)	1
7	—	—	Wire-nut, Orange (600V)	2
8	126574	STZP R	Washer, Flat (M10)	2

For model 30664.120AC

9	—	AL	Box, Junction, Tee (1/2"NPTF)	1
10	30596	—	Light, Amber, 120VAC	1
11	—	BB	Bushing, (1/2"NPTM x 3/8"-24UNF)	1

MATERIAL CODES (Not part of part number): AL = Aluminum, BB = Brass, BBNP = Brass/Nickel Plated, POP = Polypropylene, STL = Steel, STZP = Steel/Zinc Plated. R components comply with RoHS Directive

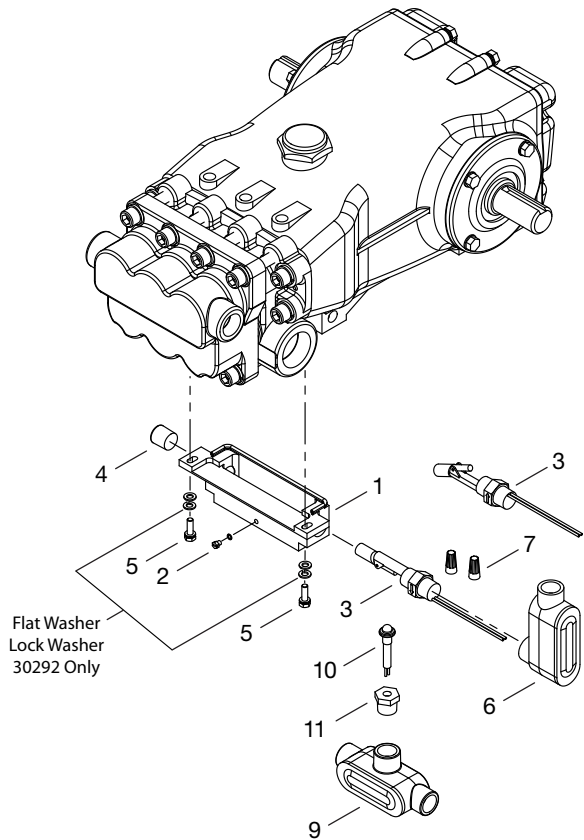

For models 30290, 30292

ITEM	PN	MTL	DESCRIPTION	QTY
1	—	AL	Pan, Leak w/edging	1
2	—	BBNP	Plug (#10-32) w/NBR gasket (30290)	1
	—	S	Screw (#10-32) w/Silicone Gasket (30292)	1
3	30216	POP	Switch, Float	1
4	—	BB	Plug, Inlet (1/2"NPTM) (30290)	1
	—	S	Plug, Inlet (1/2"NPTM) (30292)	1
5	92520	STZP	Screw, HHC SEMS (M6 x 20) (30290)	2
	36179	SS	Screw, HH (M6 x 25) (30292)	2
	36488	SS	Washer, Flat (30292)	2
	15849	SS	Washer, Lock (30292)	2
6	—	AL	Box, Junction Elbow (1/2"NPTF)	1
7	—	—	Wire-nut, Orange (600V)	2

For model 30290.120AC

9	—	AL	Box, Junction, Tee (1/2"NPTF)	1
10	30596	—	Light, Amber, 120VAC	1
11	—	BB	Bushing, (1/2"NPTM x 3/8"-24UNF)	1

MATERIAL CODES (Not part of part number): AL = Aluminum, BB = Brass, BBNP = Brass/Nickel Plated, POP = Polypropylene, S= 304 Stainless Steel, SS=316 Stainless Steel, STZP = Steel/Zinc Plated.

OPERATION

This LPS monitor is designed to collect water in a leak pan after water leaks past the low pressure seals. Leakage can be monitored either by PLC or PC interface, or by an indicator light. The float switch located in the leak pan can be configured in a normally closed (NC) with arrow facing down or normally open (NO) position with arrow facing up.

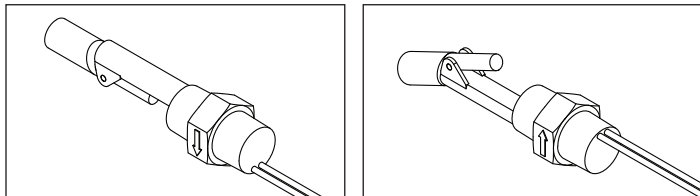

Normally Closed

Normally Open

We recommend a normally closed configuration when using the indicator light option. The light will remain on. When the light goes out, seals need to be replaced in the pump and/or the light is burnt out.

ASSEMBLY OF LPS MONITOR

All four versions of the LPS monitors require assembly before being installed on the pump.

1. Apply thread sealant or PTFE thread tape on threads of inlet plug (Item 4). Thread 1/2" NPTM inlet plug into either port of leak pan that meets your existing mounting configuration. Ensure black edging is positioned on top surfaces of leak pan.
2. Thread #10-32 drain plug (Item 2) with gasket into small hole on side of leak pan (Item 1).
3. Apply PTFE thread tape on threads of each end of float switch (Item 3). Thread float switch into open end of leak pan (Item 1) and tighten. Position arrow on hex nut body so it faces down. This is the normally closed position. Positioning the arrow up is normally open.
4. On PLC/PC units, remove side cover with screws from junction elbow box (Item 6). String loose end of wires from float switch (Item 3) through junction elbow box (Item 6). Thread junction box onto threads of float switch (Item 3) and tighten. Ensure arrows on hex nut body are still facing down. String loose end of wires from PLC/PC through other port of box. Cut wires to size and wire nut together. Reposition cover and tighten screws.
5. On non-PLC/PC units (with lights), remove side cover with screws from junction tee box (Item 9). String loose end of wires from float switch (Item 3) through junction tee box (Item 9). Thread junction box onto threads of float switch (Item 3) and tighten with cover facing pump manifold. Ensure arrows on hex nut body are still facing down. Thread 1/2" NPTM bushing (Item 11) into junction tee box (Item 9). Thread amber light (Item 10) into bushing and hand tighten. Cut wires to size. Wire nut one end of amber light lead to float switch and the other to the power lead. Reposition cover and tighten screws.

INSTALLATION OF ASSEMBLED UNITS

Use 30664 and 30664.120AC for pump models:

650, 651, 660, 661, 661C, 661D, 681, 681K, 1050, 1051, 1051C, 1051D, 1057, 1530, 1531, 1540, 1540E, 1541, 1560, 1810, 1810K, 1851, 1851K, 1861, 1861K.

1. Pump mounted on rails — remove pump from rails. Do not remove pump oil pan. Position LPS monitor so leak pan opening is facing up and mounting holes line up with direct mounting tapped holes on bottom of pump. Thread in two screws (as supplied) (Item 5) and tighten. Reassemble pump to rails by using the first set of holes on rails.

2. Pump mounted on flat base (no rails) — remove mounting bolts. Do not remove pump oil pan. Position LPS monitor so leak pan opening is facing up and mounting holes line up with direct mounting holes on flat base. Place two washers (as supplied) (Item 8) on flat base at the two rear holes directly under pump. These washers will keep the pump level. Position pump over hole pattern on flat base. Tighten to flat base with existing bolts (Do not use screws as supplied).

Seal retainers must be retrofitted in order to use this LPS monitor for the pump models:

1520, 1521, 2510, 2511, 2520, 2520C, 2521, 2530, 2530E, 2531, 2537, 2831 and 2831K (Note: Contact Cat Pumps to order modified seal retainer part numbers: 49788 and 49789).

Follow the instructions below to modify your current seal retainers if S/N is prior to 3/11:

1. Remove pump from rails or flat base (no rails).
2. Remove discharge and inlet manifolds from pump.
3. Remove seal retainers from each piston/plunger rod.
4. Ensure rear seal retainer (sleeve) is inside of seal retainer and ends are flush for all plunger pump models.
5. Measure 5/8" from non stepped end and drill 3/8" diameter hole through one wall only of seal retainer.
6. Reinstall seal retainer on each piston/plunger rod with new hole facing down and towards the crankcase. New hole should line up directly over detector pan.
7. Reinstall inlet and discharge manifolds.

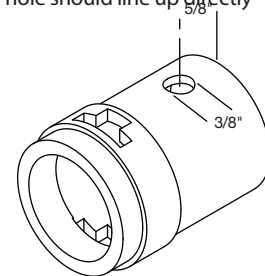

Use 30290, 30290.120AC and 30292 for pump models:

1520, 1521, 2510, 2511, 2520, 2520C, 2521, 2530, 2530E, 2531, 2537, 2831, 2831K, 3501, 3501C, 3507, 3507C, 3511, 3511C, 3517, 3517C, 3520, 3520C, 3521, 3521C, 3527, 3531, 3531C, 3535, 3535C, 3537, 3541, 3541C, 3545, 3560, 3801, 3801K, 3811, 3811K, 3821, 3821K, 3831, 3831K, 3841, 3841K.

1. Pump mounted on rails — Remove screws and pump oil pan. Position LPS monitor so leak pan opening is facing up and machined shelf surface is facing towards the manifold. Slide pump oil pan into machined area of LPS monitor. Align slotted mounting holes of monitor with mounting holes of oil pan. Thread in two screws as supplied (Item 5) while pushing monitor towards drive end so it contacts crankcase and tighten. Note: On model 30292 add lockwasher and flatwasher.
2. Pump mounted on flat base (no rails) — Remove screws and pump oil pan. Position LPS monitor so leak pan opening is facing up and machined shelf surface is facing towards the manifold. Slide oil pan into machined area of LPS monitor. Align slotted mounting holes of monitor with mounting holes for oil pan. Thread in two screws as supplied (Item 5) while pushing monitor towards drive end so it contacts crankcase and tighten. Note: On model 30292 add lockwasher and flatwasher.

MAINTENANCE

- Remove water from leak pan by removing drain plug (Item 2).
- Periodically inspect for leaks around brass plug (Item 4), drain plug (Item 2) and float switch (Item 3).
- Inspect wiring from float switch (Item 3) and junction box (Items 6 or 9).

TROUBLESHOOTING

Problem	Probable Cause	Solution
Indicator light is out	Power is out, low pressure seals worn and/or light bulb burnt out.	Turn on power, replace seals and/or light.
Leaking	Worn drain plug o-ring, brass plug is loose, or float switch threaded incorrectly.	Replace o-ring, tighten plug, or reposition and use thread tape.



CAT PUMPS

1681 - 94TH LANE N.E. MINNEAPOLIS, MN 55449-4324
PHONE (763) 780-5440 — FAX (763) 780-2958
e-mail: techsupport@catpumps.com
www.catpumps.com