

DATA SHEET

INDUSTRIAL CLUTCHES



25 Frame Plunger Pumps:

30655

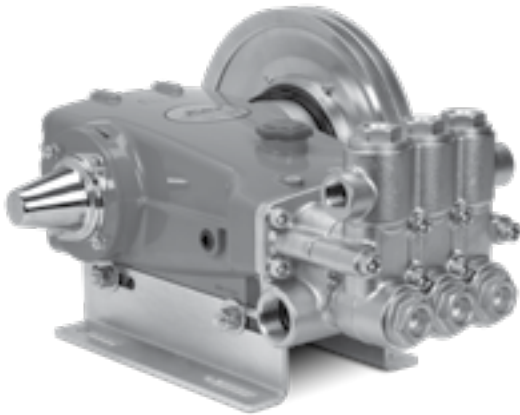

Pump Model 2510 shown (pump and rails sold separately)

SELECTION

Select the clutch to match the pump shaft size and belt horsepower rating.

INSTALLATION

1. Remove the four bearing cover screws on pump and discard.
2. Using spacer as an alignment tool, slide large diameter end of spacer first over shaft of pump. Install clutch plate over spacer until flush against crankcase. Ensure countersunk holes of clutch plate line up with bearing cover screw holes. Secure with four countersunk head screws (M10) and lockwashers (M10) and torque per specifications. **Do not use pump bearing cover screws.**
3. Remove spacer from crankshaft. Reverse the position of the spacer so that small diameter end now faces the pump.
4. Mount the coil assembly onto the clutch plate and secure with three flanged screws and torque evenly per specifications.
5. Lubricate the pump shaft with antiseize lubricant.
6. Place clutch assembly on work surface with visible bearing facing up.
7. Position pulley on clutch assembly with concave up. On dual grooves, place second pulley with concave down.
8. Line up the six pulley holes with six clutch assembly holes. Secure with six socket head cap screws and torque per specifications.
9. Slide the Clutch/Pulley assembly over shaft. Be certain keyway of pump is aligned with armature keyway and insert the key into the pump shaft. Secure with flat washer and shaft screw (M10x25) and torque per specifications.

FEATURES

- Special e-coating offers 3 to 6 times better corrosion resistant finish.
- Special bearings with unique grease offer more consistent viscosity at high temperatures and better water resistance for harsh environments.
- Special projection welded coil and plate offers extra durability in heavy vibration applications.
- Superior strength forged rotor, hub and armature offer superior flux and maximum torque for long life.

SPECIFICATIONS

	U.S.	Metric
Pump Frame	25 Frame	25 Frame
Pulley Grooves	2	2
Shaft Diameter	1.181"	30 mm
Pitch Diameter	12.4"	315 mm
Belt Type	B	B
Torque*	100 ft./lbs.	135 Nm
Watts	50	50
Amps	4.2	4.2
Power Required	12 VDC	12 VDC
Weight	22 lbs.	9.9 kg
Dimensions	2.45 x 12.75"	62 x 324 mm

$$\text{*Hydraulic Torque (ft. lbs.) Required} = 3.6 \times \frac{\text{gpm} \times \text{psi}}{\text{rpm}}$$

10. Connect the lead wire to the positive side of the electric circuit. Also be certain there is an adequate grounded connection to the coil assembly plate.
11. Engage and disengage the clutch to assure proper functioning. If full load is required initially from the pump, allow clutch to engage 20-50 cycles before commencing normal operation for adequate burnishing.

NOTE: Follow standard belt mounting and center distance procedures to determine drive pulley size, speed and horsepower per belt.

OPERATION

The clutch works with a flow switch, pressure switch or a manual on/off switch installed in the system and connected to a 12VDC power supply. When the trigger gun is released or the unit is manually turned off, a signal is sent to the clutch to disengage and cease pump operation. When operation resumes by opening the trigger gun or manually turning the system on, the clutch will engage, starting the pump and resuming full operation.

PARTS LIST

ITEM	MATL	DESCRIPTION	QTY
1	STZP	Screw, Shaft, HH	1
2	STZP	Washer, Flat (M10)	1
3	—	Armature	1
4	—	Rotor	1
5	—	Ring, Snap	1
6	STZP	Screw, Flanged Coil Assembly	3
7	—	Assembly, Coil	1
8	AL	Plate, Clutch	1
9	S	Screw, FH (M8x40)	4
10	STL	Key (M8x6.35x40)	1
11	STZP	Pulley, "B" (12.4") - Not Shown	2
12	S	Lockwasher	4
13	AL	Spacer	1
14	—	Lubricant, Antiseize - Not Shown	1

Material Codes (Not Part of Part No.):

AL=Aluminum S=304SS STL=Steel STZP=Steel/Zinc Plated

EXPLODED VIEW

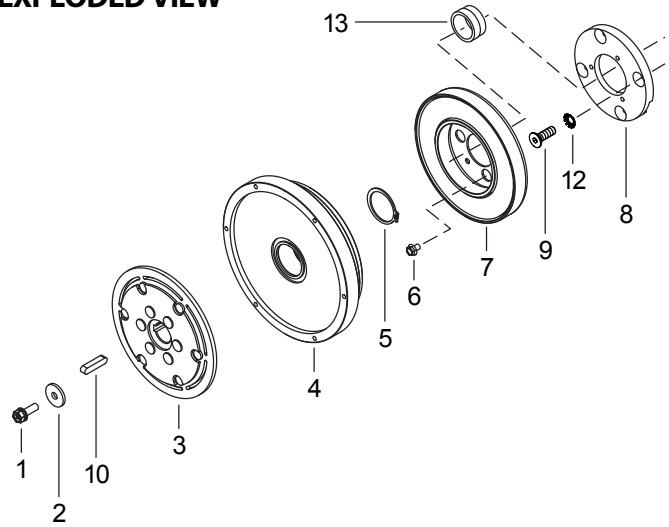

TORQUE REQUIREMENTS

Item	Thread Size	Tool Size	in. lbs.	Torque ft. lbs.	Nm
Plate Screws	M8	M5 Allen	115	9.58	13.0
Coil Assembly Screws	1/4"	3/8" Hex	55	4.6	6.2
Shaft Screw	M10	M17 Hex	220	18.0	24.0
Hub/Pulley Screws	1/4"	3/16" Allen	55	4.4	6.2

TROUBLESHOOTING

Clutch will not engage.	<ul style="list-style-type: none"> • Check positive and ground connections. • Check for 12 VDC.
Squealing belt(s).	<ul style="list-style-type: none"> • Check belt slippage or belt tension.
Short belt life.	<ul style="list-style-type: none"> • Check side-to-side alignment and belt tension.
Excessive noise when clutch disengaged.	<ul style="list-style-type: none"> • Worn bearing; replace clutch assembly.
Clutch cycling.	<ul style="list-style-type: none"> • Check for adequate voltage. • Worn rotor or discolored rotor surface; replace clutch assembly.
Scraping noise when clutch engaged and/or disengaged.	<ul style="list-style-type: none"> • Check alignment of coil and rotor assembly.

DIMENSIONAL

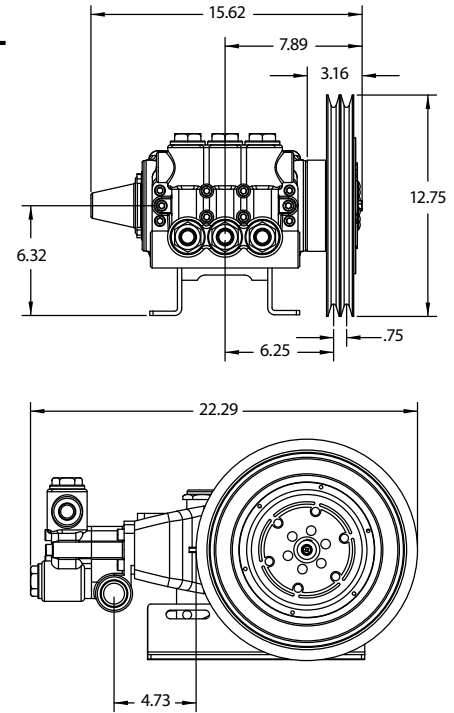

⚠ CAUTIONS AND WARNINGS

All High Pressure Systems require a primary pressure regulating device (i.e. regulator, unloader) and a secondary pressure relief device (i.e. pop-off valve, relief valve). Failure to install such relief devices could result in personal injury or damage to pump or property. Cat Pumps does not assume any liability or responsibility for the operation of a customer's high pressure system.

Read all CAUTIONS and WARNINGS before commencing service or operation of any high pressure system. The CAUTIONS and WARNINGS are included in each service manual and with each Accessory Data sheet. CAUTIONS and WARNINGS can also be viewed online at www.catpumps.com/cautions-warnings or can be requested directly from Cat Pumps.

WARRANTY

View the Limited Warranty on-line at www.catpumps.com/warranty.



CAT PUMPS

1681 - 94TH LANE N.E. MINNEAPOLIS, MN 55449-4324
 PHONE (763) 780-5440 — FAX (763) 780-2958
 e-mail: techsupport@catpumps.com
www.catpumps.com