

DATA SHEET

RELIEF VALVES



The Pumps with Nine Lives

**Stainless Steel
Models:**

**890700, 890702, 890704, 890706, 890709,
890718, 890720, 890731**



FEATURES

- 316 Stainless Steel bodies.
- FPM seals and o-rings.
- Maximum temperature 300° F (149° C)

COMMON

SPECIFICATIONS

	U.S.	Metric
Inlet/Outlet Port – Female	2" NPT	2" NPT
By-Pass Port – Male	2" NPT	2" NPT

SPECIFICATIONS	U.S. Measure	Metric Measure
----------------	--------------	----------------

890700		
Flow Range	30 - 180 gpm	114 - 681 lpm
System Pressure Range	1000 - 3000 psi	69 - 207 bar
Maximum Relief Setting	3750 psi	258 bar
Weight	22.75 lbs.	10.30 kg
Dimensions	12.73 x 5.25"	323 x 133 mm

890702		
Flow Range	25 - 210 gpm	95 - 795 lpm
System Pressure Range	500 - 2000 psi	34 - 138 bar
Maximum Relief Setting	2500 psi	172 bar
Weight	22.75 lbs.	10.30 kg
Dimensions	12.73 x 5.25"	323 x 133 mm

890704		
Flow Range	45 - 320 gpm	170 - 1211 lpm
System Pressure Range	500 - 2000psi	34 - 138 bar
Maximum Relief Setting	2500 psi	172 bar
Weight	28.75 lbs.	13.04 kg
Dimensions	17.91 x 5.25"	455 x 133 mm

890706		
Flow Range	15 - 260 gpm	56 - 984 lpm
System Pressure Range	250 - 1000 psi	17 - 69 bar
Maximum Relief Setting	1250 psi	86 bar
Weight	28.75 lbs.	13.04 kg
Dimensions	17.91 x 5.25"	455 x 133 mm

SPECIFICATIONS	U.S. Measure	Metric Measure
----------------	--------------	----------------

890709, 890720		
Flow Range	20 - 60 gpm	76 - 227 lpm
System Pressure Range	1500 - 4000 psi	103 - 276 bar
Maximum Relief Setting	5000 psi	345 bar
Weight	22.75 lbs.	10.30 kg
Dimensions	12.73 x 5.25"	323 x 133 mm

890718		
Flow Range	10 - 50 gpm	38 - 189 lpm
System Pressure Range	1000 - 8000 psi	69 - 552 bar
Maximum Relief Setting	10000 psi	689 bar
Weight	22.75 lbs.	10.30 kg
Dimensions	12.73 x 5.25"	323 x 133 mm

890731		
Flow Range	15 - 75 gpm	56 - 284 lpm
System Pressure Range	100 - 400 psi	7 - 28 bar
Maximum Relief Setting	500 psi	34 bar
Weight	22.75 lbs.	10.30 kg
Dimensions	12.75 x 6.12"	323 x 155 mm

PARTS LIST

ITEM NO.	DESCRIPTION	MTL	QTY	890700	890702	890704	890706	890709	890718	890720	890731
402	Screw, Adjustment	SS	1	890861	890861	890860	890860	890861	890861	890861	890861
403	Nut, Locking	SS	1	890871	890871	890871	890871	890871	890871	890871	890871
408	Washer, Spring	STZP	(*)	890836 (18)	890836 (18)	890836 (42)	890836 (36)	890836 (20)	890836 (18)	890836 (20)	890858 (19)
412	Assembly, Piston	SS	1	890830	890830	890831	890831	890830	890830	890830	890830
414	Backup-Ring, Piston	PTFE	1	—	—	—	—	—	—	—	—
415	Piston Seal, Quad Ring	FPM	1	—	—	—	—	—	—	—	—
418	Stem, Shock	S	1	890740	890740	890741	890741	890740	890740	890740	890740
419	O-Ring, Shock Stem	FPM	2	—	—	—	—	—	—	—	—
420	Plug, Shock Stem	SS	1	890889	890889	890889	890889	890889	890889	890889	890889
425	Cap, Body	SS	1	890851	890851	890852	890852	890851	890851	890851	890851
436	Seat	SS	1	—	—	—	—	—	—	—	—
437	O-Ring, Seat	FPM	1	—	—	—	—	—	—	—	—
438	Spacer, Seat	SS	1	NA	NA	890829	890829	NA	NA	NA	NA
440	Body	SS	1	890801	890801	890802	890802	890801	890801	890801	890801
455	Fitting, By-Pass (2" NPT)	SS	1	890810	890810	890808	890808	890810	890809	890810	890810
468	Kit, Repair (Incls: 414,415,419)	FPM	1	—	—	890742	890742	—	—	—	—

(*) = See individual quantity

It is recommended to replace spring washers as a set.

Material Codes (Not Part of Part Number): FPM = Fluorocarbon, PTFE = Pure Polytetrafluoroethylene, S = 304SS, SS = 316SS, STZP = Steel/Zinc Plated

TYPICAL INSTALLATION

1. Triplex Plunger Pump

2. Pulsation Dampener

3. Relief Valve

4. Pop-off Valve (Shown as Secondary Relief Valve)

5. Pressure Gauge

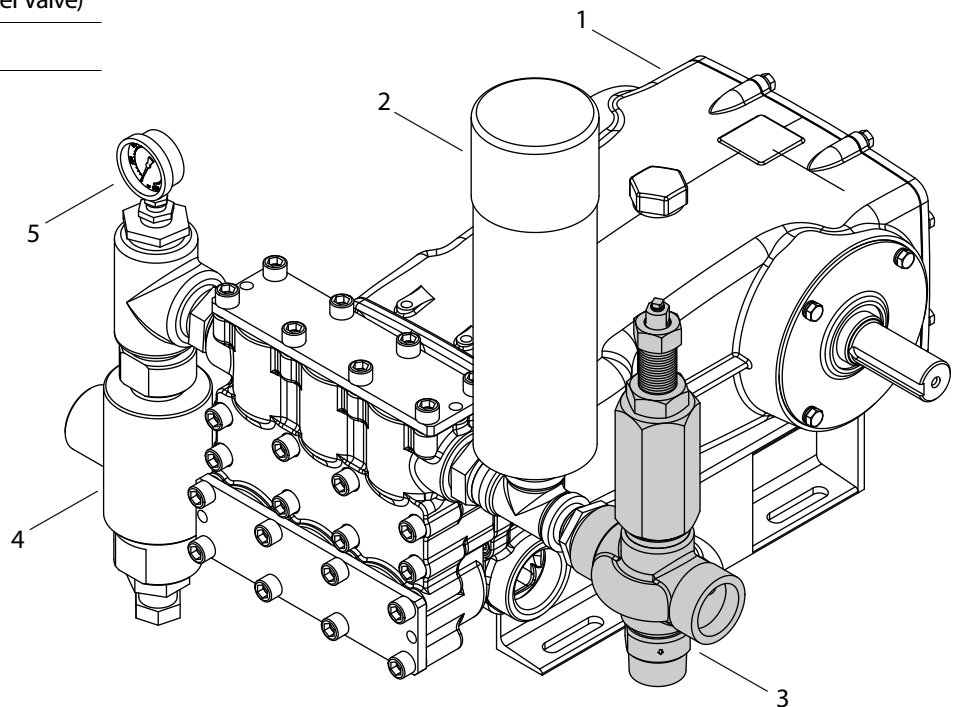

EXPLODED VIEW

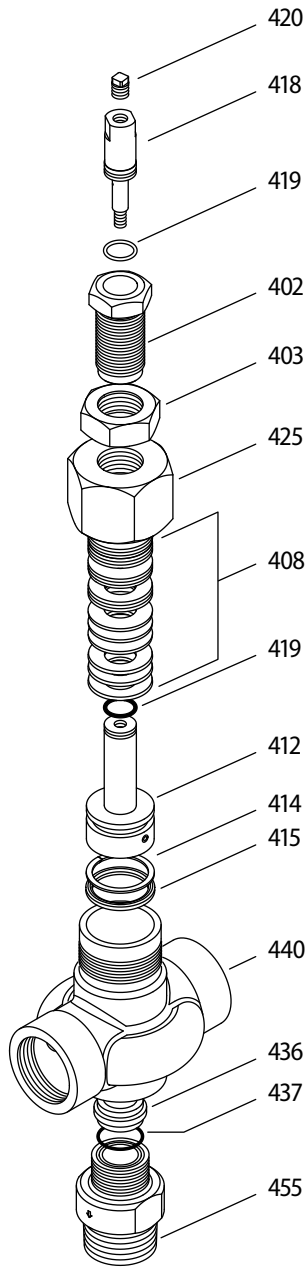

PLUMBING VIEWS

MODELS

890700, 890702, 890704,
890706, 890709, 890720,
890731

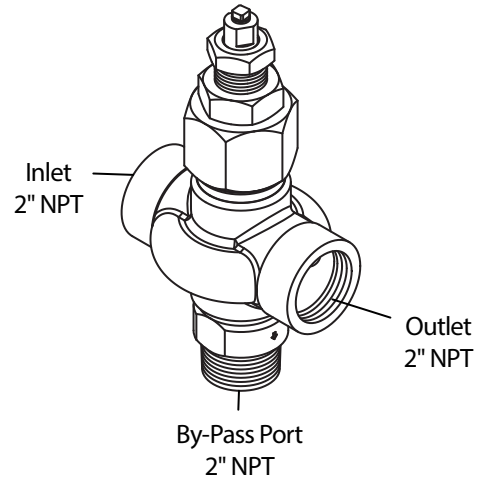

MODEL

890718

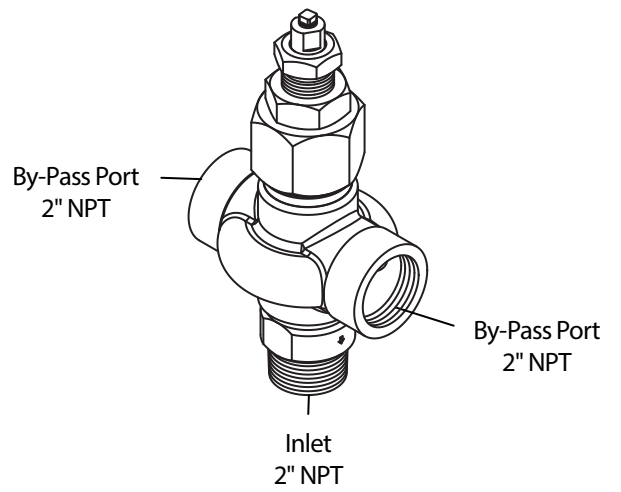

Read all CAUTIONS and WARNINGS before commencing service or operation of any high-pressure system

SELECTION

This valve is to be used as a secondary pressure relief. The relief valve should meet the desired system flow and pressure requirements.

INSTALLATION

The relief valve should be mounted at the discharge manifold between the primary regulating device and the pump and before any other accessories in the system.

NOTE: The relief valve is a secondary safety device. It does not replace a pressure regulator or unloader.

The inlet port and by-pass ports are marked with arrows indicating the direction of the flow. The by-pass liquid that is directed out can be routed to a reservoir (perferred method) or to a drain or to the pump inlet. The model **890718** has (2) by-pass ports.

Plug one and use the other for by-pass line.

OPERATION

The primary function of this relief valve is to relieve system pressure and by-pass pumped liquid in the event the primary valve should fail. If the primary valve fails to by-pass at set system pressure, this secondary relief valve will open and allow the liquid to by-pass.

PRESSURE ADJUSTMENT

Setting The Primary Pressure Regulating Device.

1. Setting and adjusting the primary pressure regulator device and relief valve must be done with the system "ON".
2. Start the system with the primary pressure regulating device backed off to the lowest pressure setting (counter clockwise direction) and the relief valve set at the highest pressure setting (clockwise direction).
3. Adjust the primary device in small increments by turning the nut in a clockwise direction.
4. Repeat this process until desired system pressure is attained.

Setting The Relief Valve.

1. Turn adjusting screw (Item #420) on the top of the relief valve in a counterclockwise direction in small increments until there is some visible liquid coming out of the by-pass port.
2. Turn adjusting screw (Item #420) on the top of the relief valve in a clockwise direction until visible liquid stops coming out.
3. Final adjustment for the relief valve should relieve at 200 psi above the system operating pressure.x

TROUBLESHOOTING

Valve chatters or cycles	<ul style="list-style-type: none">• Valve is improperly set. Repeat adjustment procedure.• Air in system. Check connections
Valve continually by-passes	<ul style="list-style-type: none">• Seat, ball or piston stem is worn. Replace as needed.• O-Ring seat damaged. Replace as needed.
Leaking out the top of valve	<ul style="list-style-type: none">• O-Rings on piston stem worn or cut. Replace as needed.
Pressure Spikes	<ul style="list-style-type: none">• Spring compressed.• Restricted by-pass or no by-pass.

⚠ CAUTIONS AND WARNINGS

All High Pressure Systems require a primary pressure regulating device (i.e. regulator, unloader) and a secondary pressure relief device (i.e. pop-off valve, relief valve). Failure to install such relief devices could result in personal injury or damage to pump or property. Cat Pumps does not assume any liability or responsibility for the operation of a customer's high pressure system.

Read all CAUTIONS and WARNINGS before commencing service or operation of any high pressure system. The CAUTIONS and WARNINGS are included in each service manual and with each Accessory Data sheet. CAUTIONS and WARNINGS can also be viewed online at www.catpumps.com/cautions-warnings or can be requested directly from Cat Pumps.

WARRANTY

View the Limited Warranty on-line at www.catpumps.com/warranty.



CAT PUMPS

1681 - 94TH LANE N.E. MINNEAPOLIS, MN 55449-4324
PHONE (763) 780-5440 — FAX (763) 780-2958
e-mail: techsupport@catpumps.com
www.catpumps.com