

MODEL 4SP21EL PLUNGER PUMP

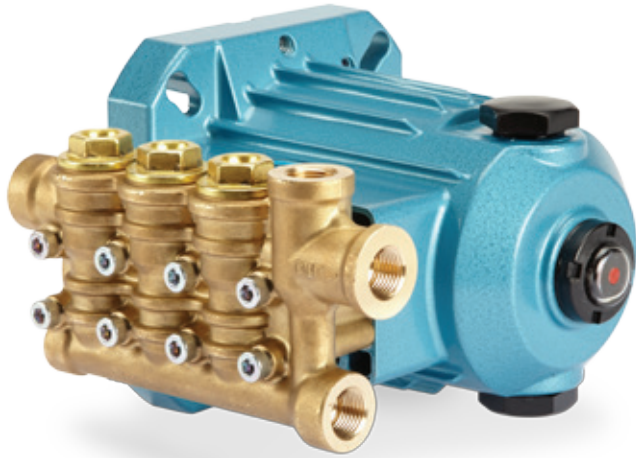

2.1 GPM – 2,000 PSI

Compact Direct Drive Pump with Long-Lasting Seals

When it comes to getting the job done, customers rely on durable long-lasting products from Cat Pumps and the 4SP is no exception. Designed for continuous duty applications, the 4SP series pumps are built to the same high standards as all Cat Pumps products. Every design detail has been optimized for exceptional performance and long-life.

Compact in size, the 4SP series pumps is not short on features that translate into dependable service:

- Specially formulated high-pressure seals and concentric, polished ceramic plungers provide maximum seal life, keeping equipment running longer with less downtime.
- Compact, hollow shaft pump for direct mounting eliminates the need for pulleys, belts or gearboxes.
- Stacked valve design makes service even easier

Cat Pumps products are designed to keep equipment running longer. Nothing outruns, outlasts, or outperforms Cat Pumps products.

Features

- Discharge porting options (2 horizontal and 1 vertical) for neater and easier plumbing
- Crankcase can be vented (for misting or other applications) or completely sealed (for portable extractors) — making the 4SP a perfect fit for multiple applications
- Direct drive hollow shaft mounts to standard 56C frame electric motors for convenient and worldwide use

Typical Applications

- Portable extractors for professional cleaning
- Misting and fogging for cooling
- Humidification
- Pressure washing

Specifications

	US Measure	Metric Measure
Flow	2.1 gpm	7.9 lpm
Pressure	100 to 2,000 psi	7 to 140 bar
RPM	1750 rpm	1750 rpm
Shaft Diameter	5/8"	15.9 mm
Inlet Pressure Range	Tank fed to 60 psi	Tank fed to 4 bar
Max. Liquid Temperature	140° F	60° C
Inlet Port (1)	3/8" NPT(F)	3/8" NPT(F)
Accessory Inlet Port (1)	1/4" NPT(F)	1/4" NPT(F)
Discharge Ports (3)	3/8" NPT(F)	3/8" NPT(F)
Weight	10.6 lbs	4.8 kg
Dimensions	7.8 x 6.7 x 5.3"	198 x 171.5 x 134 mm

Note: Direct-drive hollow shaft mounts to a standard 56C motor.

Dimensions

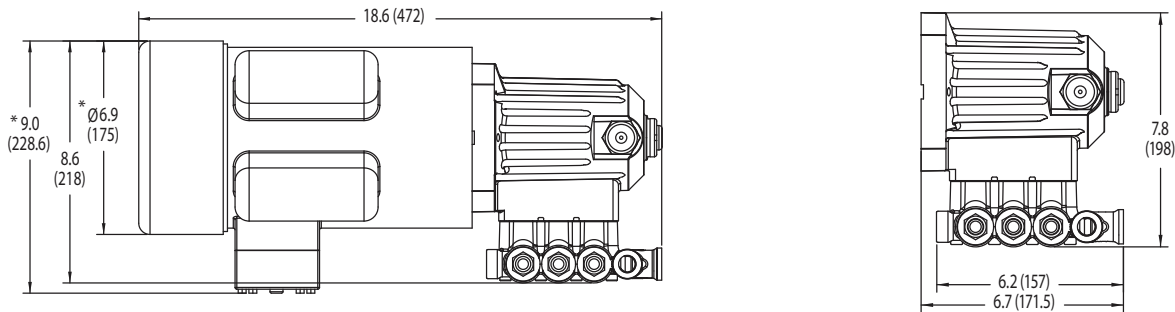

* Dimensions with 8060 motor

Popular Accessories



Unloader
PN 7583
0.5 – 8.0 gpm
250 – 2,000 psi



Pop-Off Valve
PN 30961
1 – 6 gpm
1,000 – 3,000 psi



Pressure Gauge
PN 6088
0 – 3,000 psi



Inlet Strainer
PN 7204.4
1/2" NPT(F)
10 gpm Max



Oil
PN 6107
21 oz. Bottle
Specially Formulated for
Extended Protection

Contact Cat Pumps for pricing or more information at techsupport@catpumps.com or 763-780-5440



CAT PUMPS

1681 - 94TH LANE N.E. MINNEAPOLIS, MN 55449-4324
PHONE (763) 780-5440 — FAX (763) 780-2958
e-mail: techsupport@catpumps.com
www.catpumps.com

For International Inquiries go to www.catpumps.com and navigate to the "Contact Us" link.

©2014 Cat Pumps All rights reserved. 993489 Rev. A 3/14