

# MODEL 3570 PLUNGER PUMP

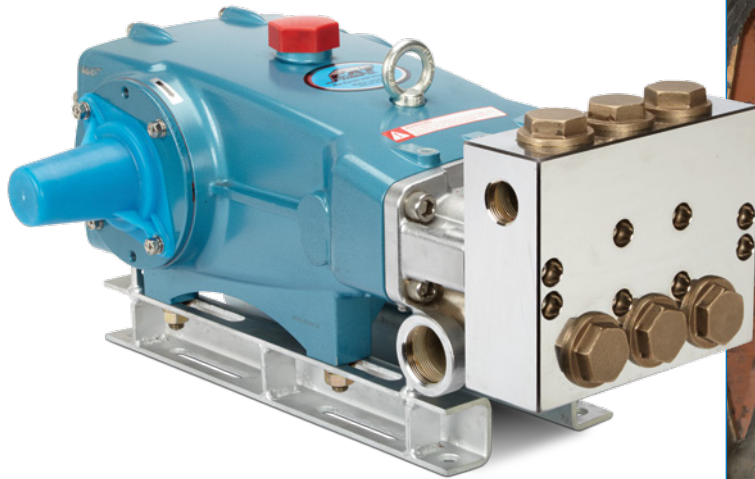

30 GPM – 3,000 PSI

## Designed for Jetting and Hydroexcavating Applications

Cat Pumps model 3570 is the ideal combination of high flow and high pressure, rated to 30 gpm/114 lpm and 3,000 psi/207 bar. Higher flow rates are desirable for jetting and other cleaning applications, where the 3,000 psi helps remove the most stubborn contamination. The 3570 is the perfect pump for demanding applications requiring dependable intermittent performance.

Cat Pumps engineers have optimized every detail to produce a dependable pump with excellent service life. Concentric, high-density polished solid plungers provide a true wear surface that results in long seal life. The drive-end uses matched connecting rods and oversized bearings to provide many hours of trouble-free service. The 3570 is what you expect from Cat Pumps — high quality, dependable products backed by the industry's best customer service and support.

### Features:

- V-Packings and Lo-Pressure seals are completely lubricated and cooled, greatly increasing service life.
- High-pressure manifold is easily serviced without entering crankcase, reducing field service time.
- Oversized crankshaft bearings with greater loading capacity provide longer bearing life.
- Brass chrome-plated manifolds for added strength and corrosion resistance.

### Typical Applications:

- Water Jetting
- Hydro Excavation
- Surface Preparation
- Central Cleaning Systems
- High-Flow/Pressure Flushing
- Blowout Preventer (BOP) Charging

## Specifications

	US Measure	Metric Measure
<b>Flow*</b>	30 gpm	114 lpm
<b>Pressure*</b>	3,000 psi	207 bar
<b>RPM</b>	1080 rpm	1080 rpm
<b>Inlet Pressure Range</b>	Flooded to 70 psi	Flooded to 4.8 bar
<b>Max Liquid Temperature</b>	120°F	48°C
<b>Inlet Ports (2)</b>	1 1/2" NPT(F)	1 1/2" NPT(F)
<b>Discharge Ports (2)</b>	1" NPT(F)	1" NPT(F)
<b>Weight</b>	138.9 lbs	63 kg
<b>Dimensions</b>	23.94 x 18.11 x 9.72"	608 x 460 x 247 mm

\*Intermittent Duty Only – operating pump at stated flow and pressure for no more than 50% of time in any given hour.

## Dimensions

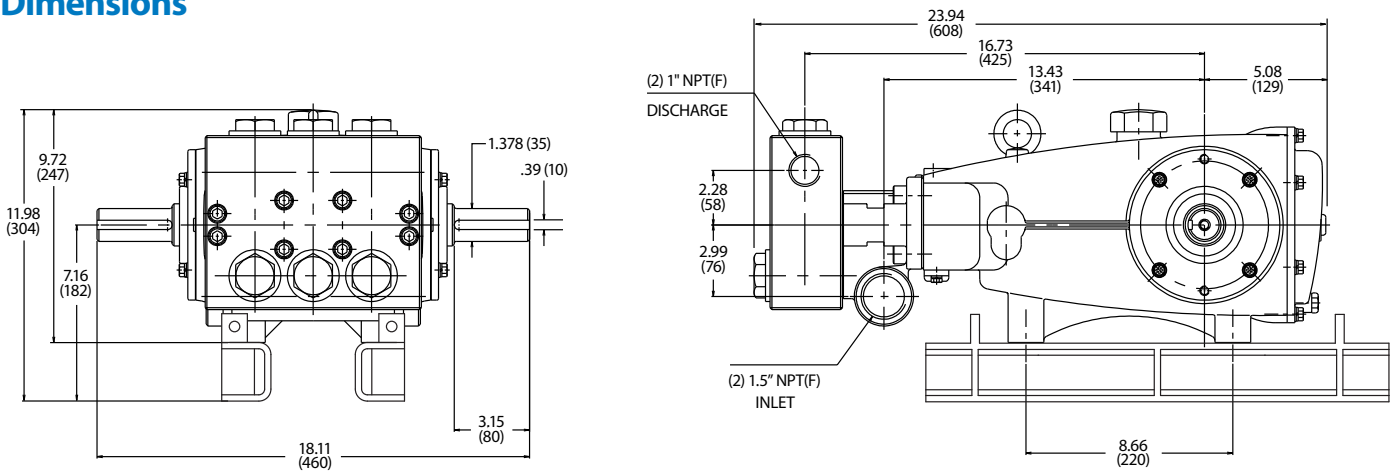

## Popular Accessories



### Pressure Regulator

PN 7033  
3.5 – 35 GPM  
1,500 – 3,000 PSI



### Pop-off Valve

PN 890711  
0 – 50 GPM  
1,000 – 6,000 PSI



### Pressure Gauge

PN 6089  
0 – 6,000 PSI



### Pulsation Dampner

PN 701503  
75 GPM Max  
100 – 3,000 PSI



### Oil

PN 6107  
21 oz. Bottle  
Specially Formulated for  
Extended Protection

Contact Cat Pumps for more information at [info@catpumps.com](mailto:info@catpumps.com) or 763-780-5440



### CAT PUMPS

1681 - 94TH LANE N.E. MINNEAPOLIS, MN 55449-4324  
PHONE (763) 780-5440 — FAX (763) 780-2958  
e-mail: [techsupport@catpumps.com](mailto:techsupport@catpumps.com)  
[www.catpumps.com](http://www.catpumps.com)