

MODEL 56HS PLUNGER PUMP

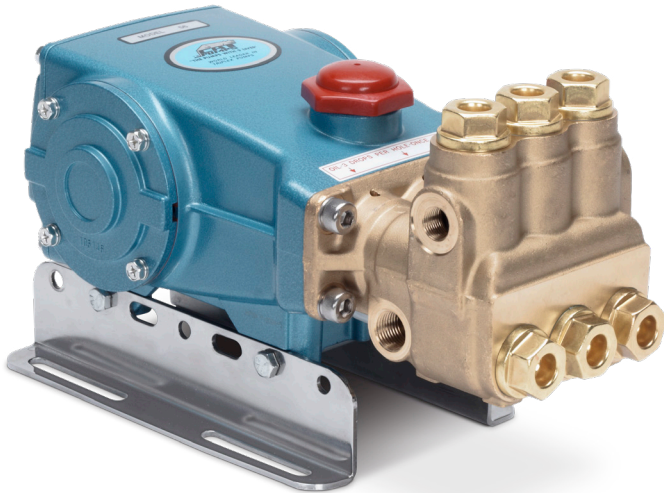

8.0 GPM | 3,000 PSI

Designed for Demanding High-Pressure Applications

When quality counts, Cat Pumps is the #1 choice for high-pressure applications. Don't fall into the price trap by choosing a less expensive pump up front that will end up costing more in the long run. Get more work done without the hassles and downtime — choose Cat Pumps.

Cat Pumps engineers have optimized every detail to produce a dependable pump with excellent service life. Concentric, high-density polished solid plungers provide a true wear surface that results in long seal life. The drive-end uses matched connecting rods and oversized bearings to provide many hours of trouble-free service. The 56HS is what you expect from Cat Pumps — high quality, dependable products backed by the industry's best customer service and support.

Typical Applications:

- Water Jetting
- Hydro Excavation
- Pressure Washing
- Wash Down
- Surface Preparation

Features

- High and low-pressure seals are completely lubricated and cooled, greatly increasing pump life
- Flexible Drive options
 - Electric Motor
 - Belt with standard pulley or clutch
 - Direct-drive with bell housing and flex coupler
 - Gas or Diesel Engine
 - Belt with standard pulley or clutch
 - Gearbox for 1" or 1 1/8" engine shafts
 - Hydraulic Motor
 - Direct Drive with bell housing and flex coupler

56HS Drive Options

Model 56HS is easily configurable to any application. From gasoline-driven pressure washers to hydraulic-driven pumps used on hydro excavation trucks to electric-driven units in a food production facility, and everything in between.



Bell Housing with Electric Motor
Bell Housings available for NEMA and IEC electric motors



Bell Housing with Hydraulic Motor
Bell Housings available for SAE (A and B) Hydraulic Motors



Gear Box with Gas or Diesel Engine
Gearboxes available for 1" or 1 1/8" shafts



Pulley with Belt Drive
Pulley-driven allows flexibility for motor or engine driven options

Specifications

	U.S. Measure	Metric Measure
Flow	8.0 gpm	30.3 lpm
Pressure	3000 psi	207 bar
Pump RPM*	1760 rpm	1760 rpm
Inlet Pressure Range	Flooded to 60 psi	Flooded to 4.1 bar
Max Liquid Temperature	160 °F	71 °C
Inlet Ports (2)	1/2" NPT(F)	1/2" NPT(F)
Discharge Ports (2)	3/8" NPT(F)	3/8" NPT(F)
Weight	29.2 lbs	13.3 kg
Dimensions	13.94 x 8.19 x 6.42"	354 x 208 x 163 mm

*Pump minimum is 100 RPM.

Dimensions

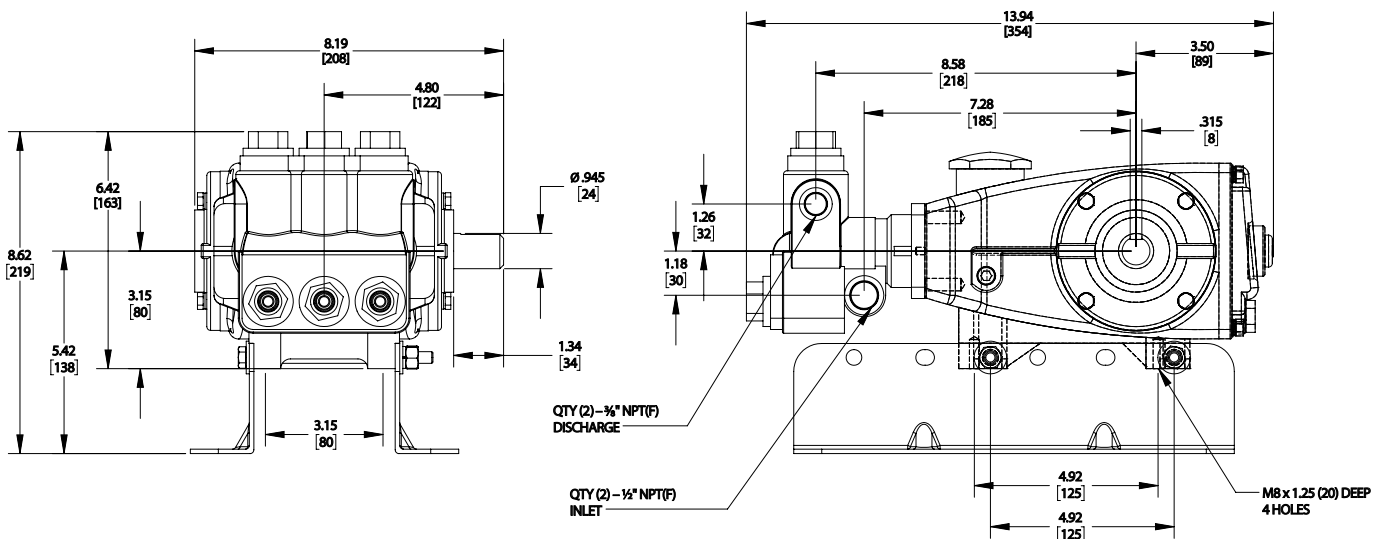

Contact Cat Pumps for more information at info@catpumps.com or 763-780-5440



CAT PUMPS
1681 - 94TH LANE N.E. MINNEAPOLIS, MN 55449-4324
PHONE (763) 780-5440 — FAX (763) 780-2958
e-mail: info@catpumps.com
www.catpumps.com