



Pumps & Accessories Catalog



Product Quality, Reliability and Support You Expect

www.catpumps.com

When It Needs to Run, Choose Cat Pumps



Cat Pumps designs and builds products to the highest quality level for one major reason: our customers depend on our products to keep their equipment running. Every design detail is optimized for long product life and reliable performance.

Cat Pumps embraces a zero defect manufacturing philosophy. Stringent process controls result in highly repeatable processes, yielding the highest level of product reliability. The Cat Pumps commitment to quality is legendary within the industry, earning the trust from customers worldwide.

Table of Contents

PRODUCT ORDERING	3	SPECIALTY ACCESSORIES	33
PUMP SELECTION	4	Easy Start Valve	33
PUMP FEATURES	4	Throttle Control	33
PLUNGER PUMPS	6	Mag-Jet and Pulsator Assemblies	33
Direct Drive, Hollow Shaft, Brass Manifold	6	Auto Shut-Off Assemblies	34
Direct Drive, Hollow Shaft, 316 Stainless Steel Manifold	7	LPS Monitors	34
Direct Drive, Hollow Shaft Gearbox, Brass Manifold	7	Float Valves	34
Direct Drive, Hollow Shaft Gearbox, 316 Stainless Steel Manifold	7	Pressure Switches	35
Direct Drive, Solid Shaft, Brass Manifold	8	Flow Switches	35
Direct Drive, Solid Shaft, 316 Stainless Steel Manifold	8	Thermostat	35
Direct Drive, Solid Shaft, Nickel Aluminum Bronze Manifold	8	OPERATOR CONTROLS	36
Solid Shaft, Brass Manifold	9	Guns, Gun & Lance Assemblies	36
Solid Shaft, 316 Stainless Steel Manifold	11	Lances	37
Solid Shaft, Duplex Stainless Steel Manifold	11	Nozzles	38
Solid Shaft, Nickel Aluminum Bronze Manifold	12	Vari-Nozzles	39
PISTON PUMPS	12	Foamers	39
Piston Pumps, Solid Shaft, Brass Manifold	12	Chemical Injectors	39
Piston Pumps, Solid Shaft, 316 Stainless Steel Manifold	12	Pulse Pumps	40
FLUSHED MANIFOLD PUMPS	13	LUBRICATION ACCESSORIES	41
Flushed Manifold Pumps, Solid Shaft	13	Crankcase Oil	41
Flushed Manifold Pumps, Solid Shaft, 316 Stainless Steel Manifold	13	Gear Lube	41
Flushed Manifold Pumps, Solid Shaft, Duplex Stainless Steel Manifold	13	Anti-Seize and Sealants	42
HIGH-TEMPERATURE PUMPS	14	Pump Protector	42
TRIETHYLENE GLYCOL (TEG) PUMPS, 240° F	14	PUMP ACCESSORIES	43
WASHOUT RESISTANT PUMPS	15	Oil Drain/Level Gauge Kits	43
B Series, Solid Shaft, Special Brass Manifold, Vehicle Wash	15	Protectors – Shaft and Oil Cap	43
LIQUID CO. PUMPS	15	Keys – Direct Drive	44
ATEX PUMPS	16	Keys – Belt Drive	44
1CX SERIES COMPACT MISTING PUMPS	16	Rail, Direct Mount and Complete Mounting Assemblies	45
1XP SERIES PORTABLE EXTRACTOR PUMPS	17	NEMA MOUNTING COMPONENTS	46
CENTRIFUGAL PUMPS	18	NEMA Bell Housing Assemblies	46
CUSTOM PUMPING SYSTEMS	20	NEMA Flexible Coupler Assemblies	46
ACCESSORIES	22	MOTOR OPTIONS	47
Typical Installation	23	SAE MOUNTING COMPONENTS	48
DISCHARGE ACCESSORIES	24	SAE Bell Housing Assemblies	48
CPC Pressure Regulators	24	SAE Flexible Coupler Assemblies	48
Unloaders, Trapped Pressure	25	DRIVE ACCESSORIES	49
Pressure Relief Valves	26	Hubs and Hub/Key Assemblies	49
Pop-Off Valves	27	Clutches	49
Pressure Gauges	28	Pulleys and Pulley/Hub w/Key	50
Valve Plug Adapters	28	SERVICE TOOLS	50
Quick Disconnect Assemblies	28	Pliers	50
Pulsation Dampeners	29	Oil Gauge Removal Tool	50
INLET ACCESSORIES	30	Seal Case Removal Tools	51
Filters	30	Piston Pump Tools	51
Inlet Pressure Gauges	30	Crankcase Oil Seal Kits for 35 Frame and 60 Frame	51
Inlet Pressure Regulators	31	NEW PRODUCTS AND UPDATES	52
Inlet Pressure Relief Valves	31	NEW INFORMATIONAL VIDEOS	53
Inlet Pressure Stabilizers	31	CAT PUMPS RESOURCES ON-DEMAND	54
Thermal Valves	32	CAT PUMPS LOCATIONS	56
Garden Hose Assemblies	32		

Product Ordering

Using This Catalog

The pump sections of this catalog are organized by drive type/flow rate/manifold materials (brass, 316 stainless steel, duplex stainless steel and nickel aluminum bronze). The model numbers listed represent standard pumps equipped with Buna-N seals and O-rings, except for specialty pumps, such as CO₂, TEG and portable extractors, which are fitted with unique seals for the application.

Standard Buna-N pump seals and/or O-rings can be changed by adding a suffix to the standard model number that represents the desired new seal material.

Optional Seal and O-Ring Configurations

MATERIAL CODE	DESCRIPTION	MAX. TEMPERATURE *	PUMP MODEL SUFFIX
NBR	Medium Nitrile (Buna-N) Seals and O-Rings	160° F (71° C)	—
FPM	Fluorocarbon (Viton®) Seals and O-Rings, Chemical Resistance	180° F (82° C)	.0110
EPDM	Ethylene Propylene Diene Monomer Seals and O-Rings	160° F (71° C)	.0220
HT	High-Temperature High-Pressure Seals	180° F (82° C)	.3000
STHT	High-Temperature High-Pressure Seals, Special Teflon® Low-Pressure Seals, NBR O-Rings	190° F (88° C)	.3400
	High-Temperature High-Pressure Seals, Special Teflon® Low-Pressure Seals, FPM O-Rings	190° F (88° C)	.3410
PTFE	Pure Polytetrafluoroethylene (Teflon®) Seals and Buna-N O-Rings	190° F (88° C)	.0700
	Pure Polytetrafluoroethylene (Teflon®) Seals and FPM O-Rings	200° F (93° C)	.0710
FFKM	Pure Polytetrafluoroethylene (Teflon®) Seals and Perfluoroelastomer O-Rings	200° F (93° C)	.0770
ST	Special Blend PTFE High and Low-Pressure Seals, Buna-N O-Rings	190° F (88° C)	.4400
	Special Blend PTFE High and Low-Pressure Seals, FPM O-Rings	200° F (93° C)	.4410
NBRS	Buna-N Silicone-Free Seals and O-Rings	160° F (71° C)	.6000

FPM = Fluorocarbon, EPDM = Ethylene Propylene Diene Monomer, HT = High-Temperature (EPDM Alternative), STHT = Special PTFE High-Temperature

PTFE = Pure Polytetrafluoroethylene, FFKM = Perfluoroelastomer, ST = Special PTFE, NBR = Medium Nitrile (Buna-N), NBRS = Buna-N Silicon-Free Seals and O-Rings

* See individual data sheet for each pump to verify actual maximum temperature allowed.

Viton® and Teflon® are registered trademarks of DuPont Dow Elastomers.

Example

Pump model 3535 can be changed from Buna-N to FPM. To convert pump model 3535 from Buna-N seals and O-rings to FPM (Viton®), add the suffix (.0110) to the standard pump model number (3535.0110). Use this new number when ordering the pump.

Cat Pumps configures a number of pumps for special applications and certifications such as ATEX, CO₂, TEG, Flushed, High-Temp and others. Please contact Cat Pumps directly at (763) 780-5440 for more information.

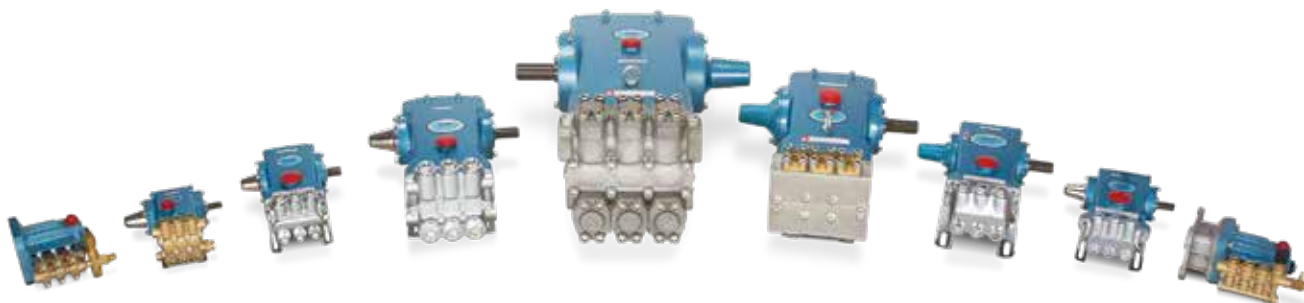

Pump Selection

Cat Pumps offers a complete line of positive displacement high-pressure pumps and systems that exceed industry expectations for reliability, availability and support. When high-pressure liquid is required, Cat Pumps is the supplier of choice for pumps, pumping systems and control accessories. Applications include CO₂ extraction, washdown, mist cooling, humidification, odor control and numerous other industry uses.

Product Performance Range

A wide range of pump options are available, including a variety of products that meet various industry certifications and directives.

- Flow: 0.13 to 240 gpm (0.49 to 908 lpm)
- Pressure: 100 to 10,000 psi (6.9 to 689 bar)
- RPM: 100 to 3,450
- Liquid Temperature: -10° to 200° F (-23° to 93° C)
- Manifold Materials: Brass, Nickel Aluminum Bronze, 304 and 316 Stainless Steel, Duplex Stainless Steel*
- Sealing Material: NBR, FPM, EPDM, FFKM, PTFE, Silicone-free*
- Drives: Electric, Engine, Hydraulic, Pneumatic

* Other materials available upon request.

Pump Features

- 1 Specially formulated, Cat Pumps exclusive high-pressure and low-pressure seals offer unmatched performance and seal life.
- 2 100% wet cup/seal design adds to service life by allowing pumped fluids to cool and lubricate the elastomers on both sides.
- 3 Stainless steel valves, seats and springs provide corrosion resistance, positive seating and long life.
- 4 Chromemoly crankshaft provides unmatched strength and surface hardness for long life.
- 5 The patented stepped piston rod with hard chrome-plated sleeve provides a durable wear surface and easy wet end servicing.
- 6 Precision-polished, solid ceramic plungers provide maximum resistance to corrosion and abrasion, extending seal life.
- 7 The high strength stainless steel plunger rods have a 360° supported crosshead providing uncompromising plunger rod alignment.
- 8 Matched oversized connecting rods are made of high-strength material with exceptional bearing quality.
- 9 Oversized ball bearings or tapered roller bearings provide extended bearing life.
- 10 High-strength, lightweight die cast aluminum crankcase with splash oil design allows operation at speeds as low as 100 RPM.

Pump Features

Plunger Pumps

(0.13–240 gpm, 100–10,000 psi)

Plunger pumps utilize spring-loaded closed and hydraulically opened inlet and discharge valves to direct flow through the pump manifold. At the beginning of the stroke, the plunger displaces the liquid in the manifold chamber, forcing the discharge valve open. When the plunger reaches the end of the stroke, the discharge valve closes. As the plunger rod begins its backward stroke, the inlet valve opens to allow more liquid into the manifold chamber, thereby keeping a smooth forward flow of liquid.

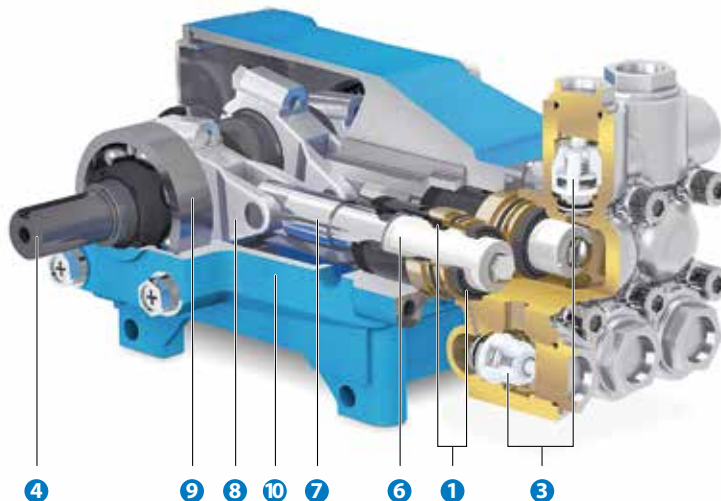

Piston Pumps

(3.0–60 gpm, 100–1,500 psi)

The design of the piston pump allows the fluid to move continually in one, smooth forward direction. This design allows greater suction capabilities and reduces the risk of cavitation provided the pump is properly primed. At the beginning of the stroke, the mechanically actuated inlet valve (and piston) will close. As the piston rod moves forward, the liquid is forced out through the discharge valves. Simultaneously, the liquid enters the pump inlet and flows in behind the inlet valve. As the piston rod begins the backward stroke, the inlet valve mechanically opens, permitting the liquid to continue its flow forward through the piston into the pumping chamber.

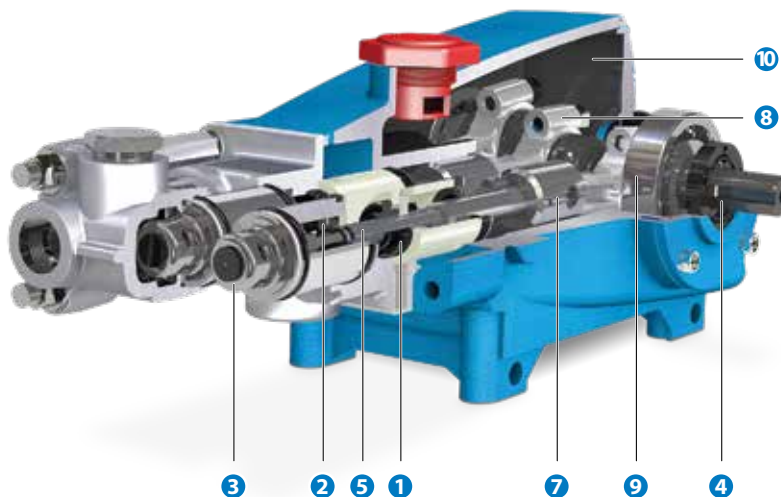

SF Series Pumps

(0.5–5.0 gpm, 100–2,500 psi)

In SF series pumps, both the inlet and discharge valves are spring-loaded closed and hydraulically opened, similar to plunger pumps, however, they have a flow-through ceramic plunger design. The continuous forward flow characteristic of piston pumps is utilized in conjunction with the packing design of the plunger pumps. These features give SF pumps both strong suction capabilities and higher pressure performances.

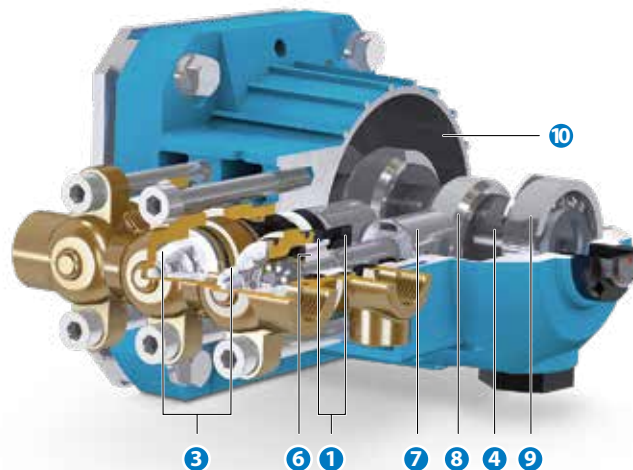

Plunger Pumps



Model 4DX10ER

DIRECT DRIVE, HOLLOW SHAFT, BRASS MANIFOLD

Electric Motor, 5/8" and 3/4", 56C Face

PUMP MODEL	MAXIMUM FLOW		MAXIMUM PRESSURE		RPM	SHAFT
	GPM	LPM	PSI	BAR		
4DX03ELR	0.3	1.1	2000	138	1750	5/8"
4DX10ER*	1.0	3.8	2000	138	3450	5/8"
4DX15ER*	1.5	5.7	2000	138	3450	5/8"
4DX20ER*	2.0	7.6	2000	138	3450	5/8"
4SP21ELR*	2.1	7.9	2000	138	1750	5/8"
4DX27ER*	2.7	10.3	2000	138	3450	5/8"
4SP29ELR*	2.85	10.8	1200	83	1750	5/8"
4DX30ER*	3.0	11.4	2000	138	3450	5/8"
2SF35ES	3.5	13.3	1500	103	3450	5/8"
2SF35GES	3.5	13.3	2000	138	3450	3/4"
2SFP500EL	5.0	19.0	500	34.5	1750	5/8"

Note: Pumps rated at 3450 rpm can operate at 1725 rpm, reducing flow by 50%.

*"R" models are built with an integral pressure regulator valve. "U" models are available with an integral unloader valve.



Model 2SF35ES

DIRECT DRIVE, HOLLOW SHAFT, BRASS MANIFOLD

Electric Motor, 1 1/8", 184TC Face

PUMP MODEL	MAXIMUM FLOW		MAXIMUM PRESSURE		RPM	SHAFT
	GPM	LPM	PSI	BAR		
5SP30ELU	3.0	11.4	3000	207	1750	1 1/8"
5SP35ELU	3.5	13.3	2500	172	1750	1 1/8"
5SP40ELU	4.0	15.2	2000	138	1750	1 1/8"
5SP30ELR*	3.0	11.4	3000	207	1750	1 1/8"
5SP35ELR*	3.5	13.3	2500	172	1750	1 1/8"
5SP40ELR*	4.0	15.2	2000	138	1750	1 1/8"

*"R" models are built with an integral pressure regulator valve.



Model 5SP35ELU

DIRECT DRIVE, HOLLOW SHAFT, BRASS MANIFOLD

Engine, 3/4"

PUMP MODEL	MAXIMUM FLOW		MAXIMUM PRESSURE		RPM	SHAFT	HP Typical Gas Engine*
	GPM	LPM	PSI	BAR			
4DNX25GSI	2.5	9.5	3000	207	3450	3/4"	6.5
4DNX27GSI	2.7	10.3	3000	207	3450	3/4"	8
4DX29GUIF	2.9	11.0	2600	179	3450	3/4"	6.5
2SF30GS	3.0	11.4	2000	138	3450	3/4"	6.5
2SF35GS	3.5	13.3	2000	138	3450	3/4"	8

*Consult engine manufacturer for actual torque available at required speed.



Model 66DX40G1I

DIRECT DRIVE, HOLLOW SHAFT, BRASS MANIFOLD

Engine, 1"

PUMP MODEL	MAXIMUM FLOW		MAXIMUM PRESSURE		RPM	SHAFT	HP Typical Gas Engine*
	GPM	LPM	PSI	BAR			
66DX30G1I	3.0	11.4	4000	276	3400	1"	13
4SPX32G1I	3.2	12.2	3000	207	3450	1"	9
66DX35G1I	3.5	13.3	4000	276	3400	1"	13
66DX40G1I	4.0	15.2	4000	276	3400	1"	16
66DX50G1I	5.0	19.0	3500	241	3250	1"	13

*Consult engine manufacturer for actual torque available at required speed.

Plunger Pumps

DIRECT DRIVE, HOLLOW SHAFT, 316 STAINLESS STEEL MANIFOLD

Electric Motor, 5/8", 56C Face

PUMP MODEL	MAXIMUM FLOW		MAXIMUM PRESSURE		RPM	SHAFT
	GPM	LPM	PSI	BAR		
2SF05SEEL	0.5	1.9	1200	83	1725	5/8"
2SF10SEEL	1.0	3.8	1200	83	1725	5/8"
2SF15SEEL	1.5	5.7	1200	83	1725	5/8"
2SF22SEEL	2.2	8.4	1200	83	1725	5/8"
2SFQ25SEEL	2.5	9.5	1200	83	1725	5/8"
2SFQ29SEEL	2.85	10.8	1200	83	1725	5/8"
2SFQ35SEEL	3.5	13.3	1200	83	1725	5/8"
2SFQ42SEEL	4.2	15.9	1200	83	1725	5/8"



Model 2SF22SEEL

DIRECT DRIVE, HOLLOW SHAFT GEARBOX, BRASS MANIFOLD

Engine, 3/4" and 1"

PUMP MODEL	MAXIMUM FLOW		MAXIMUM PRESSURE		RPM	SHAFT	HP Typical Gas Engine*
	GPM	LPM	PSI	BAR			
740G1	2.8	10.6	5000	345	3465	1"	13
3CP1120G	3.5	13.3	2200	152	3600	3/4"	8
760G1	3.5	13.3	5000	345	3465	1"	16
5CP3160CSSG1	4.0	15.2	3500	241	3320	1"	13
5CP3120CSSG1	4.5	17.0	3500	241	3353	1"	16
60G1	4.5	17.0	4000	276	3450	1"	18
700G1	4.5	17.0	5000	345	3465	1"	20
5CP3150CSSG1	5.0	19.0	3000	207	3450	1"	13
5CP5135CSSG1	5.8	21.9	3500	241	3450	1"	13
5CP5140CSSG1	6.2	23.4	3000	207	3450	1"	18
5CP6120CSSG1	7.2	27.2	1500	103	3450	1"	8
5CP6180CSSG1	8.0	30.3	1500	103	3450	1"	11
56G1	8.0	30.3	2500	172	3600	1"	16
7CP6165CSG1	8.0	30.3	3500	241	3265	1"	25
56HSG1	8.0	30.3	3000	207	3600	1"	22
5CP6190G1	9.7	36.7	1200	83	3450	1"	11
7CP6110CSG1	10.0	38.0	2000	138	3400	1"	18
7CP6160CSG1	10.0	38.0	2500	172	3400	1"	22
7CP6170G1	12.0	45.4	1800	124	3264	1"	16

Note: All 1" Gearboxes are also available in 1 1/8" size. (G118)

*Consult engine manufacturer for actual torque available at required speed.



Model 5CP3120CSSG1



Model 7CP6165CSG1

DIRECT DRIVE, HOLLOW SHAFT GEARBOX, 316 STAINLESS STEEL MANIFOLD

Engine, 3/4" and 1"

PUMP MODEL	MAXIMUM FLOW		MAXIMUM PRESSURE		RPM	SHAFT	HP Typical Gas Engine*
	GPM	LPM	PSI	BAR			
3CP1241G	3.0	11.4	2000	138	3600	3/4"	5
3CP1221G	3.5	13.3	1500	103	3600	3/4"	5
3CP1211G	3.8	14.4	1500	103	3400	3/4"	5
5CPQ6241CSG1	4.0	15.2	2000	138	3600	1"	8
781G1	4.5	17.0	5000	345	3465	1"	20
5CPQ6251G1	5.0	19.0	2000	138	3600	1"	9
5CPQ6221G1	7.4	28.0	1500	103	3600	1"	9
7CP6111CSG1	10.0	38.0	2000	138	3400	1"	18

Note: All 1" Gearboxes are also available in 1 1/8" size. (G118).

*Consult engine manufacturer for actual torque available at required speed.



Model 7CP6111CSG1

Plunger Pumps

DIRECT DRIVE, SOLID SHAFT, BRASS MANIFOLD

Electric Motor–Bell Housing



Model 3CP1120



Model 7CP6185CS

PUMP MODEL	MAXIMUM FLOW		MAXIMUM PRESSURE		RPM	SHAFT
	GPM	LPM	PSI	BAR		
5CP4110CSS	2.2	8.4	4000	276	1750	20 mm
3CP1130	2.4	9.1	2200	138	1725	16.5 mm
5CP3105CSS	2.5	9.5	3500	241	1750	20 mm
5CP4112CSS	2.7	10.3	4000	276	1750	20 mm
740	2.9	11.0	5000	345	1750	24 mm
5CP4114CSS	3.2	12.1	4000	276	1750	20 mm
3CP1140	3.6	13.7	2200	152	1725	16.5 mm
5CP3110CSS	3.6	13.7	3500	241	1750	20 mm
760	3.6	13.6	5000	345	1750	24 mm
5CP4116CSS	3.8	14.4	4000	276	1750	20 mm
340	4.0	15.2	1800	124	1725	20mm
5CP2140WCS	4.0	15.2	2500	172	1725	20 mm
3CP1120	4.2	16.0	2200	152	1725	16.5 mm
5CP4118CSS	4.2	16.0	4000	276	1750	20 mm
5CP3160CSS	4.3	16.3	3500	241	1750	20 mm
5CP4120CSS	4.5	17.0	4000	276	1750	20 mm
60	4.7	17.9	4000	276	1750	24 mm
700	4.7	17.9	5000	345	1750	24 mm
5CP3120CSS	4.8	18.2	3000	207	1750	20 mm
350	5.0	19.0	1500	103	1725	20mm
5CP2150W	5.0	19.0	2000	138	1725	20 mm
5CP3150CSS	5.2	19.8	3000	207	1750	20 mm
5CP5120	6.0	22.8	2500	172	1750	20 mm
5CP5135CSS	6.0	22.8	3500	241	1750	20 mm
5CP5140CSS	6.4	24.3	3000	207	1750	20 mm
5CP6120	7.4	28.1	1500	103	1725	20 mm
56	8.0	30.3	2500	172	1760	24 mm
56HS	8.0	30.3	3000	207	1760	24 mm
5CP6180CSS	8.2	31.0	1500	103	1750	20 mm
5CP6190	10.0	38.0	1200	83	1750	20 mm
7CP6110CS	10.5	39.9	2000	138	1750	24 mm
7CP6160CS	10.6	40.1	2500	172	1750	24 mm
1730	15.8	59.8	1500	103	1750	30 mm

DIRECT DRIVE, SOLID SHAFT, 316 STAINLESS STEEL MANIFOLD

Electric Motor–Bell Housing



Model 3CP1231

PUMP MODEL	MAXIMUM FLOW		MAXIMUM PRESSURE		RPM	SHAFT
	GPM	LPM	PSI	BAR		
3CP1231	2.3	8.7	2000	138	1725	16.5 mm
784	2.9	11.0	5000	345	1750	24 mm
3CP1241	3.6	13.7	2000	138	1725	16.5 mm
786	3.6	13.7	5000	345	1750	24 mm
5CPQ6241CS	4.0	15.2	2000	138	1725	20 mm
3CP1221	4.2	16.0	2000	138	1725	16.5 mm
781	4.7	17.8	5000	345	1750	24 mm
3CP1211CS	5.0	19.0	1700	117	1750	16.5 mm
5CPQ6251	5.0	19.0	2000	138	1725	20 mm
5CPQ6281CSS	5.5	20.9	2000	138	1725	20 mm
5CPQ6271CSS	6.6	25.1	1800	124	1725	20 mm
5CPQ6221	7.4	28.0	1500	103	1725	20 mm
7CP6111CS	10.5	39.9	2000	138	1750	24 mm
1731	15.8	59.8	1500	103	1750	30 mm

DIRECT DRIVE, SOLID SHAFT, NICKEL ALUMINUM BRONZE MANIFOLD

Electric Motor–Bell Housing



Model 277

PUMP MODEL	MAXIMUM FLOW		MAXIMUM PRESSURE		RPM	SHAFT
	GPM	LPM	PSI	BAR		
237	2.3	8.7	1500	103	1725	16.5 mm
247	3.6	13.7	1200	83	1725	16.5 mm
277	4.2	16.0	1000	69	1725	16.5 mm
347	4.0	15.2	1800	124	1725	20 mm
357	5.0	19.0	1500	103	1725	20 mm

Plunger Pumps

SOLID SHAFT, BRASS MANIFOLD

PUMP MODEL	MAXIMUM FLOW		MAXIMUM PRESSURE		RPM	SHAFT
	GPM	LPM	PSI	BAR		
5CP4110CSS	2.2	8.4	4000	276	1750	20 mm
3CP1130	2.4	9.1	2200	138	1725	16.5 mm
5CP3105CSS	2.5	9.5	3500	241	1750	20 mm
5CP4112CSS	2.7	10.3	4000	276	1750	20 mm
740	2.9	11.0	5000	345	1750	24 mm
1810*	3.0	11.4	10000	689	1500	30 mm
5CP4114CSS	3.2	12.1	4000	276	1750	20 mm
3CP1140	3.6	13.7	2200	152	1725	16.5 mm
5CP3110CSS	3.6	13.7	3500	241	1750	20 mm
760	3.6	13.7	5000	345	1750	24 mm
5CP4116CSS	3.8	14.4	4000	276	1750	20 mm
310	4.0	15.2	2200	152	950	20 mm
5CP2120W	4.0	15.2	2500	172	950	20 mm
5CP2140WCS	4.0	15.2	2500	172	1725	20 mm
3CP1120	4.2	16.0	2200	152	1725	16.5 mm
5CP4118CSS	4.2	16.0	4000	276	1750	20 mm
5CP3160CSS	4.3	16.3	3500	241	1750	20 mm
45	4.5	17.0	3500	241	1645	20mm
5CP3120CSS	4.5	17.0	3500	241	1645	20 mm
57	4.5	17.0	4000	276	1285	24 mm
5CP4120CSS	4.5	17.0	4000	276	1750	20 mm
60	4.7	17.9	4000	276	1750	24 mm
700	4.7	17.9	5000	345	1750	24 mm
5CP3120CSS	4.8	18.2	3000	207	1750	20 mm
310	5.0	19.0	1500	103	1190	20 mm
5CP2150W	5.0	19.0	2000	138	1725	20 mm
530	5.0	19.0	2500	172	1100	24 mm
5CP5120	5.0	19.0	3000	207	1415	20 mm
550	5.0	19.0	3000	207	1415	24mm
5CP3150CSS	5.2	19.7	3000	207	1750	20 mm
56	5.5	20.9	3500	241	1210	24 mm
5CP5140CSS	5.5	20.9	3500	241	1500	20 mm
5CP5120	6.0	22.8	2500	172	1750	20 mm
5CP5135CSS	6.0	22.8	3500	241	1750	20 mm
1570	6.0	22.8	6000	414	1350	30 mm
5CP5140CSS	6.4	24.3	3000	207	1750	20 mm
5CP6180CSS	6.9	26.1	1500	103	1450	20 mm
650	7.0	26.6	3000	207	1000	30 mm
5CP6120	7.4	28.1	1500	103	1725	20 mm
5CP6120CS	7.4	28.1	1500	103	1725	20 mm
5CP6190	8.0	30.3	1450	100	1450	20 mm
56	8.0	30.3	2500	172	1760	24 mm
56HS	8.0	30.3	3000	207	1760	24 mm
7CP6185CS	8.0	30.3	3500	241	1320	24mm
5CP6180CSS	8.2	31.0	1500	103	1750	20 mm
1560	9.0	34.0	4000	276	1280	30 mm
5CP6190	10.0	38.0	1200	83	1750	20 mm
1050	10.0	38.0	2200	152	958	30 mm
660	10.0	38.0	3000	207	1429	30 mm
3550	10.0	38.0	6000	414	880	35 mm
6810*	10.0	38.0	10000	689	600	45 mm
7CP6110CS	10.5	39.9	2000	138	1750	24 mm
7CP6160CS	10.6	40.1	2500	172	1750	24 mm
7CP6170	11.0	41.6	2000	138	1450	24 mm
7CP6170	12.0	45.4	1800	124	1600	24 mm
1580	12.0	45.4	3000	207	1180	30 mm
1050	12.3	46.5	1800	124	1180	30 mm
1530	15.6	59.3	1500	103	1450	30 mm
1730	15.8	59.8	1500	103	1750	30 mm

*17-4SS Stainless Manifolds



Model 1810



Model 310



Model 700



Model 5CP2120W

Plunger Pumps

SOLID SHAFT, BRASS MANIFOLD



Model 1570



Model 660



Model 1540E



Model 3535

PUMP MODEL	MAXIMUM FLOW		MAXIMUM PRESSURE		RPM	SHAFT
	GPM	LPM	PSI	BAR		
2560	16.0	60.5	3000	207	1510	30 mm
1540E	19.3	73.0	1200	83	1180	30 mm
2510	20.0	76.0	2000	138	1450	30 mm
2565	20.0	76.0	2500	172	1450	30 mm
3560	20.0	76.0	4000	276	1160	35 mm
2530	25.0	95.0	1200	83	1025	30 mm
3520	25.0	95.0	2000	138	870	35 mm
3570	30.0	113.6	2500	172	1080	35 mm
3570S*	30.0	113.6	3000	207	1080	35 mm
3560	25.0	95.0	3000	207	1450	35 mm
3535	36.0	136.2	1200	83	800	35 mm
3535HS*	40.0	152.0	2000	138	888	35 mm
6835	40.0	152.0	3000	207	625	45 mm
3545	45.0	171.0	1000	69	765	35 mm
3545HS*	50.0	189.3	1500	103	850	35 mm
67070	50.0	189.3	2000	138	653	45 mm
67070*	50.0	189.3	3000	207	653	45 mm
6760	60.0	228.0	1200	83	520	45 mm
67070*	65.0	246.0	2000	138	850	45 mm
6775	75.0	285.0	1200	83	650	45 mm

*Intermittent duty cycle is defined as operating pump at maximum rated flow and pressure for no more than 50% of time in any given hour.

Selecting a Drive

A variety of different drive options are offered by Cat Pumps. Most systems are belt-driven by a pulley or clutch, but there are also direct-drive options such as direct coupled, gearbox or hollow shaft direct drive.

Commonly Used Formulas

$$\text{Desired rpm} = \text{Desired gpm} \times \frac{\text{Rated rpm}}{\text{Rated gpm}} \quad \text{Pump Pulley}^* \times \frac{\text{Pump rpm}}{\text{Motor/Engine rpm}} = \text{Motor Pulley}^*$$

*Pitch Diameter

Selecting a Power Source

Positive displacement pumps can use a variety of different power sources, including electric motors, gas or diesel engines, hydraulic and pneumatic motors. Note: system power sources must be sized with adequate horsepower to handle the maximum system flow and pressure required.

Commonly Used Formulas

$$\text{Electric Motor Horsepower (HP)}^* = \frac{\text{gpm} \times \text{psi}}{1460} \quad \text{Hydraulic Torque (ft. lbs.) Required} = 3.6 \times \frac{\text{gpm} \times \text{psi}}{\text{rpm}}$$

*Standard 85% Overall Efficiency

Plunger Pumps

SOLID SHAFT, 316 STAINLESS STEEL MANIFOLD

PUMP MODEL	MAXIMUM FLOW		MAXIMUM PRESSURE		RPM	SHAFT
	GPM	LPM	PSI	BAR		
3CP1231	2.3	8.7	2000	138	1725	16.5 mm
784	2.9	11.0	5000	345	1750	24 mm
3CP1241	3.6	13.7	2000	138	1725	16.5 mm
786	3.6	13.7	5000	345	1750	24 mm
341	4.0	15.2	1800	124	1725	20 mm
5CPQ6241CS	4.0	15.2	2000	138	1725	20 mm
311	4.0	15.2	2200	152	950	20 mm
3CP1221	4.2	16.0	2000	138	1725	16.5 mm
781	4.7	17.9	5000	345	1750	24 mm
351	5.0	19.0	1500	103	1725	20 mm
3CP1211CS	5.0	19.0	1700	117	1750	16.5 mm
5CPQ6251	5.0	19.0	2000	138	1725	20 mm
5CPQ6221	6.0	22.8	2000	138	1400	20 mm
5CPQ6221	7.4	28.0	1500	103	1725	20 mm
1051	10.0	38.0	2200	152	958	30 mm
3501	10.0	38.0	5000	345	915	35 mm
7CP6111CS	10.5	39.9	2000	138	1750	24 mm
7CP6171CS	11.0	41.6	2000	138	1450	24 mm
7CP6171CS	12.0	45.0	1800	124	1600	24 mm
1051	12.3	46.5	1800	124	1180	30 mm
3511	14.0	53.2	3000	207	800	35 mm
6811	15.0	57.0	5000	345	630	45 mm
6801	15.0	57.0	7000	483	630	45 mm
1531	15.6	59.0	1500	103	1450	30 mm
1731	15.8	59.8	1500	103	1750	30 mm
1541	19.3	73.0	1200	83	1180	30 mm
2511	20.0	76.0	1500	103	1450	30 mm
2531	25.0	95.0	1200	83	1025	30 mm
3521DHS	25.0	95.0	2000	138	870	35 mm
6821	25.0	95.0	3000	207	615	45 mm
3531DHS	36.0	136.2	1200	83	800	35 mm
3531DHS*	40.0	152.0	2000	138	888	35 mm
6831	40.0	152.0	2300	159	625	45 mm
3541DHS	45.0	171.0	1000	69	765	35 mm
6841	48.0	182.4	2000	138	615	45 mm
3541DHS*	50.0	189.3	1500	103	850	35 mm
6761	60.0	228.0	1200	83	520	45 mm

*Intermittent duty cycle is defined as operating pump at maximum rated flow and pressure for no more than 50% of time in any given hour.



Model 311



Model 1051



Model 2531

SOLID SHAFT, DUPLEX STAINLESS STEEL MANIFOLD

PUMP MODEL	MAXIMUM FLOW		MAXIMUM PRESSURE		RPM	SHAFT
	GPM	LPM	PSI	BAR		
1051D	10.0	38.0	2200	152	958	30 mm
661D	10.0	38.0	3000	207	1429	30 mm
1051D	12.3	46.5	1800	124	1180	30 mm
6762	60.0	228.0	1200	83	520	45 mm
67102	80.0	302.8	1200	83	540	45 mm
67102	100.0	378.5	1000	69	680	45 mm
157R060	100.0	380.0	2700	186	310	100 mm
152R060	115.0	437.0	1200	83	360	100 mm
152R061	115.0	437.0	2000	138	360	100 mm
152R080	200.0	760.0	1200	83	355	100 mm
152R081	200.0	760.0	1560	108	355	100 mm
152R100	240.0	912.0	1000	69	270	100 mm



Model 6762

Plunger Pumps



Model 277



Model 6767

SOLID SHAFT, NICKEL ALUMINUM BRONZE MANIFOLD

PUMP MODEL	MAXIMUM FLOW		MAXIMUM PRESSURE		RPM	SHAFT
	GPM	LPM	PSI	BAR		
237	2.3	8.7	1500	103	1725	16.5 mm
277	3.5	13.3	1500	103	1420	16.5 mm
247	3.6	13.7	1200	83	1725	16.5 mm
347	4.0	15.2	1800	124	1725	20 mm
317	4.0	15.2	2200	152	950	20 mm
277	4.2	16.0	1000	69	1725	16.5 mm
357	5.0	19.0	1500	103	1725	20 mm
1057	10.0	38.0	2200	152	958	30 mm
3507HS	10.0	38.0	5000	345	915	35 mm
1057	12.3	46.5	1800	124	1180	30 mm
3517HS	14.0	53.2	3000	207	800	35 mm
2537	25.0	95.0	1200	83	1025	30 mm
3527HS	25.0	95.0	2000	138	870	35 mm
3537	36.0	136.2	1200	83	800	35 mm
3537HS*	40.0	152.0	2000	138	888	35 mm
3547HS	45.0	171.0	1000	69	765	35 mm
6747	48.0	182.4	2000	138	615	45 mm
3547HS*	50.0	189.3	1500	103	850	35 mm
6767	60.0	228.0	1200	83	520	45 mm

*Intermittent duty cycle is defined as operating pump at maximum rated flow and pressure for no more than 50% of time in any given hour.

Piston Pumps



Model 280

PISTON PUMPS, SOLID SHAFT, BRASS MANIFOLD

PUMP MODEL	MAXIMUM FLOW		MAXIMUM PRESSURE		RPM	SHAFT
	GPM	LPM	PSI	BAR		
280	3.0	11.4	1000	69	1330	16.5 mm
290	3.5	13.3	1200	83	1200	16.5 mm
333	4.0	15.2	1200	83	1070	16.5 mm
430	5.0	19.0	1000	69	1040	16.5 mm
323	5.0	19.0	1500	103	1000	20 mm
623	6.0	22.8	1200	83	850	25 mm
820	10.0	38.0	1000	69	940	25 mm
390	12.0	45.4	600	41	1200	20 mm
1010	13.0	49.4	700	48	900	25 mm
2520*	25.0	95.0	800	55	772	30 mm
6040	40.0	152.0	1500	103	500	45 mm
6020	60.0	228.0	1000	69	500	45 mm

*Available as a model 2520C with flushed inlet manifold.



Model 6020

PISTON PUMPS, SOLID SHAFT, 316 STAINLESS STEEL MANIFOLD

PUMP MODEL	MAXIMUM FLOW		MAXIMUM PRESSURE		RPM	SHAFT
	GPM	LPM	PSI	BAR		
281	3.0	11.4	1000	69	1330	16.5 mm
291	3.5	13.3	1200	83	1200	16.5 mm
331	4.0	15.2	1200	83	1070	16.5 mm
431	5.0	19.0	1000	69	1040	16.5 mm
621	6.0	22.8	1200	83	850	25 mm
821	10.0	38.0	1000	69	940	25 mm
1011	13.0	49.4	700	48	900	25 mm
6041	40.0	152.0	1500	103	500	45 mm
6021	60.0	228.0	1000	69	500	45 mm

Flushed Manifold Pumps

FLUSHED MANIFOLD PUMPS, SOLID SHAFT

PUMP MODEL	MAXIMUM FLOW		MAXIMUM PRESSURE		RPM	SHAFT
	GPM	LPM	PSI	BAR		
1810K*	3.0	11.4	10000	689	1500	30 mm
1530C	15.6	59.0	1500	103	1450	30 mm
1540EC	19.3	73.0	1200	83	1180	30 mm
2520C	25.0	95.0	800	55	772	30 mm
3520C	25.0	95.0	2000	138	870	35 mm
3570C	30.0	114.0	2500	172	1080	30 mm
3535C	36.0	136.2	1200	83	800	35 mm

Model numbers ending in "C" indicate flushed cast manifold and "K" indicate flushed block manifold.

*17 - 4SS Stainless Steel Manifolds



Model 3520C

FLUSHED MANIFOLD PUMPS, SOLID SHAFT, 316 STAINLESS STEEL MANIFOLD

PUMP MODEL	MAXIMUM FLOW		MAXIMUM PRESSURE		RPM	SHAFT
	GPM	LPM	PSI	BAR		
341C	4.0	15.2	1800	124	1725	20 mm
311C	4.0	15.2	2200	152	950	20 mm
781K	4.7	17.9	5000	345	1750	24 mm
351C	5.0	19.0	1500	103	1725	20 mm
1051C	10.0	38.0	2200	152	958	30 mm
661C	10.0	38.0	3000	207	1429	30 mm
3501C	10.0	38.0	5000	345	915	35 mm
7CP6171CCS	11.0	41.6	2000	138	1450	24 mm
7CP6171CCS	12.0	45.0	1800	124	1600	24 mm
7CP6111CCS	10.5	39.9	2000	138	1750	24 mm
1051C	12.3	46.5	1800	124	1180	30 mm
3511C	14.0	53.2	3000	207	800	35 mm
6811K	15.0	57.0	5000	345	630	45 mm
6801K	15.0	57.0	7000	483	630	45 mm
1541C	19.3	73.0	1200	83	1180	30 mm
2531C	25.0	95.0	1200	83	1025	30 mm
3521CHS	25.0	95.0	2000	138	870	35 mm
6821K	25.0	95.0	3000	207	615	45 mm
3531CHS	36.0	136.2	1200	83	800	35 mm
3531CHS*	40.0	152.0	2000	138	888	35 mm
6831K	40.0	152.0	2300	159	625	45 mm
3541CHS	45.0	171.0	1000	69	765	35 mm
3541CHS*	50.0	189.3	1500	103	850	35 mm
6841K	48.0	182.4	2000	138	615	45 mm
6861K	60.0	228.0	1200	83	520	45 mm

Model numbers ending in "C" indicate flushed cast manifold and "K" indicate flushed block manifold.

*Intermittent duty cycle is defined as operating pump at maximum rated flow and pressure for no more than 50% of time in any given hour.



Model 781K



Model 1051C

FLUSHED MANIFOLD PUMPS, SOLID SHAFT, DUPLEX STAINLESS STEEL MANIFOLD

PUMP MODEL	MAXIMUM FLOW		MAXIMUM PRESSURE		RPM	SHAFT
	GPM	LPM	PSI	BAR		
67102C	100.0	378.5	1000	69	680	45 mm
152R060C	115.0	437.0	1200	83	360	100 mm
152R080C	200.0	760.0	1200	83	355	100 mm
152R100C	240.0	912.0	1000	69	270	100 mm

Model numbers ending in "C" indicate flushed cast manifold and "K" indicate flushed block manifold.



Model 67102C

High-Temperature Pumps



Model 1051.3400

.3400 SERIES, HIGH-TEMPERATURE AND INTERMITTENT RUN DRY

The “.3400” Series pumps feature specially blended seals and V-packings, expanding pump operating performance to 190° F / 88° C. This modification also allows the pump to run intermittently dry without damaging the seals. Standard plunger pumps can be fitted with these specially blended seals. Ordering this configuration requires adding .3400 to pump base model. For example, a 310 pump fitted with high temperature seals will be 310.3400. Contact Cat Pumps for additional information.

Triethylene Glycol (TEG) Pumps, 240° F



Model 3CP1120.44101

HIGH-TEMPERATURE/TEG PUMPS, SOLID SHAFT, BRASS MANIFOLD

PUMP MODEL	MAXIMUM FLOW		MAXIMUM PRESSURE		RPM	SHAFT
	GPM	LPM	PSI	BAR		
3CP1130.44101	2.4	9.1	2200	152	1725	16.5 mm
5CP3105CS.44101	2.5	9.5	3500	241	1750	20 mm
3CP1140.44101	3.6	13.7	2200	152	1725	16.5 mm
5CP2120W.44101	4.0	15.2	2500	172	950	20 mm
5CP2140CS.44101	4.0	15.2	2500	172	1725	20 mm
3CP1120.44101	4.2	16.0	2200	152	1725	16.5 mm
5CP2150W.44101	5.0	19.0	2000	138	1725	20 mm
5CP5135CSS.44101	6.0	22.8	3500	241	1750	20 mm
5CP6120.44101	7.4	28.0	1500	103	1725	20 mm
1050.44101	10.0	38.0	2200	152	958	30 mm
1050.44101	12.3	46.5	1800	124	1180	30 mm
1530.44101	15.6	59.0	1500	103	1450	30 mm
1540E.44101	19.3	73.0	1200	83	1180	30 mm
2510.44101	20.0	76.0	2000	138	1450	30 mm
2530.44101	25.0	95.0	1200	83	1025	30 mm
3520.44101	25.0	136.0	2000	138	870	35 mm
3535.44101	36.0	136.0	1200	83	800	35 mm



Model 1050.44101

HIGH-TEMPERATURE/TEG PUMPS, SOLID SHAFT, 316 STAINLESS STEEL

PUMP MODEL	MAXIMUM FLOW		MAXIMUM PRESSURE		RPM	SHAFT
	GPM	LPM	PSI	BAR		
3CP1231.44101	2.3	8.7	2000	138	1725	16.5 mm
3CP1241.44101	3.6	13.7	2000	138	1725	16.5 mm
5CPQ6241.44101	4.0	15.2	2000	138	1725	20 mm
3CP1221.44101	4.2	16.0	2000	138	1725	16.5 mm
5CPQ6251.44101	5.0	19.0	2000	138	1725	20 mm
5CPQ6221.44101	6.0	22.8	2000	138	1400	20 mm
5CPQ6221.44101	7.4	28.0	1500	103	1725	20 mm
1051.44101	10.0	38.0	2200	152	958	30 mm
3501.44101	10.0	38.0	5000	345	915	35 mm
1051.44101	12.3	46.5	1800	124	1180	30 mm
1531.44101	15.6	59.0	1500	103	1450	30 mm
1541.44101	19.3	73.0	1200	83	1180	30 mm
3521DHS.44101	25.0	95.0	2000	138	870	35 mm
2531.44101	25.0	95.0	1200	83	1025	30 mm
3531DHS.44101	36.0	136.2	1200	83	800	35 mm
3531DHS.44101*	40.0	152.0	2000	138	888	35 mm

*Intermittent duty cycle is defined as operating pump at maximum rated flow and pressure for no more than 50% of time in any given hour.

Washout Resistant Pumps

B SERIES, SOLID SHAFT, SPECIAL BRASS MANIFOLD, VEHICLE WASH

PUMP MODEL	MAXIMUM FLOW		MAXIMUM PRESSURE		RPM	SHAFT
	GPM	LPM	PSI	BAR		
340B	4.0	15.2	1800	124	1725	20 mm
310B	4.0	15.2	2200	152	950	20 mm
5CP2120B	4.0	15.2	2500	172	950	20 mm
5CP2140BCS	4.0	15.2	2500	172	1725	20 mm
350B	5.0	19.0	1500	103	1725	20 mm
5CP2150B	5.0	19.0	2000	138	1725	20 mm



Model 310B

Liquid CO₂ Pumps

Cat Pumps liquid CO₂ series of pumps feature modifications to accommodate the unique properties of liquid CO₂. Specialty seals are used to handle low lubricity and low temperature that liquid CO₂ applications require. Pump manifolds are modified to allow higher inlet pressures and discharge pressures up to 7,000 psi (483 bar). Drive-end and manifold material combinations are available to cover a wide flow range of flow from 0.34 to 50 gpm (1.3 to 189.2 lpm).

Cat Pumps offers full technical and engineering support to properly select pumps for the specific application. Pumps are available in brass and 316 stainless steel. Cat Pumps has provided liquid CO₂ pumping solutions for over 25 years, working closely with research facilities, universities, equipment manufacturers and site locations to design and provide the best solutions. Please contact Cat Pumps for additional information.



Model 1530RSCM.CO2

CO₂ Pump Features:

- 1 Inverted manifolds provide improved passage for trapped vapor bubbles to escape through the inlet and return to the tank, avoiding potential issues caused by bubbles in the discharge line. Specially-formulated seals allow for improved operation with the low temperature and low lubricity properties of CO₂.
- 2 Drive-ends contain upgraded materials and component design to accommodate the high inlet pressures required to maintain CO₂ in a liquid state.
- 3 Ported inlet manifolds offer protection from damage caused by CO₂ leaking past the high-pressure seals. Included check valve prevents ambient air from entering the pump manifold.
- 4 Vented seal retainers offer protection against any CO₂ that escapes past the pressure seals, preventing damage to the drive-ends or pump manifolds.*
- 5 Check valves allow the escape of vapor while preventing air and humidity from entering.*

* Vented seal retainers only required on 8 frame and larger pumps.

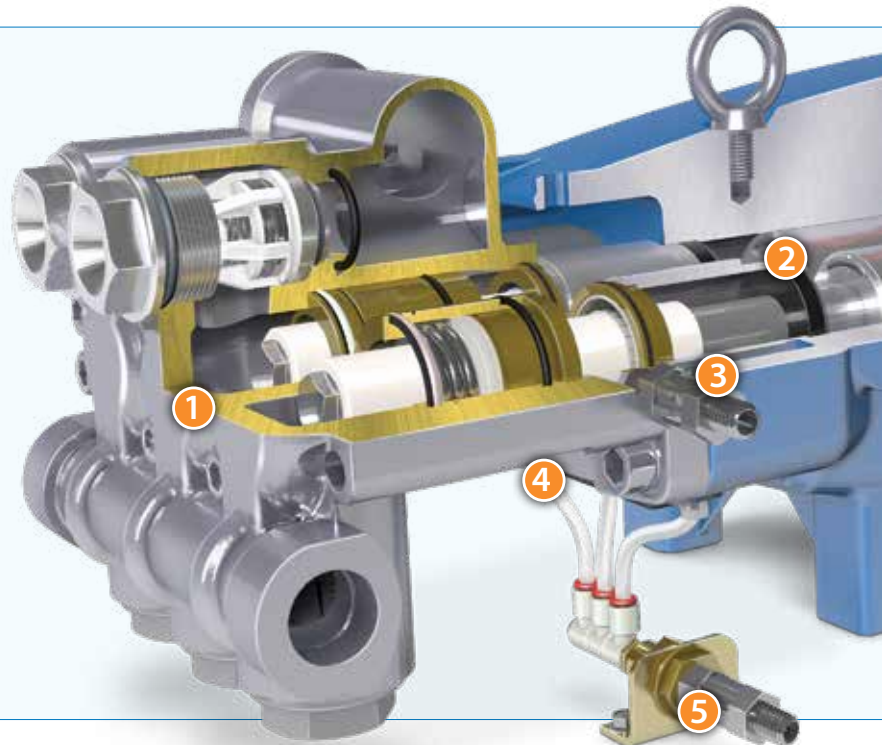

ATEX Pumps

Under the ATEX Directive, equipment is designated by group, category and zone. Cat Pumps has been certified as ATEX 2, which also covers ATEX 3 requirements.



3560 ATEX

ATEX-certified high-pressure pumps will be specially labeled and supplied with a signed ATEX Declaration of Conformity. Pumps will be numbered with the ".ATEX2" suffix added to the standard pump model number. Contact Cat Pumps for additional information.

The following pump series comply with the ATEX directive for Group 2, Category 2, and Zones 1 and 2. This Group 2 includes Zones G (1 & 2)

Pump Series

- 3CP* Plunger Pumps
- 3 Frame* Plunger Pumps
- 5CP* Plunger Pumps
- 5 Frame* Plunger Pumps
- 7CP* Plunger Pumps
- 7 Frame* Plunger Pumps
- 8 Frame* Plunger Pumps
- 15 Frame Plunger Pumps
- 18 Frame Plunger Pumps
- 25 Frame Plunger Pumps
- 28 Frame Plunger Pumps
- 35 Frame Plunger Pumps
- 38 Frame Plunger Pumps
- 60 Frame Plunger Pumps
- 68 Frame Plunger Pumps

* Excludes models equipped with gearbox

1CX Series Compact Misting Pumps

MODEL NUMBER SELECTION CHART

Pump with Electric Motor, 1250 psi Maximum Pressure



1CX w/ Motor

PUMP SERIES	FLOW (1750 RPM)	REGULATOR	ASSEMBLE OPTION	MOTOR OPTION*	PULSE HOSE OPTION
1CX	013 = .13 gpm	R = Regulator Included	D = Pump and Motor Shipped Together- Not Assembled	1 = 8180	Blank = No Pulse Hose
	025 = .25 gpm			2 = 8182	
	050 = .50 gpm		A = Pump and Motor Assembled Together	3 = 8183	P = Pulse Hose Included
				5 = 8189	

Example: 1CX050RA2P = .5 gpm, Regulator, Assembled, 8182 Motor, Pulse Hose Included

*Motor Options:

- | | |
|--|---|
| 1. 8180—¼ hp, ODP, 115/230 V, 60 Hz, 1 ph, 1750 rpm, 12 inch leads | 3. 8183—½ hp, ODP, 115/230 V, 50 Hz, 1 ph, 1450 rpm, terminal box |
| 2. 8182—½ hp, ODP, 115/230 V, 60 Hz, 1 ph, 1750 rpm, 12 inch leads | 5. 8189—½ hp, TEFC, 115/230 V, 50/60 Hz, 1 ph, 1750 rpm, terminal box |

* HP Calculation (1CX Series only): GPM x PSI ÷ 1060

NOTE: Without pulse hose amp draw will increase as much as 2 amps depending upon pump model and discharge pressure.

1XP Series Portable Extractor Pumps

1XP Pump with AC Induction Motor

- Long service life
- Dual-frequency for world-wide use
- Constant torque



AC INDUCTION MOTOR

60 Hz, 120V (1750 rpm)

GPM	MAX PSI	PUMP ASSEMBLY	SFA	HP
0.5	600	1XP050.031		
0.75	500	1XP075.031		
0.85	500	1XP085.031		
1	450	1XP100.031	4.0	½
1.25	400	1XP125.031		
1.5	325	1XP150.031		
2	250	1XP200.031		
0.4	1000	1XP050.051		
0.7	1000	1XP075.051		
0.8	1000	1XP085.051		
0.9	800	1XP100.051	8.0	½
1.2	800	1XP125.051		
1.5	600	1XP150.051		
2	450	1XP200.051		
0.9	1000	1XP100.071		
1.1	1000	1XP125.071		
1.4	800	1XP150.071	9.0	¾
1.75	700	1XP180.071		
2	550	1XP200.071		
1.45	1000	1XP150.101		
1.8	800	1XP180.101	12.6	1
2	750	1XP200.101		

AC INDUCTION MOTOR

50 Hz, 240V (1450 rpm)

GPM	MAX PSI	PUMP ASSEMBLY	SFA	HP
0.40	600	1XP050.031		
0.60	500	1XP075.031		
0.70	500	1XP085.031		
0.80	450	1XP100.031	2.1	½
1	400	1XP125.031		
1.2	325	1XP150.031		
1.70	250	1XP200.031		
0.30	1000	1XP050.051		
0.60	1000	1XP075.051		
0.70	1000	1XP085.051		
0.75	800	1XP100.051	3.8	½
1	800	1XP125.051		
1.2	600	1XP150.051		
1.70	450	1XP200.051		
0.75	1000	1XP100.071		
0.90	1000	1XP125.071		
1.20	800	1XP150.071	4.6	¾
1.50	700	1XP180.071		
1.70	550	1XP200.071		
1.20	1000	1XP150.101		
1.40	800	1XP180.101	6.3	1
1.70	750	1XP200.101		

1XP Pump with DC Permanent Magnet Motor

- Low amp draw
- Compact
- Light-weight



DC PERMANENT MAGNET

120 Volt – ½ HP – ODP and TEFC Enclosures

GPM	MAX PSI	AMPS (AT MAX PSI)	PUMP ASSEMBLY ODP MOTOR	PUMP ASSEMBLY TEFC MOTOR
0.5	600	4.0	1XP050.03DC	1XP050.03DCT
0.75	500	4.0	1XP075.03DC	1XP075.03DCT
0.85	400	4.0	1XP085.03DC	1XP085.03DCT
1	350	4.0	1XP100.03DC	1XP100.03DCT
1.25	300	4.0	1XP125.03DC	1XP125.03DCT
1.5	250	4.0	1XP150.03DC	1XP150.03DCT
2.3	150	4.0	1XP200.03DC	1XP200.03DCT

DC PERMANENT MAGNET

240 Volt – ½ HP ODP

GPM	MAX PSI	AMPS (AT MAX PSI)	PUMP ASSEMBLY ODP MOTOR
0.5	600	2.0	1XP050.03DC2
0.75	500	2.0	1XP075.03DC2
0.85	400	2.0	1XP085.03DC2
1	350	2.0	1XP100.03DC2
1.25	300	2.0	1XP125.03DC2
1.5	250	2.0	1XP150.03DC2
2.3	150	2.0	1XP200.03DC2

Centrifugal Pumps



1K SERIES—SUBMERSIBLE SUMP PUMPS

Stainless steel submersible sump pumps offer solutions to pumping semi-dirty water or fresh water with suspended solids up to $\frac{3}{8}$ ".

Flow Range	4 to 92 gpm	Operation	Manual or Automatic
Head	5 to 61 ft	Maximum Temperature	Continuous 122° F
RPM	3450 rpm		Intermittent 140° F
Discharge Fitting	1 $\frac{1}{4}$ ", 1 $\frac{1}{2}$ " NPT(F)	Maximum Solids Diameter	$\frac{3}{8}$ "
Horsepower	$\frac{1}{8}$, $\frac{1}{4}$, $\frac{3}{8}$, 1, 1 $\frac{1}{2}$ HP	Material	304 Stainless Steel



2K SERIES—SUBMERSIBLE PUMPS

Stainless steel submersible pumps offer reliable pumping of freshwater or industrial waste water with suspended solids up to 2".

Flow Range	12 to 238 gpm	Operation	Manual or Automatic
Head	4 to 74 ft	Maximum Temperature	Continuous 104° F
RPM	3450 rpm		Intermittent 140° F
Discharge Fitting	2" NPT(F)	Maximum Solids Diameter	2"
Horsepower	$\frac{1}{2}$, 1, 1 $\frac{1}{2}$, 2 HP	Material	304 Stainless Steel



3K SERIES—END-SUCTION CENTRIFUGAL PUMPS, SINGLE STAGE

Stainless steel end-suction centrifugal pumps offer dependable performance and flexibility in moving high-volume liquids at low pressure. Single stage sold as either pump kit or motorized unit.

Flow Range	5 to 105 gpm	Discharge Fitting	1" NPT(F)
Head	8 to 255 ft	Shaft Seal	Mech Type 21
Minimum Inlet Pressure to Prime	Flooded	Horsepower	$\frac{1}{8}$, $\frac{1}{4}$, $\frac{3}{8}$, 1, 1 $\frac{1}{2}$, 2, 3 HP
RPM	1725 or 3450 rpm	Maximum Temperature	160° F
Inlet Fitting	1 $\frac{1}{4}$ ", 1 $\frac{1}{2}$ " NPT(F)	Material	304 Stainless Steel



3K SERIES—END-SUCTION CENTRIFUGAL PUMPS, TWO STAGE (METRIC FRAME)

Stainless steel end-suction centrifugal pumps offer dependable performance and flexibility in moving high-volume liquids at low pressure. Sold as motorized unit only.

Flow Range	5 to 66 gpm	Discharge Fitting	1" NPT(F)
Head	127 to 255 ft	Shaft Seal	Mech Type 21
Minimum Inlet Pressure to Prime	Flooded	Horsepower	2, 3, 5 (IP 55 TEFC)
RPM	3450 RPM	Maximum Temperature	140° F
Inlet Fitting	1 $\frac{1}{4}$ ", 1 $\frac{1}{2}$ " NPT(F)	Material	304 Stainless Steel



3K SERIES—END-SUCTION CENTRIFUGAL PUMPS, TWO STAGE (NEMA FRAME)

Stainless steel end-suction centrifugal pumps offer dependable performance and flexibility in moving high volume liquids at low pressure. Sold as either pump kit or motorized unit.

Flow Range	5 to 105 gpm	Discharge Fitting	1" NPT(F)
Head	3 to 255 ft	Shaft Seal	Mech Type 21
Minimum Inlet Pressure to Prime	Flooded	Horsepower	2, 3, 5
RPM	3450 RPM	Maximum Temperature	140° F
Inlet Fitting	1 $\frac{1}{4}$ ", 1 $\frac{1}{2}$ " NPT(F)	Material	304 Stainless Steel

Centrifugal Pumps

4K SERIES—END-SUCTION CENTRIFUGAL PUMPS, SINGLE STAGE

Sold as pump kit or motorized unit.

Flow Range	5 to 633 gpm	Discharge Fitting Flange	ANSI 150 lb. – 1 ¼", 1 ½", 2", 2 ½"
Head	9 to 282 ft	Shaft Seal	Mech Type 21
Minimum Inlet Pressure to Prime	Flooded	Horsepower	1, 1 ½, 2, 3, 5, 7 ½, 10, 15, 20, 25, 30 HP
RPM	1725 or 3450 rpm	Maximum Temperature	160° F
Inlet Fitting Flange	ANSI 150 lb. – 2", 2 ½", 3"	Material	304 Stainless Steel



5K SERIES—SELF PRIMING CENTRIFUGAL PUMPS

Sold as pump kit or motorized unit.

Flow Range	2 to 18.5 gpm	Discharge Fitting	1" NPT(F)
Head	63 to 203 ft	Shaft Seal	Mech Type 21
Maximum Suction Lift	25 Feet	Horsepower	1, 2 HP
RPM	3450 rpm	Maximum Temperature	113° F
Inlet Fitting	1 ¼" NPT(F)	Material	304 Stainless Steel



6K SERIES—OPEN IMPELLER END-SUCTION CENTRIFUGAL PUMPS

Stainless steel open impeller centrifugal pumps handles suspended solids in liquid and dirty water, and handles solids up to ¾" spherical. Sold as motorized unit only.

Flow Range	25 to 290 gpm	Discharge Fitting	2" NPT(F) (with external hose barb)
Head	10 to 62 ft	Shaft Seal	Mech Type 21
Minimum Inlet Pressure to Prime	Flooded	Horsepower	1 ½, 2, 3 HP
RPM	3450 RPM	Maximum Temperature	194° F
Inlet Fitting	2", 2 ½" NPT(F)	Material	304 Stainless Steel



8K SERIES—VERTICAL MULTIPLE STAGE CENTRIFUGAL PUMPS

Stainless steel vertical multiple stage pumps designed for high volume and high ft. head clean or hot water applications. Sold as a bare pump or motorized unit (w/NEMA motor sizes).

Flow Range	3 to 607 gpm	Discharge Fitting	1 ¼" to 4" ANSI
Head	24 to 930 ft	Shaft Seal	Mechanical – Silicon Carbide / Carbon / FPM
Minimum Inlet Pressure to Prime	Flooded	Horsepower Range	½ to 60 HP
RPM	3450 RPM	Temperature Range	-22° F to 248° F
Inlet Fitting	1 ¼" to 4" ANSI	Material	304 or 316 Stainless Steel



Custom Pumping Systems

YOU DEFINE. WE DESIGN AND DELIVER.



Custom-Engineered to Meet Your Application Demands



Cat Pumps is an industry leader in providing customers with quality custom-engineered pumping systems to meet a wide range of application needs. By selecting a Cat Pumps pumping system, customers eliminate the hassle and expense of designing, multiple source buying, fabricating and testing. Our knowledgeable and helpful technical sales team assists with proper component selection as well as installation, operation and maintenance support.

All systems are designed, built and pressure tested to verify performance. To begin the quoting process, contact us at (763) 780-5440 or submit the custom system quote form at catpumps.com.

With thousands of installations running around the world, Cat Pumps is the supplier of choice for custom pumping systems.

Call or go online to start your quote today.



Custom Pumping Systems

System Configuration

With extensive experience building thousands of systems, Cat Pumps can help determine the best configuration for any application.

☑ Base

System design starts with choosing the base that best fits the application. Numerous base configurations are available to meet space, portability, sound and material demands.

- Standard • Vertically Stacked • Portable • Enclosed • Multiple Pump

☑ Power Source

A qualified technical staff with extensive experience can assist in recommending the correct product for any power source available.

- Electric • Gas • Diesel • Hydraulic • Pneumatic

☑ Drive Package

A wide variety of drive packages are available to complement any power source of choice.

- Belt • Direct-Drive • Gearbox • Flex Coupling/Bell Housing • Clutch

☑ Accessories

Choose from hundreds of high-quality genuine Cat Pumps accessories for optimum system performance and life.

- Regulator • Unloader • Relief / Pop-off Valve • Pressure Gauge
- Pulsation Dampener • Inlet Stabilizer • Inlet Filter / Strainer • Guns • Oil



Cat Pumps Advanced Control Options



Ask about the wide variety of advanced control options designed to provide maximum system performance as well as maximum system protection.

Options include:

- Variable Frequency Drives (VFD)
- PID Loop (varies speed of pump to maintain system pressure)
- Multiple Pump Systems
- Low-Pressure Seal Monitors
- Auto Shutdowns (Temperature and Low Inlet Pressure)

Other control options are available upon request.



Accessories



Demand Genuine Cat Pumps Accessories

Cat Pumps offers a wide range of high quality accessories adhering to the same exacting standards as our industry-leading pumps. Every accessory is performance tested and designed to match each pump's operating specifications. By demanding genuine Cat Pumps products, you receive the best value and lowest cost of ownership over the life of the system.

For maximum system protection, Cat Pumps recommends the use of a primary regulating device, secondary pressure relief device, and discharge pressure gauge. In addition to these system components, this catalog includes hundreds of other genuine Cat Pumps accessories. Improve system performance and protect your pumping system investment with the brand you can trust — Cat Pumps.

Maximum System Performance

Cat Pumps offers a wide range of high quality accessories adhering to the same exacting standards as our industry-leading pumps. Every accessory is performance tested and designed to match each pump's operating specifications. By demanding genuine Cat Pumps products, you receive the best value and lowest cost of ownership over the life of the system. Protect your pumping system investment with the brand you can trust — Cat Pumps.

Accessories

Typical Installation

- 1 Unloader
- 2 Regulator
- 3 Pop-Off Valve
- 4 Relief Valve
- 5 Pressure Gauge
- 6 Pulsation Dampener*
- 7 Inlet Filter
- 8 Inlet Pressure Regulator
- 9 Inlet Stabilizer
- 10 Thermal Valve
- 11 Oil Gauge/Drain Kit
- 12 Easy Start Valve

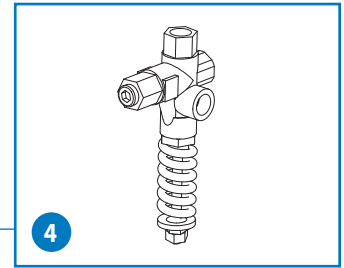
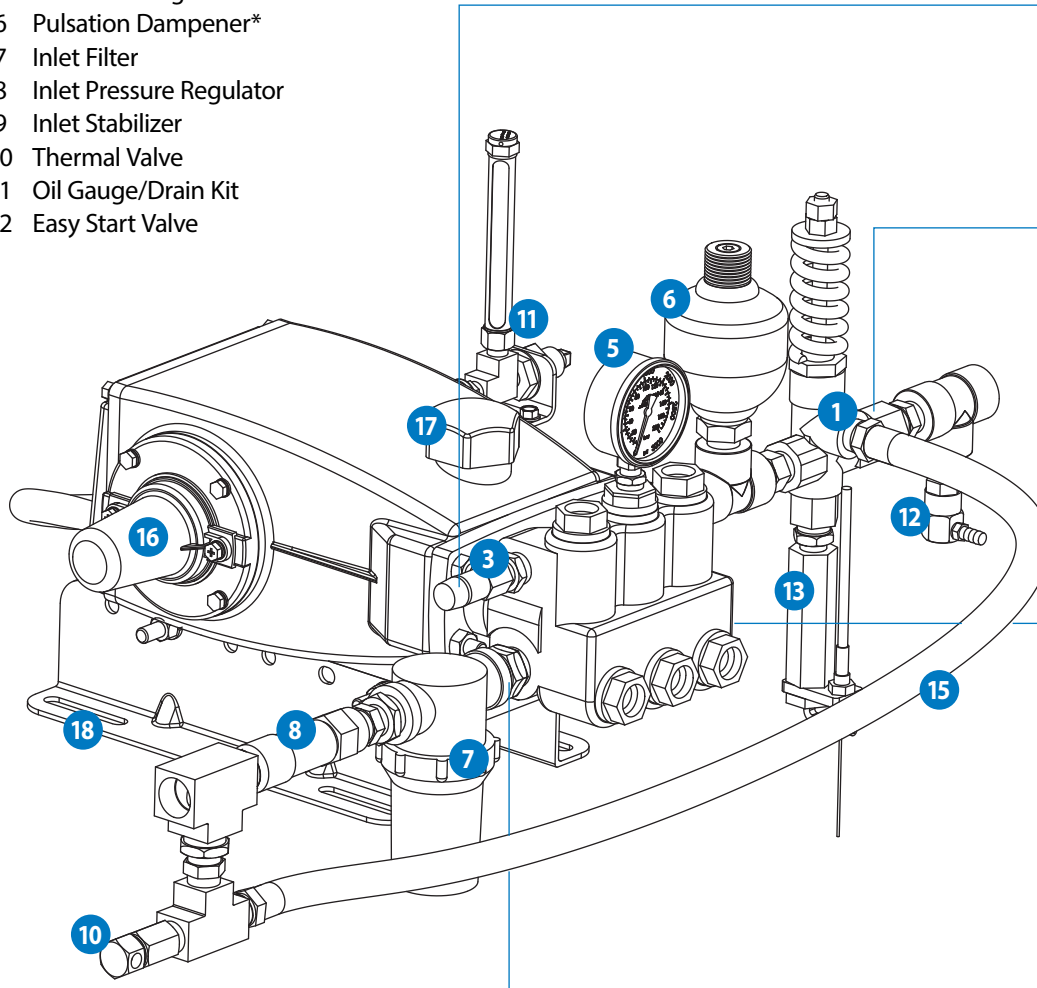

Relief Valve

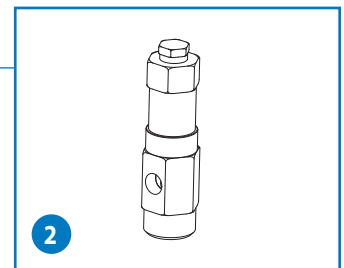

Regulator

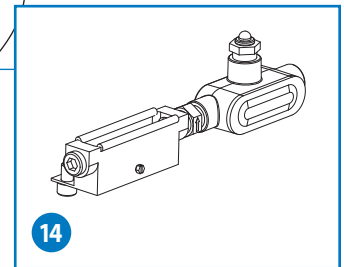

LPS Monitor

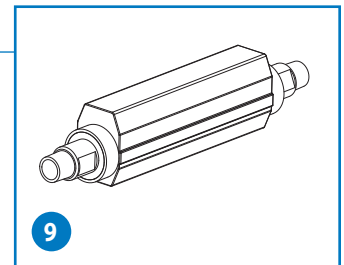

Inlet Stabilizer

- 13 Throttle Controller
- 14 LPS Monitor
- 15 Bypass Hose
- 16 Shaft Protector
- 17 Oil Cap Protector
- 18 Rails

NOTE: These illustrations show the basic elements for a typical installation of a high-pressure piston or plunger pump. **Not all components shown are required for all applications or systems.** Proper system installation, routine lubrication, monitoring and maintenance of components are basic guarantees of optimum pump performance. Cat Pumps does not assume any liability or responsibility for the design or operation of a customer's high-pressure system.

*Preferred mounting of the pulsation dampener is directly on the discharge manifold of the pump. Systems using a pressure unloader require the pulsation dampener installed down stream when the bypass is returned to the inlet of the pump and an inlet pressure regulator or check valve is used.

Discharge Accessories

Primary Pressure Control

CPC Pressure Regulators

- Cat Pumps manufactured product.
- Typically used for multiple pump, nozzle and gun applications.
- Conical design lowers minimum required bypass flow and eliminates cavitation effects, extending performance life.



STEEL NICKEL PLATED MODELS, FLOW THROUGH

Piston and Seat are 316 Stainless Steel

MODEL	FLOW RANGE		PRESSURE RANGE		PORTS	
	GPM	LPM	PSI	BAR	INLET/DISCHARGE	BYPASS
7001	0.5-5	1.9-19	100-1000	6.9-69	3/8" NPT(F)	1/2" NPT(F)
7002	0.5-5	1.9-19	500-2000	35-138	3/8" NPT(F)	1/2" NPT(F)
7003	0.5-5	1.9-19	1500-3000	103-207	3/8" NPT(F)	1/2" NPT(F)
7011	1.0-10	3.8-38	100-1000	6.9-69	1/2" NPT(F)	3/4" NPT(F)
7012	1.0-10	3.8-38	500-2000	35-138	1/2" NPT(F)	3/4" NPT(F)
7013	1.0-10	3.8-38	1500-3000	103-207	1/2" NPT(F)	3/4" NPT(F)
7014	1.0-10	3.8-38	2000-4000	138-276	1/2" NPT(F)	3/4" NPT(F)
7021	2.5-25	9.5-95	100-1000	6.9-69	3/4" NPT(F)	1" NPT(F)
7022	2.5-25	9.5-95	500-2000	35-138	3/4" NPT(F)	1" NPT(F)
7023	2.5-25	9.5-95	1500-3000	103-207	3/4" NPT(F)	1" NPT(F)
7024	2.5-25	9.5-95	2000-4000	136-276	3/4" NPT(F)	1" NPT(F)
7031	3.5-35	13.2-132	250-1000	18-69	3/4" NPT(F)	1" NPT(F)
7032	3.5-35	13.2-132	1000-2000	69-138	3/4" NPT(F)	1" NPT(F)
7033	3.5-35	13.2-132	1500-3000	103-207	3/4" NPT(F)	1" NPT(F)

316 STAINLESS STEEL MODELS, FLOW THROUGH

Piston and Seat are 316 Stainless Steel

MODEL	FLOW RANGE		PRESSURE RANGE		PORTS	
	GPM	LPM	PSI	BAR	INLET/DISCHARGE	BYPASS
7001.100	0.5-5	1.9-19	100-1000	6.9-69	3/8" NPT(F)	1/2" NPT(F)
7002.100	0.5-5	1.9-19	500-2000	35-138	3/8" NPT(F)	1/2" NPT(F)
7003.100	0.5-5	1.9-19	1500-3000	103-207	3/8" NPT(F)	1/2" NPT(F)
7011.100	1.0-10	3.8-38	100-1000	6.9-69	1/2" NPT(F)	3/4" NPT(F)
7012.100	1.0-10	3.8-38	500-2000	35-138	1/2" NPT(F)	3/4" NPT(F)
7013.100	1.0-10	3.8-38	1500-3000	105-207	1/2" NPT(F)	3/4" NPT(F)
7014.100	1.0-10	3.8-38	2000-4000	138-276	1/2" NPT(F)	3/4" NPT(F)
7720	0.5-10	1.9-38	2000-10000	138-689	1/4" NPT(F)	3/8" NPT(F)
7021.100	2.5-25	9.5-95	100-1000	6.9-69	3/4" NPT(F)	1" NPT(F)
7022.100	2.5-25	9.5-95	500-2000	35-138	3/4" NPT(F)	1" NPT(F)
7023.100	2.5-25	9.5-95	1500-3000	103-207	3/4" NPT(F)	1" NPT(F)
7024.100	2.5-25	9.5-95	2000-4000	138-276	3/4" NPT(F)	1" NPT(F)
7031.100	3.5-35	13.2-132	250-1000	18-69	3/4" NPT(F)	1" NPT(F)
7032.100	3.5-35	13.2-132	1000-2000	69-138	3/4" NPT(F)	1" NPT(F)
7033.100	3.5-35	13.2-132	1500-3000	103-207	3/4" NPT(F)	1" NPT(F)
7375	10-75	38-284	100-1000	6.9-69	1 1/4" NPT(F)	1 1/2" NPT(F)
7376	10-75	38-284	500-2000	35-138	1 1/4" NPT(F)	1 1/2" NPT(F)
7410	10-100	38-378	100-1500	6.9-103	1 1/2" NPT(F)	2" NPT(F)

316 STAINLESS STEEL MODELS, TEE MOUNT

MODEL	FLOW RANGE		PRESSURE RANGE		PORTS	
	GPM	LPM	PSI	BAR	INLET/DISCHARGE	BYPASS
7350	1.0-12	3.8-45	400-1500	25-103	1/4" NPT(F)	3/8" NPT(F)
7366	1.0-12	3.8-45	3000-6000	207-414	1/2" NPT(F)	3/4" NPT(F)
7361	10-60	38-228	400-1000	25-69	1" NPT(F)	1 1/4" NPT(F)
7363	10-60	38-228	600-1800	40-125	1" NPT(F)	1 1/4" NPT(F)

TECH TIP

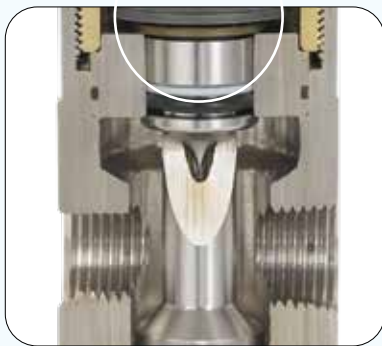

7001-7033, 7375, 7376 Series Regulators exclusively from Cat Pumps feature conical design delivering unmatched performance and life.

Features:

- Conical design lowers minimum bypass flow from 10%-5%, optimizing system performance
- Virtually eliminates cavitation effects across piston and seat, significantly extending life
- Compact in-line plumbing
- Low-pressure override provides smooth and stable operation without chatter.

Discharge Accessories

Primary Pressure Control

Unloaders, Trapped Pressure

- Typically used with trigger gun applications.
- Reduces load on pump and motor when in bypass.
- Easily converted into a relief valve.
- All trapped pressure unloaders can be configured as a relief valve.

BRASS MODELS

MODEL	FLOW RANGE		PRESSURE RANGE		PORTS	
	GPM	LPM	PSI	BAR	INLET/DISCHARGE	BYPASS
7500S	0.5–6.0	1.9–23	100–2000	6.9–138	3/8" NPT(M)	3/8" NPT(F)
7581	0.5–6.6	1.9–25	232–2320	16–160	3/8" NPT(M)	3/8" NPT(F)
7582	0.5–8.0	1.9–30	100–1000	6.9–69	3/8" NPT(M)	3/8" NPT(F)
7583	0.5–8.0	1.9–30	250–2000	18–138	3/8" NPT(M)	3/8" NPT(F)
7620	0.5–8.0	1.9–30	319–3190	22–220	3/8" BSP(M)/BSP(F)	3/8" BSP(F)
7600S	2.0–5.0	8–19	700–3500	6.9–241	3/8" NPT(M)	3/8" NPT(F)
7630	2.0–10.5	7.6–40	507–5076	35–350	3/8" BSPP(M)/BSPP(F)	1/2" BSPP(F)
7693	2.5–10.5	9.5–40	232–2320	16–158	3/8" NPT(F)	3/8" NPT(F)
7694	2.5–10.5	9.5–40	406–4060	28–280	3/8" NPT(F)	3/8" NPT(F)
7537	1.0–21	3.8–80	406–2320	28–160	1/2" NPT(F)	1/2" NPT(F)
7542	1.0–21	3.8–80	406–4060	28–280	1/2" NPT(F)	1/2" NPT(F)
7590	10–52.8	38–200	218–2175	15–150	1" NPT(F)	1" NPT(F)
7592	10–52.8	38–200	450–2500	31–172	1" NPT(F)	1" NPT(F)
7593	10–52.8	38–200	406–4060	28–280	1" BSPP(F)	1" BSPP(F)
9950	50–120	190–456	290–2900	20–200	1 1/4" BSPP(F)	1 1/2" BSPP(F)



BRASS, MODULAR, BUILT-IN BYPASS, 3CP, 5CP AND 66 DX SERIES

Pressure-Sensitive

MODEL	FLOW RANGE		PRESSURE RANGE		PORTS	
	GPM	LPM	PSI	BAR	INLET/DISCHARGE	MODELS
7850*	0.5–6.0	1.9–23	100–4000	6.9–276	1/2" NPT(F)/3/8" NPT(M)	3CP, 5CP
7860	3.0–5.0	11.4–19.0	700–4000	50–276	1/2" NPT(F)/3/8" NPT(M)	66DX Series
7861	3.0–5.0	11.4–19.0	700–4000	50–276	1/2" NPT(F)/3/8" NPT(M)	66DX40DSG1
7865	0.5–6.0	1.9–23	100–4000	6.9–276	1/2" NPT(F)/3/8" NPT(M)	5CP4116–5CP4120CSS
7866	0.5–6.0	1.9–23	100–4000	6.9–276	1/2" NPT(F)/3/8" NPT(M)	5CP4110–5CP4114CSS
7867	0.5–6.0	1.9–23	100–4000	6.9–276	1/2" NPT(F)/3/8" NPT(M)	5CP4110–5CP4120CSS

* This unloader will not work on models 5CP4120, 5CP6120, 5CP6180CSS and 5CP6190 pumps.

STAINLESS STEEL MODELS

MODEL	FLOW RANGE		PRESSURE RANGE		PORTS	
	GPM	LPM	PSI	BAR	INLET/DISCHARGE	BYPASS
7501**	0.5–6.0	1.9–23	100–2000	6.9–138	3/8" NPT(M)	3/8" NPT(F)
9970*	0–15.9	0–60	1160–11600	80–800	1/2" BSPP(G)	1/2" BSPP(G)
7531*	1.0–21	3.8–80	218–2175	15–150	1/2" NPT(F)	1/2" NPT(F)
7533*	1.0–21	3.8–80	406–4060	28–280	1/2" NPT(F)	1/2" NPT(F)
7536*	1.0–21	3.8–80	580–5800	40–400	1/2" NPT(F)	1/2" NPT(F)

* 304 Stainless Steel ** 316 Stainless Steel

TECH TIP

Regulating Unloader to Relief Valve Conversion

Pressure-Sensitive Regulating Unloaders are typically used as a primary pressure regulating device. They can be converted to a Relief Valve to be used as a secondary pressure relief device by removing the discharge check valve, O-ring and spring.

EXAMPLE:

Unloader PN	Modifications
7537	Remove parts 441, 443, 444

Converted Relief Valve PNs

7537.100 (NBR Seals)	7537.1110 (FPM Seals)
----------------------	-----------------------

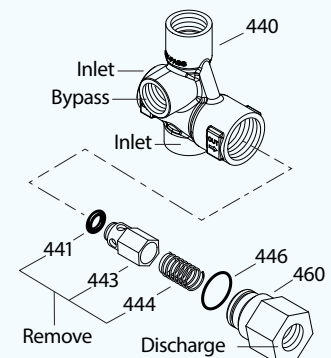

Discharge Accessories

Primary or Secondary Pressure Control

Pressure Relief Valves

- Heavy duty; conveniently mounts directly into discharge line.
- Wide pressure and flow range models available.



BRASS MODELS

MODEL	FLOW RANGE		PRESSURE RANGE		PORTS	
	GPM	LPM	PSI	BAR	INLET/DISCHARGE	BYPASS
7189	0.5–6.6	1.9–24.9	100–650	6.9–45	3/8" NPT(F)	3/8" NPT(F)
7190	0–6.5	0–24.6	400–5000	28–345	3/8" BSP(F)	3/8" BSP(F)

316 STAINLESS STEEL MODELS, FLOW THROUGH

MODEL	FLOW RANGE		PRESSURE RANGE		PORTS	
	GPM	LPM	PSI	BAR	INLET/DISCHARGE	BYPASS
7034	0–21	0–80	400–2200	28–155	1/2" NPT(F)	1/2" NPT(F)
7036	0–21	0–80	800–4000	55–276	1/2" NPT(F)	1/2" NPT(F)
7037	0–21	0–80	3000–5700	207–400	1/2" NPT(F)	1/2" NPT(F)
890718	10–50	38–189	1000–8000	69–550	2" NPT(M)	2" NPT(F)
890709	20–60	76–227	1500–4000	103–276	2" NPT(F)	2" NPT(M)
890731	15–75	56–284	100–400	6.9–28	2" NPT(F)	2" NPT(M)
890700	30–180	114–680	1000–3000	69–207	2" NPT(F)	2" NPT(M)
890702	25–210	95–795	500–2000	35–138	2" NPT(F)	2" NPT(M)
890706	15–260	57–984	250–1000	17–69	2" NPT(F)	2" NPT(M)
890704	45–320	170–1211	500–2000	35–138	2" NPT(F)	2" NPT(M)

Note: All trapped pressure unloaders can be configured as a relief valve, see page 25.

BRASS MODELS, TEE MOUNT

MODEL	FLOW RANGE		PRESSURE RANGE		PORTS	
	GPM	LPM	PSI	BAR	INLET/DISCHARGE	BYPASS
7561	0–4.0	0–15.1	100–1250	6.9–86	1/4" NPT(M)/NPT(F)	1/4" NPT(F)
7080	0–8.0	0–30	150–1450	10–100	3/8" NPT(F)	3/8" NPT(F)
7082	0–8.0	0–30	320–3200	22–220	3/8" NPT(F)	3/8" NPT(F)
997304	0–20	0–75.7	0–300	0–20	1/2" NPT(M)	1/2" NPT(F)
7196	0–21	0–80	100–7250	6.9–500	1/2" BSP(F)	3/8" BSP(F)
7084*	1.0–3.5	3.8–13	100–600	6.9–41	1/4" BSP(M)	1/8" BSP(F)
7085*	1.0–3.5	3.8–13	205–2300	14–158	1/4" BSP(M)	1/8" BSP(F)
7595	1.0–53	3.8–200	260–2600	18–180	3/4" NPT(F)	1/2" NPT(F)

* Model 7084C & 7085C available with handles

TECH TIP

Regulator vs. Unloader Valve Product Comparison

This product comparison video from Cat Pumps offers an in-depth look at one of our most common inquiries — the difference between the pressure regulator and pressure regulating unloader valve.



www.youtube.com/watch?v=PJO8U7fq7_s&t=3s



Discharge Accessories

Secondary Pressure Control

Pop-Off Valves

- Opens when system exceeds preset pressure.
- Lightweight, compact design quickly and conveniently mounts directly into discharge line.
- Ultra compact models for portable systems.

BRASS MODELS

MODEL	MAX FLOW		PRESSURE RANGE		MAX RELIEF SETTING		PORTS	
	GPM	LPM	PSI	BAR	PSI	BAR	INLET/DISCHARGE	BYPASS
30960	6.0	23	300–1500	20–103	1650	114	¼" NPT(M)	¾" Barb
33960	6.0	23	300–1500	20–103	1650	114	¾" NPT(M)	¾" Barb
33960S*	6.0	23	300–1500	20–103	1650	114	¾" NPT(M)	¾" Barb
30961	6.0	23	1000–3000	69–207	3300	228	¼" NPT(M)	¾" Barb
33961	6.0	23	1000–4000	69–276	4400	303	¼" NPT(M)	¾" Barb
33961S*	6.0	23	1000–4000	69–276	4400	303	¼" NPT(M)	¾" Barb
33962	6.0	23	1000–4000	69–276	4400	303	¾" NPT(M)	¾" Barb
33962S*	6.0	23	1000–4000	69–276	4400	303	¾" NPT(M)	¾" Barb
9940	25	95	1000–4000	69–276	4400	303	¾" NPT(M)	1" Barb

* High-temperature models up to 240° F (115° C)



316 STAINLESS STEEL MODELS

MODEL	MAX FLOW		PRESSURE RANGE		MAX RELIEF SETTING		PORTS	
	GPM	LPM	PSI	BAR	PSI	BAR	INLET/DISCHARGE	BYPASS
9960	6.0	23	300–1500	20–103	1650	114	¼" NPT(M)	¾" Barb
9960S*	6.0	23	300–1500	20–103	1650	114	¼" NPT(M)	¾" Barb
9961	6.0	23	1000–3000	69–207	3300	228	¼" NPT(M)	¾" Barb
9961S*	6.0	23	1000–3000	69–207	3300	228	¼" NPT(M)	¾" Barb
9962	6.0	23	1000–4000	69–276	4400	308	¼" NPT(M)	¾" Barb
9962S*	6.0	23	1000–4000	69–276	4400	308	¼" NPT(M)	¾" Barb
997587	15	57	1500–10000	105–689	11000	758	½" NPT(F)	1" NPT(F)
9941	25	95	1000–4000	69–276	4400	303	¾" NPT(M)	1" Barb
890711	50	189	1000–6000	69–414	7500	517	1" NPT(M)	1" NPT(F)
890710	100	378	300–1500	20–103	1875	129	1" NPT(M)	1" NPT(F)
890714**	100	378	300–1500	20–103	1875	129	1" NPT(M)	1" NPT(F)
890715	100	378	1000–8000	69–550	10000	689	2" NPT(M)	2" NPT(F)
890712	115	435	500–3000	35–207	3750	258	1" NPT(M)	1" NPT(F)
890703	135	511	400–1500	28–103	1875	129	2" NPT(M)	2" NPT(F)
890713	210	795	800–4000	55–276	5000	345	2" NPT(M)	2" NPT(F)

* High-temperature models up to 240° F (115° C) **NBR O-Rings



RUPTURE DISC ASSEMBLY

MODEL	MAX FLOW		MAX RELIEF SETTING		PORTS	
	GPM	LPM	PSI	BAR	INLET	RELIEF
9921	20	76	10000	689	¾" NPT(M)	¾" NPT(F)
9920	20	76	15000	1034	¾" NPT(M)	¾" NPT(F)

TECH TIP

www.catpumps.com/troubleshooting-tips-pop-off-valves



Primary and Secondary Relief

Cat Pumps strongly recommends equipping each high-pressure pumping system with primary and secondary safety relief devices to safeguard against over-pressurization. These cost-effective measures help to protect the system from failure, preventing damage to expensive components and minimizing costly downtime. Check out our new Troubleshooting Tips video for critical information on why and when to use a pop-off valve and how to set their pressure properly.



Discharge Accessories



Pressure Gauges

Accurately monitors pump outlet pressure.

- Glycerine-filled for consistent and accurate pressure readings.
- Sealed stainless steel case eliminates corrosion risk.

MODEL	PRESSURE RANGE		MAXIMUM TEMPERATURE		PORTS INLET
	PSI	BAR	(° F)	(° C)	

BRASS MODELS (BRASS FITTING AND BOURDON TUBE, 304 SS CASE)

6091	0-1000	0-69	160	71	¼" NPT(M)
6092**	0-1000	0-69	160	71	¼" NPT(M)
6086	0-1500	0-103	140	60	¼" NPT(M)
991728**	0-1500	0-103	140	60	⅜" NPT(M)
6088	0-3000	0-207	140	60	¼" NPT(M)
6096**	0-3000	0-207	140	60	⅜" NPT(M)
6089	0-6000	0-415	140	60	¼" NPT(M)

STAINLESS STEEL MODELS (316 SS FITTING AND BOURDON TUBE, 304 SS CASE)

6069	0-600	0-41	200	93	¼" NPT(M)
6071	0-1500	0-103	300	149	¼" NPT(M)
6085	0-1500	0-103	140	60	¼" NPT(M)
6073	0-3000	0-207	300	149	¼" NPT(M)
6097	0-3000	0-207	140	60	¼" NPT(M)
6127	0-4000	0-276	140	60	½" NPT(M)
6076	0-6000	0-415	300	149	¼" NPT(M)
6087	0-6000	0-415	140	60	¼" NPT(M)
6081*	0-20000	0-1379	212	100	½" NPT(M)

* Black polyester case ** Back Mount



34549

Valve Plug Adapters

Used to add an accessory to discharge port

- Replaces one top valve plug with a ported valve plug to add a pressure gauge, pop-off valve or other accessory.
- Eliminates the need for additional plumbing on the discharge port.

MODEL	MODELS USED	PORT	MATERIAL
35759	1DX, 2DX, 3DX	¼" NPT (F)	BB
35761	2DX, 3DX	⅜" NPT (F)	BB
134670	3DNX, 3SP, 3SPX, 4DX, 4DNX, 4SP, 4SPX, 5SP	¼" NPT (F)	BB
35758	66DX Series	⅜" NPT (F)	BB
998954	3CP Series, 310-350, 5CP2100 Series	⅜" NPT (F)	BB
34549	45, 5CP3105-3160CSS, 5CP5120-5CP5140	⅜" NPT (F)	BB
45939T	56-60	⅜" NPT (F)	BB
34447	7PFR, 15PFR, 5CP6120, 5CP6180CSS, 7CP	⅜" NPT (F)	BB
43848	1530, 1530C, 1730	½" NPT (F)	FBB
76795	3507HS, 3517HS	¼" NPT (F)	NAB
997878	3560	¼" NPT (F)	BB
76678	3527HS, 3537HS, 3547HS, 3570, 3570C, 3570S	¼" NPT (F)	NAB
76461	6760, 6775	¼" NPT (F)	NABC

Quick Disconnect Assemblies

Used to connect discharge hose to discharge hose.

- Straight-through flow design or double shut-off.

MODELS	MATERIAL	MAXIMUM		PORT
		PSI	BAR	
990469	Brass	2000	138	½" NPT(F) x ½" NPT(F)
34380	Brass	4000	276	⅜" NPT(F) x ⅜" NPT(F)
34381	Steel	10000	689	½" NPT(F) x ½" NPT(F)
34382	Steel	3000	207	¾" NPT(F) x ¾" NPT (F)
34384	Steel	4000	276	½" NPT(F) x ½" NPT (F)



34380

Discharge Accessories

Pulsation Dampeners

Used when a smooth output flow and pressure are required.

- Pressurized bladder absorbs impact from pressure spikes, providing smoother flow.
- Most models are field repairable and rechargeable.

MODEL	MAXIMUM FLOW		PRESSURE RANGE		BLADDER MATERIAL	VOLUME CUBIC INCHES	PRECHARGE PSI	PORT INLET
	GPM	LPM	PSI	BAR				
CARBON STEEL (UPPER BODY), 316 STAINLESS STEEL (LOWER BODY) RECHARGEABLE								
6029	15	57	100–3000	6.9–207	NBR	10	450	½" NPT(M)
6030	15	57	100–3000	6.9–207	FPM	10	450	½" NPT(M)
6011*	25	95	100–7200	6.9–500	NBR	15	2000	½" NPT(F)
6018	40	151	100–3000	6.9–207	NBR	45	450	1" NPT(M)
6022	70	265	100–1500	6.9–103	NBR	120	450	1¼" NPT(M)

* Carbon Steel upper and lower body

CARBON STEEL, SEALED

6026	15	57	300–600	20–41	NBR	10	250	½" NPT(M)
6028	15	57	600–1000	41–69	NBR	10	450	½" NPT(M)

316 STAINLESS STEEL, RECHARGEABLE

6032	10	37.8	100–10000	6.9–689	NBR	15	6000	½" NPT(F)
6031	15	57	100–2400	6.9–168	NBR	10	450	½" NPT(M)
6014	25	95	100–2400	6.9–168	NBR	20	450	¾" NPT(M)
6016	40	151	100–2000	6.9–138	NBR	45	450	1" NPT(M)
6013	40	151	100–2000	6.9–138	FPM	45	450	1" NPT(M)
6015	70	265	100–1500	6.9–103	NBR	120	450	1¼" NPT(M)

316 STAINLESS STEEL, RECHARGEABLE AND REBUILDABLE

701501	15	57	100–4300	6.9–296	NBR	6	N/A	½" NPT(F)
701521	15	57	100–4300	6.9–296	EPDM	6	N/A	½" NPT(F)
701541	15	57	100–4300	6.9–296	FPM	6	N/A	½" NPT(F)
701520	15	57	100–8300	6.9–572	NBR	6	N/A	½" NPT(F)
701535	15	57	100–8300	6.9–572	FPM	6	N/A	½" NPT(F)
701502	25	95	100–3800	6.9–265	NBR	15	N/A	½" NPT(F)
701542	25	95	100–3800	6.9–265	FPM	15	N/A	½" NPT(F)
701522	25	95	100–3800	6.9–265	EPDM	15	N/A	½" NPT(F)
701507	25	95	100–7100	6.9–490	NBR	15	N/A	½" NPT(F)
701537	25	95	100–7100	6.9–490	FPM	15	N/A	½" NPT(F)
701527	25	95	100–7100	6.9–490	EPDM	15	N/A	½" NPT(F)
701610	25	95	100–10,000	6.9–689	NBR	15	N/A	½" NPT(F)
701503	75	284	100–3000	6.9–207	NBR	30	N/A	1" NPT(F)
701543	75	284	100–3000	6.9–207	FPM	30	N/A	1" NPT(F)
701523	75	284	100–3000	6.9–207	EPDM	30	N/A	1" NPT(F)
701550	100	378	100–3365	6.9–232	NBR	122	N/A	1½" NPT(F)
701555	100	378	100–6350	6.9–438	NBR	60	N/A	1" NPT(F)
701557	320	1211	100–1275	6.9–88	NBR	214	N/A	1½" NPT(F)

Pulsation Dampener Ordering Information

For optimal performance, pulsation dampener precharge should be set accordingly:

- Rechargeable (6011–6031) should be preset at 50% of the operating pressure
- Rebuildable (701501–701610) should be preset to 75% of the operating pressure

To change the preset precharge, add a .800 to the part number and specify precharge pressure.



TECH TIP

Due to the design of positive displacement pumps, small pressure spikes are caused during each rotation. In certain operations, these spikes can cause accelerated wear or damage to the pump or downstream components. The installation of a pulsation dampener is the best practice to reduce pressure fluctuations.

Model 1530 w/o Pulsation Dampener

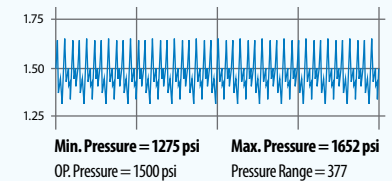

Model 1530 w/ Pulsation Dampener

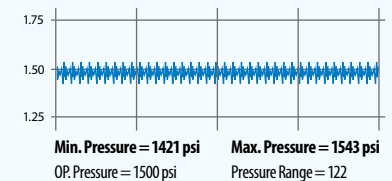

Pulsation Dampener Benefits:

- Produces smooth, consistent flow
- Protects downstream components (e.g., regulator, unloader, relief valve)
- Reduces water hammer
- Improved performance at low rpm

Inlet Accessories



Filters

Used to filter solid particulates in water.

- Flow from inside-to-outside allows sediment to collect inside the removable filter screen.
- Removable bowl permits easy cleaning without removing filter or plumbing.

MODEL	SUCTION/ PRESSURIZED FLOW		SCREEN		PORTS	
	GPM	LPM	MESH	MATERIAL	INLET	DISCHARGE

WHITE NYLON BODY

7104*	6/10	23/38	80	S	½" NPT(F)	½" NPT(F)
7105*	15/20	57/76	80	S	¾" NPT(F)	¾" NPT(F)
7106*	20/25	76/95	80	S	1" NPT(F)	1" NPT(F)
7107*	35/50	133/189	80	S	1¼" NPT(F)	1¼" NPT(F)
7108*	60/75	227/284	80	S	1½" NPT(F)	1½" NPT(F)

CLEAR NYLON BODY

7104.4*	6/10	23/38	80	S	½" NPT(F)	½" NPT(F)
7105.5*	15/20	57/76	80	S	¾" NPT(F)	¾" NPT(F)
7106.6*	20/25	76/95	80	S	1" NPT(F)	1" NPT(F)
7107.7*	35/50	133/189	80	S	1¼" NPT(F)	1¼" NPT(F)
7108.8*	60/75	227/284	80	S	1½" NPT(F)	1½" NPT(F)

POLYPROPYLENE BODY (Y-INLINE)

7109	100/150	378/567	80	SS	2" NPT(F)	2" NPT(F)
------	---------	---------	----	----	-----------	-----------

WHITE NYLON BODY (MICRO)

7203	10 gpm max	38	80	S	½" NPT(M)	½" NPT(M)
7204	10 gpm max	38	80	S	½" NPT(F)	½" NPT(F)

CLEAR NYLON BODY (MICRO)

7203.3	10 gpm max	38	80	S	½" NPT(M)	½" NPT(M)
7204.4	10 gpm max	38	80	S	½" NPT(F)	½" NPT(F)

REINFORCED COMPOSITE BODY (W/ BRASS THREADED PORTS, ¼" BSP(F) AUXILIARY PORT)

32738	8 gpm max	30	50	SS	½" BSP(F)	½" BSP(M)
32748	8 gpm max	30	50	SS	½" BSP(F)	½" BSP(F)

S = 304 Stainless steel, SS = 316 Stainless steel Optional Mesh sizes available

* For suction applications refer to Data Sheets for inlet pressure losses vs. flow to prevent cavitation.

Inlet Pressure Gauges

Accurately monitors pump inlet pressure.

- Glycerine-filled for consistent and accurate pressure readings.
- Sealed stainless steel case eliminates corrosion risk.



MODEL	MAXIMUM PRESSURE		TEMPERATURE RANGE		PORTS INLET
	PSI	BAR	(° F)	(° C)	

BRASS MODELS (BRASS FITTING AND BOURDON TUBE, 304 SS CASE)

6082	100	6.9	30–160	-1.1–71	¼" NPT(M) Bottom
997901	400	28	0–150	-17–65	¼" NPT(M) Bottom

STAINLESS STEEL MODELS (316 SS FITTING AND BOURDON TUBE, 304 SS CASE)

997068*	160	11	-4–140	-20–60	¼" NPT(M) Bottom
997336	160	11	0–140	-17–60	¼" NPT(M) Panel Mount
994063*	400	28	0–210	-17–98	½" NPT(M) Bottom

* Black polyester case

Note: Maximum inlet pressure is 70 psi on most pumps. Review pump data sheet.

Inlet Accessories

Inlet Pressure Regulators

Used to set and maintain consistent pressure at pump inlet.

- Convenient, compact in-line installation.
- Adjustable and non-adjustable models available.
- Improves pump performance.

MODEL	MAXIMUM FLOW		INLET PRESSURE		OUTLET PRESSURE		PORTS	
	GPM	LPM	PSI	BAR	PSI	BAR	INLET	OUTLET
BRASS – NONADJUSTABLE								
7069	10	38	40–200	3–14	30–45	2–3	¾" FGH	¾" MGH
7071	10	38	40–200	3–14	30–45	2–3	¾" FGH	½" NPT(F)
STAINLESS STEEL – ADJUSTABLE								
7SS075	0–12	0–45	350	24	15–85	1.03–5.86	¾" NPT(F)	¾" NPT(F)
7SS100	0–20	0–76	350	24	15–85	1.03–5.86	1" NPT(F)	1" NPT(F)
7SS150	0–50	0–189	350	24	15–85	1.03–5.86	1½" NPT(F)	1½" NPT(F)
7SS200	0–75	0–284	350	24	15–85	1.03–5.86	2" NPT(F)	2" NPT(F)



Inlet Pressure Relief Valves

Protects the inlet line from overpressurization.

- Simple preset design to protect from excessive inlet pressure or pressure spikes.
- Built for convenient compact installation.

MODEL	FLOW RANGE		RELIEF PRESSURE		PORTS	
	GPM	LPM	PSI	BAR	INLET	BYPASS
BRASS						
7420	0–10	0–37.8	125	8.6	½" NPT(M)	½" NPT(F)
STAINLESS STEEL						
7421	0–10	0–37.8	75	5.2	½" NPT(M)	½" NPT(F)



Inlet Pressure Stabilizers

Used to maintain consistent inlet pressure.

- Eliminates cavitation and potentially damaging surges and hydraulic spikes.
- Compact, easy installation with matching adapter assemblies.

MODEL	MAXIMUM FLOW		INLET PRESSURE RANGE		PORTS ADAPTER SIZES AVAILABLE
	GPM	LPM	PSI	BAR	
STAINLESS STEEL					
711500	16	60	2.0–50	0.1–3.5	½", ¾", 1", 1¼", 1½"
714500	45	170	2.0–50	0.1–3.5	1", 1¼", 1½", 2", 2½"
717500	75	284	2.0–50	0.1–3.5	2", 2½"
719500	320	1211	2.0–60	0.1–4.1	6" X ANSI 150, 6" R150 Series Flange

FITTING SIZE	INLET STABILIZERS			
	711500	714500	717500	719500
STRAIGHT ADAPTER FITTINGS				
½" NPT(M)	711502			
¾" NPT(M)	711503			
1" NPT(M)	711504	714504		
1¼" NPT(M)	711505	714505		
1½" NPT(M)	711506	714506		
2" NPT(M)		714508	717508	
2½" NPT(M)			717510	
ELBOW ADAPTER FITTINGS				
1½"	701818			
2½"		701828		
3"			701833	
6"				719529



Inlet Accessories



Thermal Valves

Reduces heat build-up in a closed-loop bypass system.

- Lightweight with three port size options for easy installation.
- Recommended when bypass is redirected to pump inlet.

MODEL	TEMPERATURE F°	PORTS		MAXIMUM FLOW		MAXIMUM PRESSURE	
		INLET	BLEED	GPM	LPM	PSI	BAR

BRASS MODELS

7140	145	¼" NPT(M)	⅛" NPT(F)	25	95	125	8.6
7141	145	⅜" NPT(M)	⅛" NPT(F)	25	95	125	8.6
7142	145	½" NPT(M)	⅛" NPT(F)	25	95	125	8.6
7143	165	¼" NPT(M)	⅛" NPT(F)	25	95	125	8.6
7144	165	⅜" NPT(M)	⅛" NPT(F)	25	95	125	8.6
7145	165	½" NPT(M)	⅛" NPT(F)	25	95	125	8.6
7146	130	¼" NPT(M)	⅛" NPT(F)	25	95	125	8.6
7170	180	¼" NPT(M)	⅛" NPT(F)	25	95	125	8.6
7171	180	⅜" NPT(M)	⅛" NPT(F)	25	95	125	8.6
7172	180	½" NPT(M)	⅛" NPT(F)	25	95	125	8.6
7175	190	¼" NPT(M)	⅛" NPT(F)	25	95	125	8.6
7176	190	⅜" NPT(M)	⅛" NPT(F)	25	95	125	8.6
7177	190	½" NPT(M)	⅛" NPT(F)	25	95	125	8.6

BRASS-MICRO MODELS

7116	145	⅜" BSP(M)	7 mm	25	95	145	10.0
------	-----	-----------	------	----	----	-----	------

REINFORCED COMPOSITE MODELS

7128	165	¼" NPT(M)	⅛" NPT(F)	25	95	125	8.6
7129	165	⅜" NPT(M)	⅛" NPT(F)	25	95	125	8.6
7130	165	½" NPT(M)	⅛" NPT(F)	25	95	125	8.6
7135	145	¼" NPT(M)	⅛" NPT(F)	25	95	125	8.6
7136	145	⅜" NPT(M)	⅛" NPT(F)	25	95	125	8.6
7137	145	½" NPT(M)	⅛" NPT(F)	25	95	125	8.6
7138	130	¼" NPT(M)	⅛" NPT(F)	25	95	125	8.6

Garden Hose Assemblies

Used to connect garden hose to pump inlet port.

- Convenient swivel for easy inlet connection.
- Inlet screen for filtering.



MODELS	MATERIAL	USED ON PUMP MODELS	PORT
941516	Brass	2SF, 2SFX, 4DX, 4DNX, 4SP, 4SPX Series	⅜" NPT(M)
941517	Brass	3CP, 5CP, 5SP, 66DX, 67DX Series	½" NPT(M)

Specialty Accessories

Easy Start Valve

Designed to relieve pump discharge line pressure during system start-up.

- Use with a pressure-sensitive regulating unloader (install after unloader).
- Requires less engine or motor start-up power.

MODEL	MAXIMUM FLOW		MAXIMUM PRESSURE		OPENING PRESSURE		INLET PORT	BARB
	GPM	LPM	PSI	BAR	PSI	BAR		
7126	8.0	30	4050	280	105	7.25	3/8" NPT(M)	1/4"



7126

Throttle Control

Reduces engine wear and fuel consumption by lowering rpm when pump is in bypass.

- Can be used on any size gas engine.
- Used with pressure-sensitive regulating unloaders.

MODEL	MAXIMUM PRESSURE		ACTUATION PRESSURE		INLET PORT
	PSI	BAR	PSI	BAR	
8100	4000	276	250	18	3/8" NPT(M)



8100

Mag-Jet and Pulsator Assemblies

Converts water-pressure pump to a water-jetting pump.

- Eliminates traditional dry pumping chamber that causes damage to pump.
- Easily mounts in the manifold inlet plug on most Cat Pumps models.

MODEL	USED ON PUMP MODELS
-------	---------------------

MAG-JET ASSEMBLIES

31804	3CP1110CS, 3CP1120, 3CP1120G, 3CP1130, 3CP1140
31810	56, 56G1, 56G118, 56HS, 56HSG1, 56HSG11857, 60, 60G1, 60G118
31814	310, 340, 350, 5CP2120W, 5CP2140WCS, 5CP2150W
31815	45, 45G1, 5CP3120, 5CP3120CSS, 5CP3120CSSG1, 5CP5120, 5CP5120CSS, 5CP5135CSS, 5CP5135CSSG1, 5CP5140, 5CP5140CSS, 5CP5140CSSG1, 5CP5140CSSG118
31845	530, 550, 660, 1050, 5CP6120, 5CP6120CSSG1, 7CP6110CS, 7CP6110CSG1, 7CP6160CS, 7CP6160CSG1, 7CP6165CSG1, 7CP6170, 7CP6170G1, 7CP6185CS

PULSATOR ASSEMBLIES

34455	2SFX Series Pumps
76560	1560
35450	66DX Series
34451	56, 56HG1, 56G118, 56HS, 56HSG1, 56HSG117, 57, 60, 60G1, 60G118
34458	45, 5CP3120, 5CP3120CSS, 5CP3120CSSG1, 5CP5120, 5CP5120CSS, 5CP5140, 5CP5140CSS, 5CP5140CSSG1, 5CP5140CSSG118
34448	660, 1050, 7CP6110CS, 7CP6110CSG1, 7CP6160CS, 7CP6160CSG1, 7CP6165CSG1, 7CP6170, 7CP6170G1, 7CP6185CS
77071	2510



31845

76560

Specialty Accessories

12VAUTO80
Auto Shutoff
Control



Auto Shut-Off Assemblies

Used to automatically shut system off when trigger gun is released or nozzle is closed.

- Assembly includes a pair of pressure switches, mechanical relay, electrical box and toggle switch.
- Higher horsepower units use a magnetic motor starter and overload heaters.

MODEL	HORSEPOWER/ PHASE	VOLTAGE	PRESSURE SWITCH MODELS	MECHANICAL RELAY MODEL	STARTER
34870	2/1	115	31615, 31625	34542	NA
34871	3/1	220	31615, 31625	34543	NA
12VAUTO80	1/DC	12	31615, 31625	76593	NA



34870

LPS Monitors

Designed to sense water leakage past the low-pressure seals.

- Can configure the monitor to PLC or PC based systems.
- Light option to alert maintenance personnel when pump seal replacement is required.



30664.120VAC

MODEL	USED ON PUMP MODELS
-------	---------------------

PLC/PC INTERFACE FOR 15 AND 18 FRAME PLUNGER PUMPS

30664	Plunger pumps: 650 thru 1810K
-------	-------------------------------

INDICATOR LIGHT FOR 15 AND 18 FRAME PLUNGER PUMPS

30664.120AC, 30664.240AC	Plunger pumps: 650 thru 1810K
-----------------------------	-------------------------------

PLC/PC INTERFACE FOR 25 FRAME PISTON, 25, 28, 35 AND 38 FRAME PLUNGER PUMPS

30290, 30292	Piston pump: 2520 Plunger pumps: 2530 thru 2831K, 3501HS thru 3570, 3801HS thru 3841KHS
--------------	---

INDICATOR LIGHT FOR 25 FRAME PISTON, 25, 28, 35 AND 38 FRAME PLUNGER PUMPS

30290.120AC	Piston pump: 2520 Plunger pumps: 2530 thru 2831K, 3501 thru 3570, 3801HS thru 3841KHS
-------------	---



31013

32010

Float Valves

Maintains adequate liquid level in reservoir to provide consistent flow to pump inlet.

- Adjustable or preset models available.
- Compact and easy to install.

MODEL	MAXIMUM FLOW		MAXIMUM INLET PRESSURE		INLET PORT	INTERNAL BODY
	GPM	LPM	PSI	BAR		

ADJUSTABLE

31013	7.1	27	145	10	3/8" BSP(M)	Brass
-------	-----	----	-----	----	-------------	-------

PRESET

32010	8.0	30	145	10	3/4" BSP(M)	Polyethylene
-------	-----	----	-----	----	-------------	--------------

Specialty Accessories

Pressure Switches

Pressure-activated control device to control on-off operation of low amp system components.

- Non-adjustable, preset pressure setting for consistent system protection.
- 3-wire construction for either normally open or normally closed operation.

MODEL	MAXIMUM PRESSURE		SWITCHING PRESSURE		VOLTAGE RANGE	MAXIMUM AMP	INLET PORT
	PSI	BAR	PSI	BAR			

STAINLESS STEEL – NPT PORTS

31615	3650	250	215	15	12–250	6	¼" NPT(M)
31625	3650	250	360	25	12–250	6	¼" NPT(M)
31640	3650	250	580	40	12–250	6	¼" NPT(M)



31615

Flow Switches

Flow control device used to shut down pump when trigger on gun is released.

- Mount to discharge fitting of unloader to monitor when gun is open or closed.
- Use in conjunction with a relay switch.

MODEL	FLOW RANGE		MAXIMUM PRESSURE		MAXIMUM VOLTAGE	PORTS
	GPM	LPM	PSI	BAR		

BRASS MODELS

33786	1.6–15.9	6–60	5100	350	230	⅜" BSP(F)
33776	0.8–8	3–30	3650	250	250	⅜" BSP(M)
33778	1.0–15.9	3.8–60	5100	350	230	⅜" BSP(F)



33786

33776

Thermostat

Device to adjust and maintain temperature of a high-pressure water system.

- Adjustable to an accuracy of $\pm 5^\circ$ F.
- UL/CSA approved.

MODEL	TEMPERATURE RANGE	MAXIMUM PRESSURE		VOLTAGE RANGE	MAXIMUM AMPS	PORTS
		PSI	BAR			

76239	86°–302° F	4000	276	120–240	20	½" NPT(M) or ½" BSPP(M)
-------	------------	------	-----	---------	----	-------------------------



76239

Operator Controls

Guns, Gun & Lance Assemblies

Ergonomic construction with smooth trigger action-reducing operator fatigue.

- Safety lock to prevent unintentional operation.
- Stainless steel seat and ball for thousands of continuous cycles.



33425



76165



31137



39411



32300

MODEL	MAXIMUM FLOW		MAXIMUM PRESSURE		PORTS		STYLE	TRIGGER SQUEEZE
	GPM	LPM	PSI	BAR	INLET	DISCHARGE		

SHUT-OFF GUN, BRASS

33425	8	30	2900	200	3/8" NPT(F)	1/4" NPT(F)	Front load	Standard
76165	8	30	3650	252	3/8" NPT(F)	1/4" NPT(F)	Bottom Load	Standard
31260	8	30	5100	350	3/8" NPT(F)	1/4" NPT(F)	Bottom Load	Standard
35150	10.5	40	4500	310	3/8" NPT(F)	1/4" NPT(F)	Bottom Load	Standard
31137	10.5	40	4500	310	3/8" NPT(F)	1/4" NPT(F)	Horizontal	Standard
36140	10.5	40	5000	345	3/8" NPT(F)	1/4" NPT(F)	Bottom Load	Standard
31265	13	49	3650	252	3/8" NPT(F)	1/4" NPT(F)	Bottom Load	Standard
39410	21	80	7250	500	1/2" BSP(F)	1/2" BSP(F)	Bottom Load	Pressure Compensated
32183	31.7	120	4060	280	1/2" NPT(F)	1/2" NPT(F)	Horizontal	Standard
39415	32	121	1750	120	1/2" BSP(F)	1/2" BSP(F)	Bottom Load	Standard
39420	53	200	2900	200	3/4" BSP(F)	1/2" BSP(F)	Bottom Load	Pressure Compensated

SHUT-OFF GUN, STAINLESS

36126	10.5	40	4500	310	3/8" NPT(F)	1/4" NPT(F)	Bottom Load	Standard
33600	10.5	40	5800	400	3/8" NPT(F)	1/4" NPT(F)	Bottom Load	Standard
992641	10.5	40	14500	999	3/8" BSP(F)	3/8" BSP(F)	Bottom Load	Pressure Compensated

WEEP GUN, BRASS

76168	8	30	3650	252	3/8" NPT(F)	1/4" NPT(F)	Bottom Load	Standard
35151	10.5	40	4500	310	3/8" NPT(F)	1/4" NPT(F)	Bottom Load	Standard
36141	10.5	40	5000	345	3/8" NPT(F)	1/4" NPT(F)	Bottom Load	Standard

DUMP GUN, BRASS

32300 (15" Lance)	10	38	3000	207	3/8" NPT(F)	1/8" NPT(F)	Bottom Load	Standard
32301 (39" Lance)	10	38	3000	207	3/8" NPT(F)	1/8" NPT(F)	Bottom Load	Standard

MODEL	MAXIMUM FLOW		MAXIMUM PRESSURE		PORTS		LANCE LENGTH	TRIGGER SQUEEZE
	GPM	LPM	PSI	BAR	INLET	DISCHARGE		

SHUT-OFF GUN, BRASS, BOTTOM LOAD, WITH LANCE

39411	21	80	7250	500	1/2" BSP(F)	1/4" NPT(F)	16"	Pressure Compensated
39412	21	80	7250	500	1/2" BSP(F)	1/4" NPT(F)	32"	Pressure Compensated
39422	21	80	7250	500	1/2" BSP(F)	1/4" NPT(F)	50"	Pressure Compensated
39440	32	121	1750	120	1/2" BSP(F)	1/4" NPT(F)	32"	Standard

Operator Controls

Lances

A variety of lance types, lengths and materials ready to install to any ¼" gun.

- Ventilated insulator for operator comfort and safety.
- Durable nozzle protector reducing nozzle and property damage.

MODEL	MAXIMUM FLOW		MAXIMUM PRESSURE		LENGTH		PORTS	
	GPM	LPM	PSI	BAR	INCHES	MM	INLET	DISCHARGE

ZINC PLATED STRAIGHT TUBE WITH HAND GRIP

32264	10.5	40	3650	252	24	600	¼" BSP(M)	¼" BSP(M)
36267	10.5	40	3650	252	36	900	¼" BSP(M)	¼" BSP(M)
32268	10.5	40	3650	252	48	1200	¼" BSP(M)	¼" BSP(M)

ZINC PLATED TUBE WITH VENTED GRIP AND NOZZLE PROTECTOR

31017	10.5	40	3650	252	27	685	¼" BSP(M)	¼" NPT(F)
33201*	10.5	40	3650	252	35	890	¼" BSP(M)	¼" NPT(F)
32036	10.5	40	3650	252	36	900	¼" NPT(M)	¼" NPT(F)
32031	10.5	40	3650	252	36	900	¼" BSP(M)	¼" NPT(F)
32032	10.5	40	3650	252	48	1200	¼" BSP(M)	¼" NPT(F)

STAINLESS STEEL TUBE WITH VENTED GRIP AND NOZZLE PROTECTOR

31219	8	30	5100	350	32	812	¼" NPT(M)	¼" NPT(F)
31220	8	30	5100	350	42	1065	¼" NPT(M)	¼" NPT(F)
32042	10.5	40	3650	252	36	900	¼" NPT(M)	¼" NPT(F)
33200*	10.5	40	3650	252	43	1090	¼" BSP(M)	¼" NPT(F)

STAINLESS STEEL LANCE ASSEMBLY

32440**	32	121	1750	120	32	812	½" BSP(M)	¼" NPT(F)
32437	53	200	7250	500	16	406	½" BSP(M)	¼" NPT(F)
32438	53	200	7250	500	32	812	½" BSP(M)	¼" NPT(F)
39194	53	200	7250	500	50	1270	½" BSP(M)	¼" NPT(F)

* Dual Lance

** Steel Zinc Plated



32264

32036

Operator Controls



Nozzles

Applicator/orifice defines rate and pattern of fluid.

- Easily mounts to a ¼" lance.
- Nozzle types available: change over, rotating and turbo.
- Durable ceramic nozzle/insert for greater resistance to wear.

MODELS	MAXIMUM FLOW		MAXIMUM PRESSURE		PORT
	GPM	LPM	PSI	BAR	

CHANGE OVER NOZZLE WITH TWO ¼" NPT(F) NOZZLE HOLDERS

32149	7	26	2900	200	¼" BSP(F)
-------	---	----	------	-----	-----------

MODELS	NOZZLE SIZE	FLOW RANGE		PRESSURE RANGE		PORT
		GPM	LPM	PSI	BAR	

ROTATING NOZZLES 3000 PSI MAX

7265.20	2.0	1.1-1.7	4.1-6.4	1200-3000	83-207	¼" BSP(F)
7265.30	3.0	1.6-2.6	6.0-9.8	1200-3000	83-207	¼" BSP(F)
7265.35	3.5	1.9-3.0	7-11.4	1200-3000	83-207	¼" BSP(F)
7265.40	4.0	2.2-3.5	8.3-13	1200-3000	83-207	¼" BSP(F)
7265.45	4.5	2.4-3.9	9.1-14.8	1200-3000	83-207	¼" BSP(F)
7265.50	5.0	2.8-4.4	10.6-16.7	1200-3000	83-207	¼" BSP(F)
7265.55	5.5	3.0-4.8	11.1-18.2	1200-3000	83-207	¼" BSP(F)
7265.60	6.0	3.2-5.2	12.1-19.7	1200-3000	83-207	¼" BSP(F)
7265.65	6.5	3.6-5.7	13.6-21.6	1200-3000	83-207	¼" BSP(F)

ROTATING NOZZLES 3650 PSI MAX

7625.30	3.0	1.6-2.9	6.1-11	1200-3650	83-252	¼" BSP(F)
7625.35	3.5	1.9-3.3	7.2-12.5	1200-3650	83-252	¼" BSP(F)
7625.40	4.0	2.2-3.8	8.3-14.4	1200-3650	83-252	¼" BSP(F)
7625.45	4.5	2.4-4.3	9.1-16.3	1200-3650	83-252	¼" BSP(F)
7625.50	5.0	2.8-4.8	10.6-18.2	1200-3650	83-252	¼" BSP(F)
7625.55	5.5	3.0-5.2	11.4-19.7	1200-3650	83-252	¼" BSP(F)
7625.60	6.0	3.2-5.7	12.1-21.6	1200-3650	83-252	¼" BSP(F)
7625.65	6.5	3.6-6.2	13.6-23.5	1200-3650	83-252	¼" BSP(F)
7625.70	7.0	3.8-6.7	14.4-25.4	1200-3650	83-252	¼" BSP(F)
7625.80	8.0	4.4-7.7	16.7-29.1	1200-3650	83-252	¼" BSP(F)

ROTATING NOZZLES 5000 PSI MAX

7270.45	4.5	3.0-5.0	11.4-18.9	2000-5000	138-345	¼" BSP(F)
7270.55	5.5	3.8-6.2	14.4-23.5	2000-5000	138-345	¼" BSP(F)
7270.65	6.5	4.6-7.3	17.4-27.6	2000-5000	138-345	¼" BSP(F)
7270.80	8.0	5.6-8.9	21.2-33.7	2000-5000	138-345	¼" BSP(F)
7270.90	9.0	6.4-10	24.2-37.9	2000-5000	138-345	¼" BSP(F)

ROTATING NOZZLES 5100 PSI MAX

7632.30	3.0	2.4-3.4	9.1-12.9	2600-5100	180-350	¼" BSP(F)
7632.35	3.5	2.8-3.9	10.6-14.8	2600-5100	180-350	¼" BSP(F)
7632.40	4.0	3.2-4.5	12.1-17	2600-5100	180-350	¼" BSP(F)
7632.45	4.5	3.6-5.1	13.6-19.3	2600-5100	180-350	¼" BSP(F)
7632.50	5.0	4.0-5.6	15.1-21.2	2600-5100	180-350	¼" BSP(F)
7632.55	5.5	4.4-6.2	16.7-23.5	2600-5100	180-350	¼" BSP(F)
7632.60	6.0	4.8-6.7	18.2-25.4	2600-5100	180-350	¼" BSP(F)
7632.65	6.5	5.2-7.3	19.7-27.6	2600-5100	180-350	¼" BSP(F)
7632.70	7.0	5.6-7.9	21.2-29.9	2600-5100	180-350	¼" BSP(F)
7632.80	8.0	6.4-9.1	24.3-34.2	2600-5100	180-350	¼" BSP(F)

Need selection help?

If psi and nozzle gpm is known, then nozzle number can be calculated as follows:

$$\text{Nozzle number} = \text{gpm} \times \sqrt{\frac{4000}{\text{psi}}}$$

If psi and nozzle number is known, then gpm can be calculated as follows:

$$\text{gpm} = \text{nozzle number} \times \sqrt{\frac{\text{psi}}{4000}}$$

If gpm and nozzle number is known, then psi can be calculated as follows:

$$\text{psi} = \left(\frac{\text{gpm}}{\text{nozzle number}}\right)^2 \times 4000$$

A nozzle selection chart can also be found online at catpumps.com in the Literature section under Reference Documents.

Operator Controls

Vari-Nozzles

Used with downstream chemical injector to apply chemical at low pressure.

- Adjusts spray angle from 0° to 60° for cleaning flexibility.

MODELS	NOZZLE SIZE	FLOW RANGE		PRESSURE RANGE		PORT
		GPM	LPM	PSI	BAR	

VARI-NOZZLES

7920	2.0	1.0–1.9	3.8–7.2	100–3650	6.9–252	¼" BSP(F)
7930	3.0	1.5–2.9	5.7–10.8	100–3650	6.9–252	¼" BSP(F)
7935	3.5	1.8–3.3	6.6–12.6	100–3650	6.9–252	¼" BSP(F)
7940	4.0	2.0–3.8	7.8–14.4	100–3650	6.9–252	¼" BSP(F)
7945	4.5	2.2–4.3	8.3–16.3	100–3650	6.9–252	¼" BSP(F)
7950	5.0	2.5–4.7	9.5–17.8	100–3650	6.9–252	¼" BSP(F)
7955	5.5	2.8–5.2	10.6–19.7	100–3650	6.9–252	¼" BSP(F)
7960	6.0	3.0–5.6	11.4–21.2	100–3650	6.9–252	¼" BSP(F)
7970	7.0	3.5–6.6	13.2–25.0	100–3650	6.9–252	¼" BSP(F)



7920

Foamers

Draws chemical and air to create thick foam.

- Lance and chemical bottle can be fitted to a standard ¼" gun.
- Convenient chemical injector adjustment knob or handle for adjusting chemical draw.
- Stainless Steel orifice and FPM O-rings for chemical compatibility.

MODELS	FLOW RANGE		PRESSURE RANGE		TYPE	PORT
	GPM	LPM	PSI	BAR		

FOAMER, WITH AND WITHOUT BOTTLE

32017	2–4	7.6–15.2	750–2900	52–200	w/o Bottle	¼" BSP(F)
39234	2–4	7.6–15.2	750–2900	52–200	w/ 1-Liter Bottle	¼" BSP(F)
39196	2–4	7.6–15.2	750–2900	52–200	w/ 2-Liter Bottle	¼" BSP(F)



39196

32017

39234

Chemical Injectors

Provides and regulates chemicals into pump stream.

- Mount directly to unloader or in-line on discharge plumbing.
- Must be used with low-pressure nozzle to activate chemical draw.

MODEL	ORIFICE SIZE (MM)	FLOW RANGE		MAXIMUM PRESSURE		PORTS	
		GPM	LPM	PSI	BAR	INLET	DISCHARGE

BRASS – ADJUSTABLE

7182	1.8 mm	2–4	7.6–15	4050	279	¾" NPT(M)	¾" NPT(M)
7192	1.8 mm	2–4	7.6–15	4050	279	M18 x 1.0	¾" NPT(M)
7183	2.1 mm	3–5	11.4–19	4050	279	¾" NPT(M)	¾" NPT(M)
7193	2.1 mm	3–5	11.4–19	4050	279	M18 x 1.0	¾" NPT(M)
7184	2.3 mm	3–6	11.4–23	4050	279	¾" NPT(M)	¾" NPT(M)
7194	2.3 mm	3–6	11.4–23	4050	279	M18 x 1.0	¾" NPT(M)
7224	2.3 mm	3–6	11.4–23	4050	279	M22 x 1.5	¾" NPT(M)

BRASS – FIXED

7231	1.8 mm	2.0	7.6	3145	217	M18 x 1.0	¾" NPT(M)
7242	2.0 mm	2.9	12.9	2600	179	M18 x 1.0	¾" NPT(M)
7232	2.1 mm	3.0	11.4	3145	217	M18 x 1.0	¾" NPT(M)
7332	2.1 mm	3–4	11.4–15	3000	207	M18 x 1.0	¾" NPT(M)
7243	2.1 mm	3–5	11.4–19	4000	276	M22 x 1.5	¾" NPT(M)
7367	2.1 mm	3–5	11.4–19	4000	276	M20 x 1.0	¾" NPT(M)

STAINLESS STEEL – ADJUSTABLE

7722	1.8 mm	2–4	7.6–15	5100	352	¾" NPT(M)	¾" NPT(M)
7723	2.1 mm	3–5	11.4–19	5100	352	¾" NPT(M)	¾" NPT(M)
7724	2.3 mm	3–6	11.4–23	5100	352	¾" NPT(M)	¾" NPT(M)



7192

Operator Controls

Pulse Pumps

Harsh chemicals can damage the inner components of a high-pressure pump if run through the main pumping chamber. Pulse pumps from Cat Pumps are a cost-effective solution to bypass the primary pump, injecting these solutions down-stream and preventing premature wear on parts. This allows users to run standard high-pressure pumps instead of special, more costly stainless steel pumps with chemical-resistant seals.

The same proven quality and attention to detail that customers have come to expect from Cat Pumps is built into every pulse pump chemical injector. With pressures up to 207 bar (3,000 psi) and injection rates up to 12 gph, these pulse pumps can be used on a wide variety of new or existing systems. The installation process is so simple that pumps can be retrofitted quickly in the field.

Features

- Long lasting and simple to service
- Can be used with a wide range of high-pressure pumps, from small direct-drive to large belt-driven pumps
- Easy to retrofit in the field
- Accurate and easy-to-control injection rates
- Two pulse pumps can be used on one high-pressure pump to double chemical injection rate or use two separate chemicals
- Chemical pump can be turned on and off independently from main system

Typical Applications

- Sanitizing / Disinfecting
- Pressure Wash
- Truck Mount
- Vehicle and Equipment Wash
- Surface Cleaning



6340

6350

High-pressure injection downstream from the system pump.

- Eliminates harsh chemicals passing through pump.
- Simple field retrofit of existing pumps.

MODEL	FLOW RANGE		PRESSURE RANGE		PORTS	
	GPH	LPH	PSI	BAR	INLET	DISCHARGE

PULSE PUMPS FOR PLUNGER AND PISTON PUMPS

6340, 6341	1.0–10.5	3.8–40.0	100–2000	6.9–138	1/8" NPT(F)	1/8" NPT(F)
6350, 6351	1.0–12.0	3.8–45.4	500–3000	35–207	1/4" Hose Barb	1/8" NPT(F)

Note: Contact Cat Pumps for selection of Adapter Assembly to fit your pump model.

6340/6341 MAXIMUM INJECTION RATE

PUMP RPM	INJECTION RATE	PUMP RPM	INJECTION RATE
1000	5.5 gph	1500	10.0 gph
1100	7.0 gph	1600	10.5 gph
1200	8.0 gph	1700	10.5 gph
1300	9.0 gph	1800	10.5 gph
1400	9.5 gph		

6350/6351 MAXIMUM INJECTION RATE

PUMP RPM	INJECTION RATE	PUMP RPM	INJECTION RATE
500	5.0 gph	1000	10.0 gph
600	6.0 gph	1100	11.0 gph
700	7.0 gph	1200	12.0 gph
800	8.0 gph	1800	12.0 gph
900	9.0 gph		

INTERNAL DIAPHRAGM MATERIAL

6340	6341
EPDM	FPM

INTERNAL O-RING & VALVE MATERIAL

6350	6351
FPM O-Ring	FPM O-Ring
Acetal Inlet Valve	Stainless Steel Inlet Valve

Lubrication Accessories

Crankcase Oil

Genuine Cat Pumps crankcase oil provides maximum life and performance.

- Custom blend, premium grade, petroleum-based hydraulic oil for all Cat Pumps.
- Anti-wear additives protects metal-to-metal drive surfaces, extending drive life.
- High oxidative and chemical stability resists deposit formations and provides consistent fluid performance.
- Premium anti-corrosion additives offer protection in the most demanding operating environments.

PART NUMBER	CAPACITY	PUMP MODELS
OIL		
ISO 68		
Change after first 50 hours, then every 500 hours		
6107	Bottle – 21 ounces	All piston and plunger pumps
6100	Case – (12) 21 ounce bottles	
6102	Jug – 2.5 gallons	
6105	Twin pack – (2) 2.5 gallons	
6109	Drum – 30 gallons	
997657	Jug – 1 gallon	All piston and plunger pumps – Food Grade
997638	Case – (4) 1 gallons	
ISO 100		
Change after first 20 hours, then every 3000 hours		
6115	Pail – 5 gallons	152R060/C, 152R080/C, 152R100/C, 157R060/080, Specialty Pumps
6116	Drum – 16 gallons	
6121	Case – (4) 4 liters	

OILERS – GRAVITY FEED WITH ¼" NPT(M) THREADS

30278	1 ounce	2520/C, 2510/11, 2530–2537, Except 2831/K, 35/38 Series, Except 3541HS/3541KHS, 3545, 3841HS/3841KHS
30429	10 ounces	6020, 6040, 6760–6777, Except 6747 6861/K, Except 6801/K–6841/K



6107

Gear Lube

Maximize life with genuine Cat Pumps Gear Lube.

- Low friction and operating temperature for low wear, extending gear box life.
- Anti-wear, anti-rust, anti-corrosion formulation to extend gearbox life.
- Excellent oxidation and thermal stability extends fluid life.
- Used on all Cat Pumps gearbox pumps except 3CP1120G, 3CP1211G and 3CP1221G (crankcase oil is used instead of Gear Lube).

PART NUMBER	CAPACITY	PUMP MODELS
GEAR LUBE		
6110	Bottle – 16 ounces	45G1, 56G1, 56HSG1, 60G1, 700G1, 740G1, 760G1, 781G1, 5CP3105CSSG1, 5CP3120CSSG1, 5CP3160CSSG1, 5CP5135CSSG1, 5CP5140CSSG1, 5CP5140CSSG118, 5CP6120CSSG1, 5CP6180CSSG1, 5CP6190G1, 5CPQ6221G1, 5CPQ6241CSG1, 5CPQ6251G1, 7CP6165CSG1, 7CP6170G1, 7CP6110CSG1, 7CP6111CSG1, 5CP6190G1
6111	Case, (12) 16 ounce bottles	



6110

Lubrication Accessories

Anti-Seize and Sealants

Sealant and anti-seize ensure proper pump operation.

- Anti-Seize protects metal-to-metal surfaces from galling, seizing, friction and wear.
- Sealant is used to fill between mating surfaces within the manifold.



6124



6106



6139

PART NUMBER	CAPACITY	PUMP MODELS
-------------	----------	-------------

ANTI-SEIZE AND SEALANTS

6106	2 milliliters	Anti-Seize for pump shafts and keys – all plunger pumps
6139	8 ounces	Anti-Seize for threads – all stainless steel plunger pumps
6124	3 ounces	Liquid gasket for O-rings, seals – all plunger pumps

Loctite is a registered trademark of Henkel Corporation.

Pump Protector

The Ultimate Protection for Long-Term Storage of Pressure Washer Pumps.

The best solution: use specially formulated Pump Protector from Cat Pumps to protect your pressure washer pump from freezing, corrosion, mineral deposits and premature wear. Recommended for use with all pressure washers, Pump Protector adds lubrication to pistons, valves and seals to prevent sticking.



PART NUMBER	CAPACITY	PUMP MODELS
-------------	----------	-------------

PUMP PROTECTOR

6208	Case-(6) 12 oz bottles	All pressure washer pump models
------	------------------------	---------------------------------

How to Order: Order part number 6208 for a case of six bottles; 12 fluid ounces (355 ml) each

CHECK OUT

Cat Pumps Pressure Washer Pump Protector

Pressure washer pumps can be adversely affected during long-term storage, especially in cold temperatures. Cat Pumps specially formulates its Pump Protector to protect pressure washer pumps from freezing, corrosion and premature wear. Recommended for use with all pressure washers, Pump Protector adds lubrication to plungers, valves and seals to prevent sticking. There is no better way to protect a pump and safeguard your customers' investments.

www.catpumps.com/use-pump-protector-winter-storage



Pump Accessories

Oil Drain/Level Gauge Kits

Easily monitor crankcase oil level at-a-glance and improve pump maintenance.

- Conveniently monitor oil when existing bubble gauge is obscured.
- Oil drain kit can be mounted at desired location for easy maintenance.

MODEL	USED ON PUMP MODELS
OIL LEVEL GAUGE	
76144	Piston pumps: 2520 through 6041 Plunger pumps: 2510 thru 6861K. EXCEPT 35 and 38 Frame series
OIL LEVEL GAUGE W/DRAIN KIT	
76334	All Piston and Plunger pumps and 66DX, EXCEPT Plunger pumps 2SF, 2SFX, 4DX, 4DNX, 4SP, 4SPX and 5SP series
76074	All stainless steel or nickel aluminum bronze pumps, EXCEPT Plunger pumps 2SF, 2SFX, 4DX, 4DNX, 4SP, 4SPX, 5SP and 66DX series
DRAIN KITS	
34314	Piston pumps: 6020 thru 6041 Plunger pumps: 3501 thru 3570, 3801HS thru 3841KHS, 6747 thru 6775 and 6801 thru 6861K
34334	All piston and plunger pumps and 66DX, EXCEPT plunger pumps 2SF, 2SFX, 4DX, 4DNX, 4SP, 4SPX and 5SP series
990394	Plunger pumps: 2SF, 2SFX, 4DX, 4DNX, 4SP, 4SPX and 5SP series



76334

Protectors – Shaft and Oil Cap

Safety devices to eliminate exposure to rotating pump shaft and to minimize water leakage into pump.

- Shaft protector not included with pump unless otherwise noted.
- Oil cap protector not included with pump except 35/38 series pumps.

PART NUMBER	MATERIAL	PUMP MODELS
SHAFT PROTECTORS		
25130	STCP	230–277, 280, 290, 333, 430
26516	STCP	2520/C, 2510/11, 2530–2537, 2560, 2565, 2831/K
29445	AL	6020, 6040, 6747, 6760–6775, 6801/K, 6811/K, 6821/K, 6831/K, 6841/K, 6861/K, 67070, 67102 Included with pump
30764*	POP	650, 660, 1050, 1530, 1540E, 1560, 1570, 1580 (6 mm Holes)
307645*	POP**	661C, 661D, 1051, 1051C, 1051D, 1057, 1531, 1541, 1541C (6 mm Holes)
855046*	POP	650, 660, 1050, 1530, 1540E, 1560, 1570, 1580 Included with pump (8 mm Holes)
855047*	POP**	661C, 661D, 1051, 1051C, 1051D, 1057, 1531, 1541, 1541C Included with pump (8 mm Holes)
26516.15FR	STCP	1050.44101, 1051.44101, 1051C.44101, 1530.44101, 1531.44101, 1540E.44101, 1541.44101, 1541M.44101 Included with pump (8 mm Holes)
43139	STCP	621, 623, 820, 821, 1010, 1011
670066	STCP	530, 550
855042	POP	3501/C, 3507HS/CHS, 3511/C, 3517HS/CHS, 3520/C, 3521DHS/CHS, 3527HS, 3531DHS/CHS, 3535/C, 3537HS, 3541DHS/CHS, 3545, 3550, 3560, 3570, 3570S, 3801/K, 3811HS/KHS, 3821HS/KHS, 3831HS/KHS, 3841HS/KHS Included with pump
118672	STCP	310–350S, 311–357, 3CP1120–1140, 3CP1221–1241, 5CP2120W/2150W, 5CP3120, 5CP6120–6190, 5CPQ6221/6251
120220	STCP	7CP6170

* See Tech Bulletin 128 **Polypropylene protectors w/ two stainless screws.

OIL CAP PROTECTORS

Oil fill cap protector prevents water from entering crankcase. Not included with pump except on 4DX, 35 and 38 series pumps.

127409	PE	3CP, 5CP and 66DX Series
549726	PE	4DNX and 4DX Series
828710	PE	All piston and plunger pumps, EXCEPT the 1CX, 2SF, 2SFX, 3CP, 4DX, 4DNX, 4SP, 4SPX, 5CP, 5SP, 66DX, 67DX

Material codes: AL = Aluminum, NY = Nylon, PE = Polyethylene, STCP = Steel/Chrome Plated



29445

118672

828710

30764

Pump Accessories



Keys – Direct Drive

Provides alignment and secures pump shaft to motor shaft or hub/pulley.

- Keys supplied with Cat Pumps.
- Keys supplied with gearboxes and flexible couplings.

PART NUMBER	SIZE	PUMP MODELS
30050	3/16" x 3/16" x 1 1/4"	2SF Electric, Gas and Stainless Steel Series
30088	1/4" x 1/4" x 1 3/8"	Flexible Couplings: 8220, 8225, 8230
34050	3/16" x 3/16" x 27mm	4DNX25GSI/27GSI, 4DX Series, 4SP Series
44294	3/16" x 3/16" x 1 3/4"	Gearboxes (engine side): 8010, 8075
44459	8 x 7 x 24mm	Gearboxes (pump side): 8071, 8081
45217	1/4" x 1/4" x 64mm	66DX30G11/35G11/40G11/50G11
49411	1/4" x 1/4" x 59mm	67DX39G11
57352	5 x 5 x 21mm	Gearboxes (pump side): 8010, 8075
101814	6 x 6 x 27mm	Gearboxes (pump side): 8065, 8068, 8076, 8077
134760	1/4" x 1/4" x 45mm	5SP Series
831844	1/4" x 1/4" x 56mm	4SPX32G11

Keys – Belt Drive

Provides alignment and secures pump shaft to hub/pulley.

- Keys not supplied with pump.

PART NUMBER	SIZE (MM)	PUMP MODELS
30047	5 x 5 x 24	280, 290, 333, 430, 230–277, 3CP1120–1140, 1221–1241
30057	6 x 6 x 25 (round end)	323, 390, 45, 310–350S, 311–357, 5CP2120W–2150W, 5CP3120/3120CSS, 5CP5120–5140CSS, 5CP6120–6190, 5CPQ6221–6251 and Clutch models: 34962/63, 34970/80
30067	8 x 7.25 x 25	56, 530, 550, 700, 740, 760, 781/K, 784, 786, 650–661D, 1050–1057, 1530/31, 1540E/41, 1810/K, 7CP6110CS–7CP6185CS
30089	5 x 5 x 36.5	Clutch models: 34960/961, 34964/965
34021	10 x 8 x 70	3501/C, 3507HS/CHS, 3511/C, 3517HS/CHS, 3520/C, 3521DHS/CHS, 3527HS, 3531DHS/CHS, 3535/C, 3537HS, 3541DHS/CHS, 3545, 3550, 3560, 3570, 3570S 3801–3841K
35034	6 x 8 x 26 (Step)	Clutch model: 34299
43048	14 x 9 x 90	6020, 6040, 6747, 6760–6775, 6801–6861K, 67070, 67102/C
50146	7 x 7 x 40	621, 623, 820, 821, 1010, 1011, 1951
890601	28 x 170 (Step)	152R060/C, 152R080/C, 152R100/C, 157R060, 157R080
890602	28 x 16 x 170	152R060/C, 152R080/C, 152R100/C, 157R060, 157R080
990036	8 x 7 x 40	1530/31, 1540E/41, 1560, 1570, 1580, 2510/11, 2520/C, 2530–2537, 2560, 2565, 2831/K
990069	8 x 6.35 x 40	Clutch model: 34563
991036	8 x 7 x 36	Clutch models: 34628, 34630

Pump Accessories

Rail, Direct Mount and Complete Mounting Assemblies

Mount pump onto a secure, horizontal base with either rail assemblies or direct-mount assemblies.

- Rail assembly, direct mount assembly or complete mounting assembly not included with pump unless otherwise noted.
- Use direct mount assembly when mounting block or flat base is used or pulley extends over edge of base.

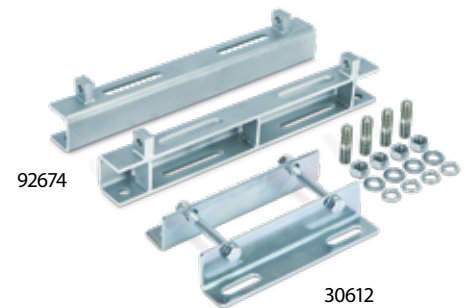

PART NUMBER	PUMP MODELS
-------------	-------------

RAIL ASSEMBLIES – STEEL/ZINC PLATED/STAINLESS STEEL

126604	6020, 6040, 6747, 6760–6775, 6801/K, 6811/K, 6821/K, 6831/K, 6841/K, 6861/K Included with pump
30611	333, 430, 323, 390, 310–350S, 311–357, 530, 550, 700, 740, 760, 781/K, 784, 786, 31, 45, 60, 5CP2120W–2150W, 5CP3120/3120CSS, 5CP5120–5140CSS, 5CP6120–6190, 5CPQ6221–6251
30612	280, 290, 230–277, 3CP1120–1140, 3CP1221–1241, 3CP1211CS
30613	623–1010, 650–661D, 1050–1057, 1530/31, 1540E/41, 1560, 1570, 1580, 1810/K, 7CP6110CS–6185CS
30614	2520/2520C, 2510/11, 2530–2537, 2560, 2565, 2831/K
30637	5CP2120W–2150W, 5CP3120/3120CSS, 5CP5120–5140CSS, 5CP6120–6190, 5CPQ6221–6251 (Retrofit to GP/IP**)
30645	530, 550, 45, 56, 60, 700, 740, 760, 781/K, 784, 786
76513	310–350S, 311–357, 530, 550, 56, 60, 5CP2120W–2150W, 5CP3120/3120CSS, 5CP5120–5140CSS, 5CP6120–6190, 5CPQ6221–6251
92674	3501/C, 3507HS/CHS, 3511/C, 3517HS/CHS, 3520/C, 3521DHS/CHS, 3527HS, 3531DHS/CHS, 3535/C, 3537HS, 3541DKHS, 3520, 3545, 3550, 3560, 3570, 3570S, 3801/K, 3811HS/KHS, 3821HS/KHS, 3831HS/KHS, 3841HS/KHS
76514	3501/C, 3507HS/CHS, 3511/C, 3517HS/CHS, 3520/C, 3521DHS/CHS, 3527HS, 3531DHS/CHS, 3535/C, 3537HS, 3541DKHS, 3520, 3545, 3550, 3560, 3570, 3570S, 3801/K, 3811HS/KHS, 3821HS/KHS, 3831HS/KHS, 3841HS/KHS 304 Stainless Steel
990550	650, 660–661D, 1050, 1051, 1057, 1530, 1531, 1540E, 1541, 1560, 1570, 1580, 1730, 1810/K For Diesel or Gas Mounts

DIRECT MOUNT ASSEMBLIES – STEEL/ZINC PLATED

30243	333, 430, 323, 390, 310–350S, 311–357, 530, 550, 700, 740, 760, 781/K, 784, 786, 45, 56, 60, 5CP2120W–2150W, 5CP3120/3120CSS, 5CP5120–5140CSS, 5CP6120–6190, 5CPQ6221–6251
30264	623–1010, 650–661D, 1050–1057, 1530/31, 1540E/41, 1560, 1570, 1580, 1810/K, 7CP6110CS–6185CS
34018	3520/C, 3535, 3545, 3560
34039*	3501/C, 3507HS/CHS, 3511/C, 3517HS/CHS, 3521DHS/CHS, 3527HS, 3531DHS/CHS, 3537HS, 3541DHS/CHS, 3801/K, 3811HS/KHS, 3821HS/KHS, 3831HS/KHS, 3841HS/KHS

MOUNTING ASSEMBLIES (INCLUDES: RAILS, KEY, PULLEY/HUB AND SHAFT PROTECTOR)

30641	3CP1120–1140, 3CP1221–1241
30651	280, 290, 230–277
30652	333, 430
30653	623–1010
30659	323, 390, 310–350S, 311–357, 5CP2120W–5CP2150W, 5CP3120/CSS, 5CP5120–5CP5140CSS, 5CP6120–5CP6190, 5CPQ6221–6251
30660	530, 550, 700, 740, 760, 781/K, 784, 786, 56, 60
30661	650–661D, 1050–1057, 1530/31, 1540E/41, 1560, 1810/K

* 304 stainless steel ** See Tech Bulletin 078

NEMA Mounting Components

Bell Housing and Flexible Coupling

Compact direct mounting to hydraulic or electric motors reducing space requirements.

- Coupling assembly includes metric and standard coupling halves, spyder and keys.
- Special urethane flexible spyder designed for extended life with high temperature and high rpm.
- Used with standard NEMA electric motors.



56HS with NEMA Bell Housing and Motor

NEMA Bell Housing Assemblies

PUMP SERIES	MODELS	MOTOR FRAME	BELL HOUSING ASSY
3CP	All 3CP Models	56C-145TC	76056.3CP
		182/184TC	76184.3CP
		213/215TC	76215.3CP
3FR	230, 231, 237, 240, 241, 247, 270, 271, 277	56C-145TC	76056.3FR
		182/184TC	76184.3FR
		213/215TC	76215.3FR
		56C-145TC	76056.5CP
5CP	All 5CP Models (Except 5CP2120W)	182/184TC	76184.5CP
		213/215TC	76215.5CP
		254/256TC	76256.5CP
		56C-145TC	76056.5FR
5FR	340, 341, 347, 350, 351, 357	182/184TC	76184.5FR
		213/215TC	76215.5FR
		182/184TC	76184.7CP
		213/215TC	76215.7CP
7CP	All 7CP Models	254/256TC	76256.7CP
		182/184TC	76184.7FR
		213/215TC	76215.7FR
7FR/8FR	56, 56HS, 60, 700, 740, 760, 781, 784, 786	254/256TC	76256.7FR
		213/215TC	76215.15FR
		254/256TC	76256.15FR
		284/286TC	76286.15FR
15 FR/18FR *	All 15 & 18FR models		

* See page 47 for 1180 rpm motor options for some 15FR pumps.



NEMA Flexible Coupler Assemblies

PUMP SERIES	MOTOR FRAME	FLEX COUPLER ASSY	SHAFT TO SHAFT	TORQUE RATING FT-LB
3CP & 3FR	56C	8215	16.5mm x 5/8"	27
	145TC	8210	16.5mm x 7/8"	27
	182/184TC	8220	16.5mm x 1 1/8"	27
5CP & 5FR	182/184TC	8225	16.5mm x 1 1/8"	74
	213/215TC	8270	16.5mm x 1 3/8"	92
	56C	8261	20mm x 5/8"	74
	145TC	8260	20mm x 7/8"	74
7CP & 7FR	182/184TC	8230	20mm x 1 1/8"	74
	213/215TC	8275	20mm x 1 3/8"	92
	245/256TC	8217	20mm x 1 5/8"	92
	56C/145TC	8218	24mm x 5/8"	74
15FR & 18FR	182/184TC	8370	24mm x 1 1/8"	74
	213/215TC	8375	24mm x 1 3/8"	74
	254/256TC	8380	24mm x 1 5/8"	92
	284/286TC	8389	24mm x 1 7/8"	150
15FR & 18FR	213/215TC	8388	30mm x 1 3/8"	150
	254/256TC	8382	30mm x 1 5/8"	150
	284/286TC	8383	30mm x 1 7/8"	225



Need selection help?

Q. How can I find the rpm needed to get specific gpm I want?

A. $\text{Desired rpm} = \frac{\text{Desired gpm} \times \text{Rated rpm}}{\text{Rated gpm}}$

Q. I have to run my pump at a certain rpm. How do I figure the gpm I'll get?

A. $\text{Desired gpm} = \frac{\text{Desired rpm} \times \text{Rated gpm}}{\text{Rated rpm}}$

Q. Is there a simple way to find the approximate horsepower I'll need to run the pump?

A. Electric Brake Horsepower (Standard 85% Mech. Efficiency)

$$\text{Required hp}^* = \frac{\text{gpm} \times \text{psi}}{1460}$$

Q. What size motor pulley should I use?

A. $\text{Pump Pulley (Outer Diameter)} \times \frac{\text{Pump rpm}}{\text{Motor/Engine rpm}}$

*Consult Engine Manufacturer

Motor Options

"C" Face, 60 Hz

Provides easily-assembled pump and motor units.

- Motors from Marathon Electric, WorldWide Electric and WEG.
- Contact Cat Pumps for additional motor options, like IEC, 50 Hz, RPM options, EXP and more.

HORSE POWER	VOLTAGE	FRAME	PART NUMBER
-------------	---------	-------	-------------

1 PH, 1750 RPM, TEFC

0.5	115/*230	56C	8105
0.75	115/*230	56C	8175
1	115/*230	56C	8110
1.5	115/*230	56C	8115
2	115/*230	56C	8120
2.5	115/*230	56C	8125
3	*230/460	184TC	999839
5	*230/460	184TC	997634
7.5	*230/460	215TC	999766
10	*230/460	215TC	999720

1 PH, 3450 RPM, TEFC OR ODP

1.5	115/230	56C	8054 ¹
2	115/230	56C	999943
3	115/*230	56C	992139 ²
5	230	56C	80573 ³

¹ TEFC with 5/8" Shaft

² ODP with 5/8" Shaft

³ ODP with 3/4" Shaft

3 PH, 1180 RPM, TEFC

5	*230/460	215TC	994274
7.5	*230/460	256TC	994975
10	*230/460	256TC	994910
15	*230/460	286TC	994915
20	*230/460	286TC	994920

3 PH, 1750 RPM, TEFC

0.33	200-230/460	56C	990324
0.5	*230/460	56C	997671
1	*230/460	56C	999189
1.5	*230/460	56C	998843
2	*230/460	56C	899247
2.5	208-230/460	56C	8126
3	*230/460	182TC	899302
5	*230/460	184TC	996543
7.5	*230/460	213TC	999436
10	*230/460	215TC	999377
15	*230/460	254TC	994001
20	*230/460	256TC	997645

3 PH, 3450 RPM, TEFC

1.5	*230/460	56C	994794
3	230/460	56C	8053

* Prior to Department of Energy (DOE) EERE-2020-BT-TP-0011, motor was name plated 208-230 Volts.

Drive Flexibility

Motors can be sold separately or with a pump as an assembled unit.



Motor-Driven Applications

- Pressure Washers
- Industrial High-Pressure Power Units
- Self-Serve Car Wash
- Car Wash Prep Units
- Washdown Systems
- Misting/Cooling/Fogging System
- Salt Water Desalination/SWRO



SAE Mounting Components

SAE Bell Housing Assemblies

PUMP SERIES	MODELS	SAE TYPE	BELL HOUSING ASSEMBLY
3CP	All 3CP Models	A2	76SAEA2.3CP
		B2	76SAEB2.3CP
		B4	76SAEB4.3CP
3FR	All 3-Frame Models	A2	76SAEA2.3FR
		B2	76SAEB2.3FR
		B4	76SAEB4.3FR
5CP	All 5CP Models	A2	76SAEA2.5CP
		B2	76SAEB2.5CP
		B4	76SAEB4.5CP
5FR	All 5-Frame Models	A2	76SAEA2.5FR
		B2	76SAEB2.5FR
		B4	76SAEB4.5FR
7CP	All 7CP Models	A2	76SAEA2.7CP
		B2	76SAEB2.7CP
		B4	76SAEB4.7CP
7FR	All 7-Frame Models	A2	76SAEA2.7FR
		B2	76SAEB2.7FR
		B4	76SAEB4.7FR
15FR	All 15-Frame Models	B2	76SAEB2.15FR
		B4	76SAEB4.15FR
25FR	All 25-Frame Pumps	C2/C4	76SAEC.25FR
35FR	All 35-Frame Pumps	C2/C4	76SAEC.35FR



5CP3120CSS with SAE Bell Housing and Motor

SAE Flexible Coupler Assemblies

PUMP SERIES	SAE TYPE	FLEX COUPLER ASSY	SHAFT TO SHAFT	TORQUE RATING FT·LB
3CP & 3FR	A2	8271	16.5mm x 5/8"	74
	B2/B4	8272	16.5mm x 7/8"	74
5CP & 5FR	A2	8273	20mm x 5/8"	74
	B2/B4	8274	20mm x 7/8"	74
7CP & 7FR	A2	8371	24mm x 5/8"	92
	B2/B4	8372	24mm x 7/8"	92
15FR	B2/B4	8387	30mm x 7/8"	150
25FR	B2/C4	994303	30mm x 1 1/4"	188
	C2/C4	997872	35mm x 1 1/4"	350
35FR	C2/C4	999368	35mm x 1 3/8"	350
	C2/C4	994403	35mm x 1 1/2"	350
	C2/C4	999180	35mm x 1 5/8"	350
	C2/C4	999206	35mm x 1 7/8"	350

Bell Housing Assemblies include mounting hardware and flange

SAE TYPE:

- A2 = SAE "A" 2 Bolt, 3.25" Pilot
- B2 = SAE "B" 2 Bolt, 4" Pilot
- B4 = SAE "B" 4 Bolt, 4" Pilot
- C2 = SAE "C" 2 Bolt, 5" Pilot
- C4 = SAE "C" 4 Bolt, 5" Pilot



76SAEB4.7CP



8274

Drive Accessories

Hubs and Hub/Key Assemblies

Metric sized hubs to match metric shaft diameter of pump.

- Contact Cat Pumps for available hubs for motor shafts.
- Metric sized hub with matching metric key for pump shaft only.

DIAMETER (MM)	TYPE	PART NUMBER	PUMP MODELS
HUB (STEEL)			
16.5	H	30943 *	All 3-Frame, 3CP and 4-Frame Models
20	H	30945 *	All 5-Frame, 5CP Models
24	H	33000 *	All 7-Frame, 7CP and 8-Frame Models
25	H	30234	All 10-Frame Models
30	B	990012 *	All 15-Frame, 18-Frame, 25-Frame and 28-Frame Models
30	H	30059 *	
35	B	990013 *	All 35-Frame and 38-Frame Models
45	B	990014 *	All 60-Frame and 68-Frame Models
100	M	990068	All 150R-Frame Models

Note: *Add "Z" to part number for zinc plated hub

HUB AND KEY ASSEMBLY (STEEL)

16.5	H	30942	All 3-Frame, 3CP and 4-Frame Models
20	H	30944	All 5-Frame, 5CP Models
25	H	30284	All 10-Frame Models
30	H	30209	All 25-Frame and 28-Frame Models



990013

Clutches

Engages/disengages pump and drive device to meet flow demands.

- Reduces amount of time pump is running, saving energy and increasing pump life.
- Broad range of clutches up to 100 ft-lb torque for high performance.

MODELS	CLUTCH DIAMETER/ NUMBER OF GROOVES	BELT TYPE	PUMP SHAFT DIAMETER	PUMP MODELS
34960	7" / 1	A	16.5 mm	All 3CP Models
34961	7" / 1	A	16.5 mm	All 3-Frame and 4-Frame Models
34962	7" / 1	A	20.0 mm	All 5-Frame Models
34963	7" / 2	A	20.0 mm	All 5-Frame Models
34964	7" / 2	A	16.5 mm	All 3-Frame and 4-Frame Models
34965	7" / 2	A	16.5 mm	All 3CP Models
34970	7" / 1	A	20.0 mm	All 5CP Models
34980	7" / 2	A	20.0 mm	
34971	7.3" / 8	Poly-V, L-Style	24.0 mm	All 7CP Models
76970	10" / 2	B	20.0 mm	All 5CP Models
76980	10" / 2	B	20.0 mm	All 5-Frame Models
34628	12.4" / 1	B	24.0 mm	All 7-Frame and 8-Frame Models
34630	12.4" / 2	B	24.0 mm	All 7-Frame and 8-Frame Models
34563	12.4" / 2	B	30.0 mm	All 15-Frame and 18-Frame Models
30655	12.4" / 2	B	30.0 mm	All 25-Frame and 28-Frame Models

Note: Do not exceed 100 ft-lb for models 2560, 2565



34965

Drive Accessories



30206

Pulleys and Pulley/Hub w/Key

A combination one-piece pulley and hub construction for pump shaft installation.

- Contact Cat Pumps for available pulley sizes for either pump or motor side.

PUMP SHAFT DIAMETER (MM)	PART NUMBER	PULLEY DIAMETER NO. OF GROOVES	BELT TYPE	PUMP MODELS
--------------------------	-------------	--------------------------------	-----------	-------------

PULLEY/HUB COMBINATION WITH TWO SET SCREWS (STEEL/ZINC PLATED)

16.5	30032	5" / 1	A	All 3-Frame, 3CP and 4-Frame Models
16.5	30048	8" / 1	A/B	All 3-Frame, 3CP and 4-Frame Models
20	30058	8" / 1	A/B	All 5-Frame and 5CP Models

PULLEY/HUB COMBINATION WITH TWO SET SCREWS AND KEY ASSEMBLY (STEEL)

16.5	30244	8" / 1	A/B	All 3-Frame, 3CP and 4-Frame Models
16.5	30246	5" / 1	A	All 3-Frame, 3CP and 4-Frame Models
20	30633	8" / 1	A/B	All 5-Frame and 5CP Models

PULLEY ONLY (CAST IRON)

HUB SIZE	PART NUMBER	PULLEY DIAMETER NO. OF GROOVES	BELT TYPE	PUMP MODELS
H	30206	10" / 2	A/B	All 7-Frame, 8-Frame, 15-Frame, 18-Frame, 25-Frame and 28-Frame Models

Service Tools



30696

33285

Pliers

Quick valve and snap ring removal/installation.

- Reverse pliers used for easy valve seat removal.
- Snap ring pliers used for Inlet Stabilizers assemblies.

REVERSE PLIERS

MODEL	30696
-------	-------

SNAP RING

MODEL	33285
-------	-------



44050

Oil Gauge Removal Tool

Quick and easy replacement of crankcase oil gauge.

- Required for replacement of oil gauge.

MODEL	44050
SIZE	M28

Service Tools

Seal Case Removal Tools

Simplifies seal replacement for various plunger pumps.

- Available as ½" drive socket or T-wrench.

½" DRIVE SOCKETS

MODEL	33004	33005*	33006
FRAME	5 Frame	7 Frame	15 Frame

T-WRENCHES

MODEL	45103	43257	43523
FRAME	5 Frame	7 Frame	15 Frame

* For model 45, use 7 frame seal case removal tool.



Piston Pump Tools

These specialty installation tools minimize risk of damage to cup/seal during replacement.

- Used for piston pumps only.

CUP INSTALLATION

MODEL	16981	22130	43548	43749	27964	15770	27853
MODELS USED	280, 290, 820	280, 290, 820	320, 323	333	390	1010	2520

SEAL INSTALLATION

MODEL	25084
FRAME	3, 4 Frame



Crankcase Oil Seal Kits for 35 Frame and 60 Frame

This specialty oil seal tool kit will assist in replacement of the 35 and 60 frame crankcase oil seals.

- Remove and re-install crankcase oil seal from crankcase.
- Minimize risk of damage to plunger/piston rod surfaces.
- Used for plunger or piston pumps.

FOR 35 FRAME PUMPS

MODEL	32273
INCLUDES	3 Oil Seals, Guide Tool, Screws, Washers, #2 Phillips Driver

FOR 60 FRAME PUMPS

MODEL	31173
INCLUDES	3 Oil Seals, Guide Tool, Screws, Washer

MODEL	32357 (Used on Pump Models 67070, 67102, 67102C)
INCLUDES	3 Oil Seals, Guide Tool, Screws, Washer



CHECK OUT

35 Frame Oil Seal Replacement Tool Step-by-Step Video



New Products and Updates

Cat Pumps continues to build on its market leading position with the introduction of new products. Every new product is built with the same winning business philosophy: manufacture the longest-lasting most dependable products and back them with availability from stock. Contact us to learn why customers worldwide trust Cat Pumps to keep their equipment running.

MODEL 1731 STAINLESS STEEL DIRECT-DRIVE PLUNGER PUMP

1731

The Model 1731 direct-driven stainless steel triplex pump is capable of achieving an unequaled 15.8 gpm at 1,500 psi. With a bell housing, the Model 1731 easily attaches to a "C" face motor (1750 rpm), allowing for a space-saving footprint.

Max Flow:	15.8 gpm / 60 lpm	
Max Pressure:	1500 psi / 103 bar	
Max RPM:	1750	• Salt and Brackish Water Desalination (SWRO)
Inlet Ports (2):	1" NPT(F)	• Leachate Treatment
Discharge Ports (2):	¾" NPT(F)	• Gas Turbine Cooling



NEW 7CP SERIES PUMP MODELS FOR 8 GPM AT 3,500 PSI

7CP6185CS (BELT-DRIVE); 7CP6165CSG1/7CP6165CSG118 (DIRECT-DRIVE)

Expansion and refinement of our existing 7CP series pumps have led to the development of three new pump models capable of 8 gpm at 3,500 psi to meet demanding mobile trailer pressure washing needs. Model 7CP6185CS is belt-driven, while the Model 7CP6165CSG1 pairs to an engine with a 1" horizontal shaft, and Model 7CP6165CSG118 mates with a 1 ½" shaft.

Max Flow:	8 gpm / 30.3 lpm	
Max Pressure:	3500 psi / 241 bar	
Max RPM (Belt-Drive):	1320	• Mobile Pressure Wash
Max RPM (Direct-Drive)	3265	• Water Jetting
Inlet Ports (2):	¾" NPT(F)	• Hydro Excavating
Discharge Ports (2):	½" NPT(F)	



5CP4100CSS SERIES MODULAR UNLOADERS

7865/7866/7867

By building on the simplicity and strength of our existing modular unloaders, Cat Pumps engineers have created an unloader design to match up with our 5CP4100CSS Series Pumps, and meet the demands of our customer's high-pressure application needs. Model 7865 features a 2.1 mm orifice chemical injector, and Model 7866 has a 1.8 mm orifice. For applications where an injector is not required, model 7867 includes a standard discharge fitting.

Flow Range:	0.5–6.0 gpm / 1.9–23 lpm
Pressure Range:	100–4000 psi / 6.9–276 bar
Maximum Temperature:	160° F / 71° C
Inlet Port (1):	½" NPT(F)
Outlet Port (1):	¾" NPT (M)
Bypass Port:	Built-In Channel
Dimensions:	4.12 x 1.75 x 7.00" / 105 x 44 x 178 mm



New Informational Videos



Pop-off valves provide backup protection as a secondary pressure relief valve to ensure complete pressure relief for maximum pump and system protection. See our pop-off valve Troubleshooting Tips video for useful information on why and when to use pop-off valves and how to set pressure properly.

www.catpumps.com/troubleshooting-tips-pop-off-valves



The typical method of replacing crankcase oil seals is complicated and involves removing the two bearing covers, the crankshaft and bearings, and the plunger rod and connecting rod assemblies before finally removing the oil seals. This can be incredibly time-consuming. Check out the new replacement tool that allows replacement of 35-frame oil seals in a fraction of the time with much less effort.

www.catpumps.com/oil-seal-replacement-tool-kit-and-service-video-35-frame-pumps



Watch the latest 1540E maintenance videos for step-by-step instructions on proper pump disassembly and reassembly, as well as the periodic inspection and replacement of valves and seals.

www.catpumps.com/new-service-videos-1540-series



TECH TIP

www.youtube.com/watch?v=eL09-JanVoY



Pump Rotation: Forward rotation is recommended to allow optimum lubrication of the drive end.

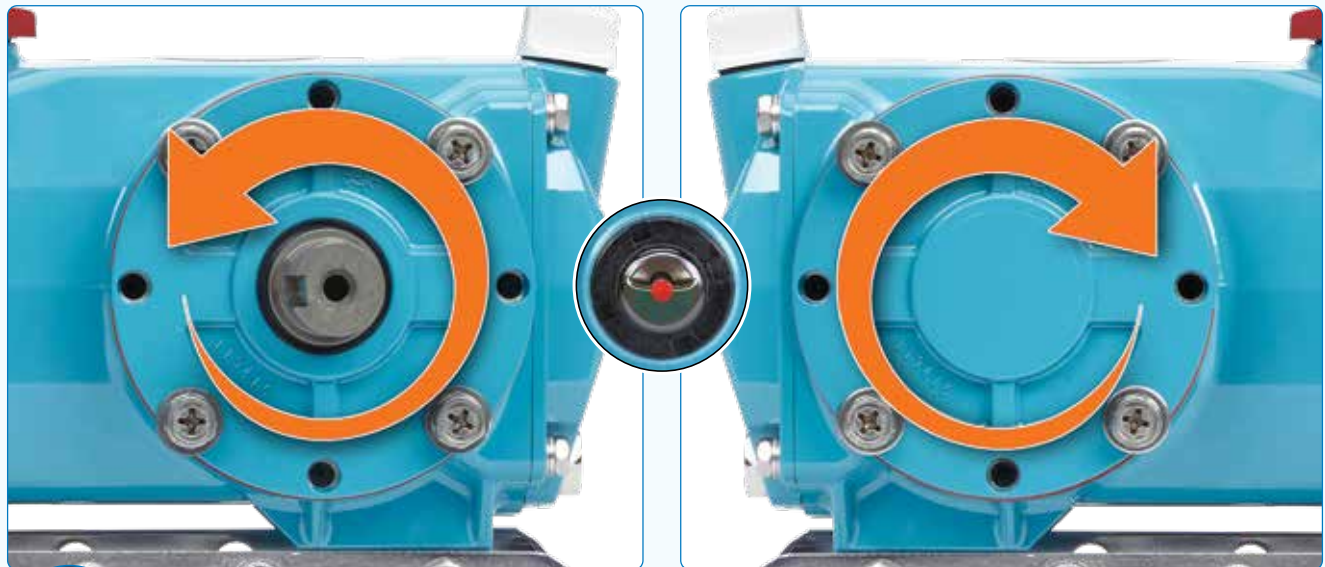

Note: If your installation does not allow forward rotation, reverse rotation is acceptable if the crankcase oil level is filled slightly above the red dot in the oil gauge, ensuring adequate lubrication.

Cat Pumps Resources On-Demand

Take advantage of the many support options Cat Pumps offers its distributors, OEMs and end users. From live service and support to 24/7 online information and materials, customers can get help they need, when they need it.



✓ All-New catpumps.com

Answers to your questions can be just a click away. Get up-to-date product information, service documents and videos, pump and system configuration tools, and more!

- A blog to keep you updated on the latest Cat Pumps news and developments
- A new mobile-friendly platform, ensuring the best experience on any device
- Upgraded worldwide distributor search engine offers faster, more customizable results



✓ Product, Application & Service Literature

Complete catalogs of pumps, accessories and systems are available in print and online on our website. Sales literature includes the following items:

- Sell Sheets and brochures for specific markets and products
- Design guides for high-pressure systems and flush-style pumps
- Technical Bulletins



✓ Training Videos

Informative “Whiteboard Sessions” videos cover a variety of technical topics in short and easy-to-comprehend lessons conducted by Cat Pumps engineering.

Find them at www.catpumps.com/whiteboard-sessions and on the Cat Pumps YouTube channel.



✓ Service Videos

Learn how to service seal and valve kits in these authorized Cat Pumps videos, hosted on the Cat Pumps YouTube channel and website.

Find them at these links:

www.catpumps.com/service-videos

www.youtube.com/catpumps1968



✓ Live Industry-Leading Service & Support

Cat Pumps knowledgeable and experienced customer service team provides assistance with order information, as well as technical support in product selection, installation, maintenance, pump repair and general system troubleshooting.

Live Support is available M–F, 8:00 a.m. to 5:00 p.m. CST at (763) 780-5440.

Customer Care: orders@catpumps.com | Tech Support: techsupport@catpumps.com

Customer Service — Another Cat Pumps Difference



When customers do business with Cat Pumps, they benefit not only from long-lasting dependable products, but also from excellent customer service and support. Cat Pumps customers enjoy the following benefits:

- 98.68% order fill rate, supported by world-class inventory management system
- 99.98% shipping accuracy, which means customers receive what they ordered
- Worldwide distribution network stocking genuine Cat Pumps products and parts
- Industry-leading customer service with “live” support, from phone operators to Technical Services
- Experienced staff on call to assist with inquiries, from designing power units to system troubleshooting
- “Account Access” on-line portal provides 24/7 access to registered customers to enter purchase orders, receive up-to-date pricing, and track orders. Contact Cat Pumps for more information.
- Email sales@catpumps.com for fast response to questions and requests or call (763) 780-5440

Sales and service support is provided by highly qualified distribution network covering the U.S., Canada, and Mexico. Cat Pumps has an international presence with sales offices in the U.K., Belgium and Germany, as well as a worldwide distribution channel.

Complete, Accurate and Fast Order Shipping



Pumps and parts are stocked for off-the-shelf delivery. Wherever customers are in the world, Cat Pumps service and support are never far away. Long-lasting products backed by excellent customer service are why Cat Pumps is the best choice for high-pressure pumps and systems.



Cat Pumps occupies over 145,000 square feet at its world headquarters in Minneapolis, MN.

Cat Pumps Locations

Cat Pumps–World Headquarters

1681 94th Lane Northeast
Minneapolis, MN 55449
USA
P: (763) 780-5440
F: (763) 780-2958
techsupport@catpumps.com
www.catpumps.com

Territories Served
United States, Canada

International Division

P: (763) 780-5440
F: (763) 785-4329
intlsales@catpumps.com
www.catpumps.com

Territories Served
Africa, Asia, Australia, Central and South America, Mexico, Middle East, New Zealand, Turkey

Cat Pumps International N.V.

Heiveldekens 6A
2550 Kontich
Belgium
P: 32 3 450 71 50
F: 32 3 450 71 51
cpi@catpumps.be
www.catpumps.be

Territories Served
Western Europe (except U.K., Germany, and Austria)

Cat Pumps (U.K.) Ltd.

1 Fleet Business Park, Sandy Lane
Church Crookham
FLEET, Hampshire GU52 8BF
England
P: +44 (0) 1252 622031
F: +44 (0) 1252 626655
sales@catpumps.co.uk
technical@catpumps.co.uk
www.catpumps.co.uk

Territories Served
United Kingdom and Ireland

Cat Pumps Deutschland GmbH

Buchwiese 2, D-65510
Idstein
Germany
P: +49 6126 9303 0
F: +49 6126 9303 33
info@catpumps.de
www.catpumps.de

Territories Served
Austria, Commonwealth of Independent States (CIS), Germany and Eastern Europe

SALES, DISTRIBUTION, SERVICE Call today for product and application assistance. (763) 780-5440 or visit us at www.catpumps.com



CAT PUMPS

1681 - 94TH LANE N.E. MINNEAPOLIS, MN 55449-4324
PHONE (763) 780-5440 — FAX (763) 780-2958
e-mail: info@catpumps.com
www.catpumps.com

For International inquiries go to www.catpumps.com and navigate to the “Contact Us” link.

©2020–2024 Cat Pumps Inc. All rights reserved. All written and visual data contained in this document are based on the latest product information available at the time of publication. Cat Pumps reserves the right to make changes at any time without notice. All other brand names or marks are used for identification purposes and are trademarks of their respective owners.

©2021–2024 Cat Pumps. All Rights Reserved. PN 99CAT001 Rev C 24025 9/24