

# SERVICE BULLETIN 004



## 35 Frame Crankcase Oil Seal Replacement Tool Kit

Use Seal Tool Kit PN 32273 to remove plunger rod oil seals if oil leaks between the inlet manifold and the crankcase.

Prior to using this seal tool kit, follow these steps on plunger pumps. Follow the instructions in the pump service manual or 35 Frame Seal Service Videos.

### Draining the Oil; Removal of Manifolds, Plungers and Plunger Retainers:

1. Remove the drain plug from the rear cover of the drive end to drain the oil from the crankcase.
2. Remove the discharge manifold from the pump.
3. Remove the inlet manifold from the crankcase.
4. Remove the plunger retainer and plunger from the plunger rods.
5. Remove seal retainers, keyhole washers and slinger barriers.

**NOTE:** Oil leaks may be caused by damage to the plunger rods instead of worn or damaged oil seals. Before performing removal and replacement of the oil seals, inspect the surface of the plunger rods for nicks, scratches or other abnormal wear. Replace as needed.



Supporting Information:  
Scan with a smart phone to watch 35 Frame Service videos.  
[www.catpumps.com/service-videos](http://www.catpumps.com/service-videos)

#### KIT INCLUDES:

- |                             |                             |                         |
|-----------------------------|-----------------------------|-------------------------|
| (1) Seal Removal Tool       | (3) #10 Flat Washers        | (1) 3/16" Flat Washer   |
| (9) #8 x 3" Phillips Screws | (1) #2 x 6" Phillips Driver | (3) Crankcase Oil Seals |

**Tools Required:** Hand-held Electric Drill, Large Adjustable Wrench

### Removal of Plunger Rod Oil Seals from the Crankcase:

**NOTE:** The oil seal will be damaged during this process and must be replaced.

1. Tighten an adjustable wrench around the crankshaft, specifically on the keyway.
2. Rotate the crankshaft so the plunger rod is fully retracted into the crankcase.
3. Insert the seal tool over the plunger rod and press it back to make contact with the oil seal.

**NOTE:** Confirm that the seal tool is seated directly against the seal, completely inside the plunger rod oil seal bore (Figure 1).

4. Install a washer over the first screw and insert the screw into one of the three seal tool holes (Figure 2). Repeat with the other 2 screws.
5. Insert a long #2 Phillips bit driver into the chuck of a drill.

6. Hold onto the backside of the crankcase with one hand and use the other hand to press the driver against the screw.
7. Slowly tighten the screw into the face of the oil seal, puncturing the surface until the screw head is tight against the washer (Figure 3). Repeat steps 6–7 with the other 2 screws.

**NOTE:** If the screw does not pierce the seal, tap it gently with a hammer to penetrate the metal in the seal before using the driver.

8. Use an adjustable wrench to turn the crankshaft, pushing the plunger rod and tool outwards and pulling the oil seal out of the crankcase.
9. Remove the oil seal tool and oil seal from the plunger rod.
10. Use the drill to remove the screws from the oil seal.
11. Repeat to remove the other two oil seals if necessary.

Figure 1

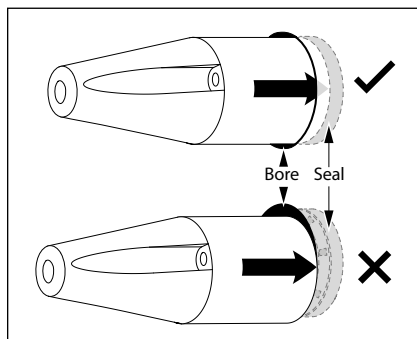

Figure 2

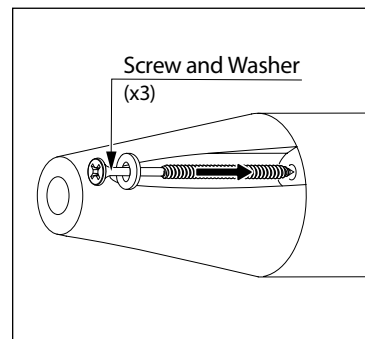
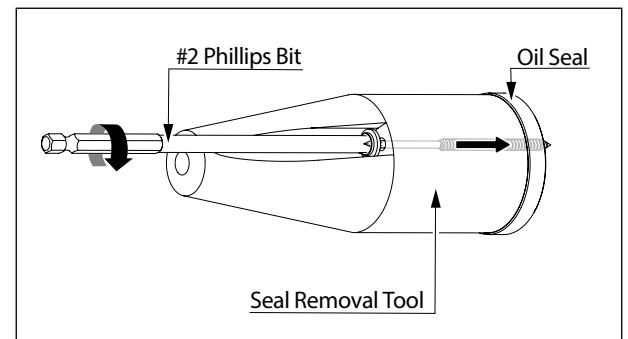

Figure 3



## Reinstallation of Oil Seals

**NOTE:** There are three different configurations depending on the pump model (Figure 4).

1. Use the adjustable wrench to turn the crankshaft so the plunger rod is extended as far as possible.
2. Wipe the plunger retainer and crankcase oil seal bore clean with a clean towel.
3. Put some light assembly oil or grease on the inside diameter of the new oil seal.
4. Install the oil seal over the plunger rod and press it back into the crankcase bore by hand.
5. Insert the seal tool over the plunger rod and press it back towards the oil seal (Figure 5).
6. Install the plunger retainer on the rod and hand-tighten it against the tool.
  - a. For most models, the plunger retainer diameter is larger than the hole in the seal tool. The bottom of the plunger retainer will sit against the top edge of the seal tool.
  - b. For models 3550 and 3560, install the plunger retainer on the rod and hand-tighten it into the bore so the head of the plunger retainer seats against the top edge of the seal tool.
  - c. For models 3501HS, 3507HS and 3801HS, install the flat washer included with the kit over the plunger rod before installing the plunger retainer. The bottom of the retainer will sit against the washer.
7. Use the adjustable wrench to turn the crankshaft, pulling the plunger rod and tool inwards and pushing the oil seal into the crankcase.
8. Remove the plunger retainer and oil seal tool from the plunger rod.
9. Repeat to install the other two oil seals if necessary.

Figure 4

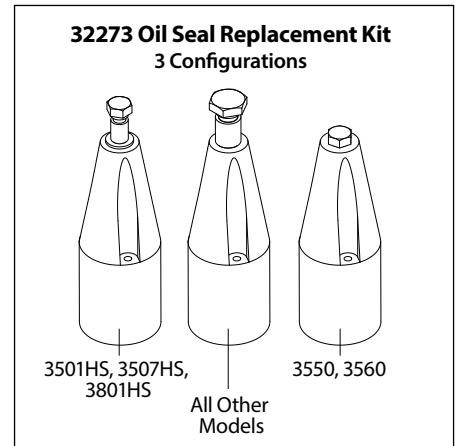
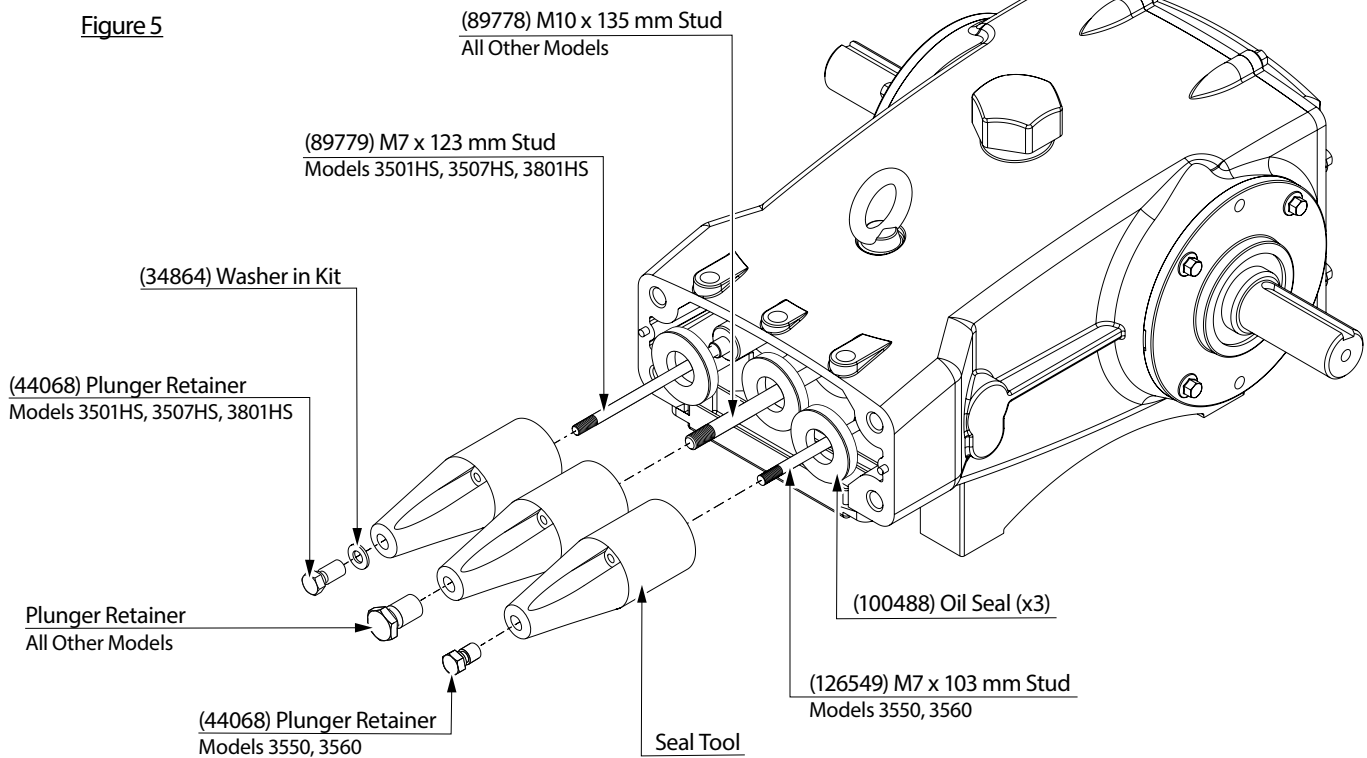

Figure 5



## Cat Pumps

Technical Services Department