

DATA SHEET

POP-OFF VALVES



Brass Model: **9940**

**Stainless Steel
Model:** **9941**



Model 9940 Shown

FEATURES

- Provides backup protection as a secondary pressure relief device to ensure complete pressure relief for maximum pump and system protection.
- Lightweight, compact design quickly and conveniently mounts directly into discharge line.
- Comes standard with NBR O-rings. Alternative O-ring materials are available for higher temperatures or chemical compatibility.

SELECTION

Select a pop-off valve to meet or exceed the flow and pressure requirements of the system.

INSTALLATION

The pop-off valve should mount to the discharge port of the pump manifold, opposite from the primary pressure regulating device. If unavailable, plumb the pop-off valve parallel to the high-pressure line upstream from the primary pressure regulating device. The bypass flow from the pop-off valve should be left open or drained to the floor. If the pop-off valve opens and relieves, the bypassing fluid needs to be visible to the operator so the cause of the relief can be addressed. Do not route the bypass flow from the pop-off valve back to a reservoir or the pump's inlet.

OPERATION

This pop-off valve provides backup protection to the primary pressure regulating device for complete pressure relief and maximum pump and system protection.

Note: The pop-off valve is a secondary pressure relief device. It does not replace a primary pressure regulating device like a pressure regulator or unloader.

SPECIFICATIONS

	U.S. Measure	Metric Measure
Flow Range	0–25 gpm	0–95 lpm
System Pressure Range	1000–4000 psi	69–275 bar
Maximum Relief Setting	4400 psi	303 bar
Maximum Temperature (NBR)	180° F	82° C
Inlet Port	¾" NPT(M)	¾" NPT(M)
Adjusting Hose Barb	1.0"	1.0"
Weight	9.6 oz	.27 kg
Dimensions	1.125 x 3.500"	28.6 x 88.9 mm

ALTERNATIVE O-RING CONFIGURATION

MATERIAL	SUFFIX CODE	MAXIMUM TEMPERATURE	
NBR	—	180° F	(82° C)
FPM	.0110	240° F	(115° C)

PRESSURE ADJUSTMENT

Setting and adjusting the primary pressure regulating device and pop-off valve must be done while the system is running. Set the primary pressure regulating device to its minimum setting by turning the adjusting barb counter-clockwise.

On the pop-off valve, hand-thread the lock nut towards the ¾" NPT(M) inlet port and slide the O-ring down to the lock nut. Turn the adjusting barb clockwise to the highest pressure setting, then counter-clockwise slightly, so the valve is not bottomed out.

With the system on and running, actuate the flow downstream. Adjust the primary pressure regulating valve clockwise to increase the system operating pressure to desired set point.

Note: If there is visible water coming from the pop-off valve bypass port during this process, continue to increase its setting.

While the system is operating at full pressure, slowly turn the pop-off valve's adjusting barb counter-clockwise until a small amount of water is dripping from it. Adjust a half-turn clockwise until the dripping stops; no more than three half-turns should be required. Cycle the downstream flow on and off to check for any leaks. A closing trigger gun or solenoid valve may create a pressure spike and cause the pop-off valve to leak. Re-adjust as necessary. Slide the O-ring up to the adjusting barb. Hand-thread the lock nut up to the O-ring and the adjusting barb to compress. The pop-off valve is now set approximately 200 to 300 psi over the system pressure.

PARTS LIST

ITEM	DESCRIPTION	9940 BB		9941 SS		QTY
		P/N	MATL	P/N	MATL	
1	Seat	31205	S	76567	SS	1
2	O-Ring, Seat	32008	NBR	32008	NBR	1
		33562	FPM	33562	FPM	1
3	Spring, Pressure	33329	STZP	994778	S	1
4	Body, Inlet (3/4" NPT[M])	—	BB	—	SS	1
5	Ring, Retaining	76529	SSS	76529	SSS	1
6	Spacer, Seat	76530	BB	76570	SS	1
7	Nut, Lock	76531	BB	76571	SS	1
8	Barb, Adjusting (1")	—	BB	—	SS	1
9	Retainer, Spring with Ball	76533	BB	76573	SS	1
10	O-Ring, Barb-80D	44001	NBR	44001	NBR	1

Bold part numbers are unique to a particular model.

Material Codes (Not Part of Part Number):

BB=Brass FPM=Fluorocarbon NBR=Medium Nitrile

S=304SS SS=316SS SSS=416SS

STZP=Steel/Zinc Plated

TYPICAL POP-OFF VALVE INSTALLATION

1. Triplex Plunger Pump
2. Pulsation Dampener
3. **Pop-Off Valve**
(Secondary Pressure Relief Device)
4. Pressure Gauge
5. Pressure Regulator
(Primary Pressure Regulating Device)

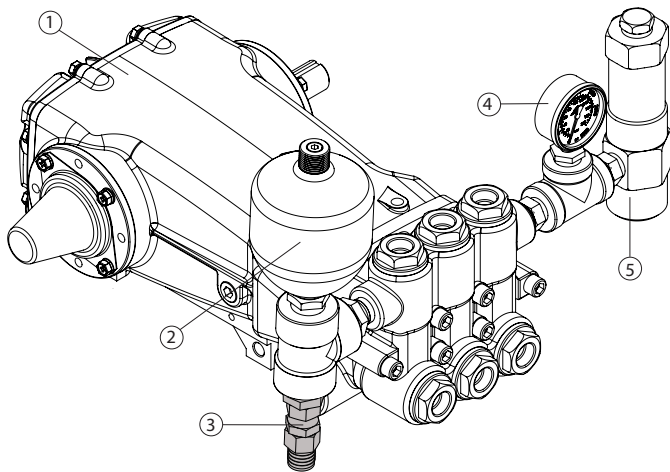

EXPLODED VIEW

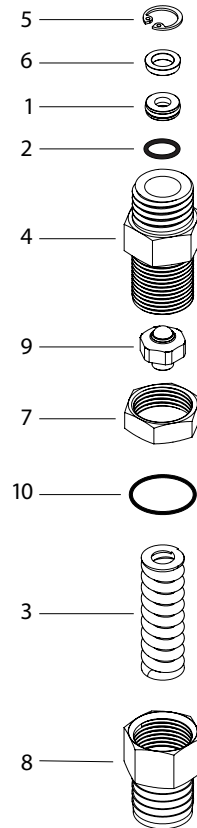

TROUBLESHOOTING

Valve cycles	<ul style="list-style-type: none"> Valve is improperly set Repeat adjustment procedure
Valve continually bypasses	<ul style="list-style-type: none"> Seat or retainer is worn Replace as needed

⚠ CAUTIONS AND WARNINGS

All high-pressure systems require a primary pressure regulating device (e.g. regulator, unloader) and a secondary pressure relief device (e.g. pop-off valve, relief valve). Failure to install such relief devices could result in personal injury or damage to pump or property. Cat Pumps does not assume any liability or responsibility for the operation of a customer's high-pressure system.

Read all CAUTIONS and WARNINGS before commencing service or operation of any high-pressure system. The CAUTIONS and WARNINGS are included in each Service Manual and with each Accessory Data sheet. CAUTIONS and WARNINGS can also be viewed online at www.catpumps.com/dynamic-literature/cautions-and-warnings or can be requested directly from Cat Pumps.

WARRANTY

View the Limited Warranty online at www.catpumps.com/literature/cat-pumps-limited-warranty