

DATA SHEET

NEMA BELL HOUSINGS AND FLEXIBLE COUPLERS



**Bell Housing
Models:**

76215.15FR, 76256.15FR, 76286.15FR

**Flexible Coupler
Models:**

8382, 8383, 8388

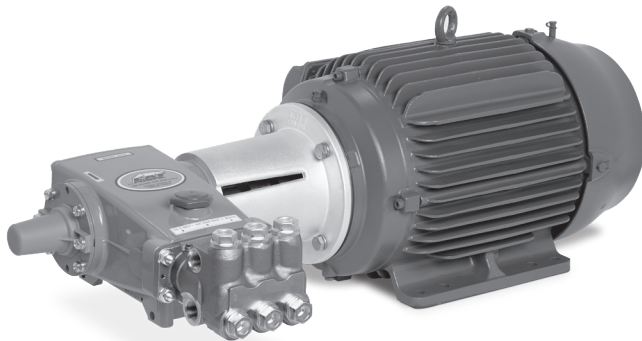

Bell Housing Assembly and Flexible Coupler Assembly
(Model 660 and electric motor sold separately)

FEATURES

- Bell housing design eliminates the need of belt selection, sizing and adjustments.
- Creates optimal shaft alignment, which reduces side-loading for quiet, trouble-free operation.
- Bell Housing is cast from lightweight, high-strength aluminum alloy.
- Compact direct mounting design reduces the space required compared to belt or gearbox drive assemblies.
- Ease of assembly reduces fabrication costs.
- Available as a completely assembled unit from Cat Pumps for fast and convenient assembly or as individual components.
- Designed to fit 15 and 18 Frame pumps.

PARTS LIST

Bell Housing Assemblies

Pump Series	Models	NEMA Type	Bell Housing Assemblies
15 & 18FR	All 15 & 18FR Models	213/215TC	76215.15FR
		254/256TC	76256.15FR
		284/286TC	76286.15FR

76215.15FR & 76256.15FR includes bell housing and mounting hardware.

76286.15FR includes bell housing, flange adapter and mounting hardware.



76215.15FR Bell Housing Assembly Shown



76286.15FR Bell Housing Assembly Shown

PARTS LIST

Flex Coupler Assemblies

	8388	8382	8383
Motor Frame	213/215TC	254/256TC	284/286TC
Shaft to Shaft Dimensions	M30 to 1 $\frac{3}{8}$ "	M30 to 1 $\frac{5}{8}$ "	M30 to 1 $\frac{7}{8}$ "
Coupler Half, Motor	996671	31543	996693
Coupler Half, Pump	996672	996672	996692
Pump shaft Key	8 mm	8 mm	8 mm
Key, Pump	990036	990036	990036
Spyder	31544	31544	996694
Spyder (Color)	Purple	Purple	Purple
Torque Rating	150 ft-lbs	150 ft-lbs	150 ft-lbs



8382 Coupler Shown

INSTALLATION

NEMA Bell Housing and Flexible Coupling

1. Separate the parts included in the bell housing and/or flexible coupler assembly packages. Both assemblies are offered in separate kits to cover the various torque ratings and pump models.
 2. Remove the bearing cover screws from the extended shaft side of the pump and discard the screws. New screws are supplied in the bell housing assembly.
 3. From the side where the bearing cover screws are removed, slide the small end of the bell housing over the pump shaft with the Cat Pumps logo facing up and positioned 22° from the top.
 4. Install conical lock washers. Apply Loctite® 242® to the threads of the screws provided in the assembly and torque to 115 in-lbs, 13 N-m for M8 screws in an alternating rotation.
 5. Apply a light film of anti-seize lubricant to the pump shaft
 6. Install the key on the pump shaft.
 7. Separate 30mm half of the flexible coupler with the spyder.
 8. Remove one (1) cross-clamp screw from the 30mm coupler half. Apply Loctite® 242® to the threads and then reinstall into the coupler half.
 9. Slide the 30mm coupler half onto the pump shaft. Align inner face of the coupler flush with the end of the crankshaft.
 10. Insert a 6mm or 8mm hex wrench into the cross-clamp screw and tighten enough to hold the key and coupler in place. Tighten this screw to torque specifications in the final step.
 11. On the 284/286TC frame bell housing assemblies, mount the flange adapter with the raised and finished surface away from the motor. Apply Loctite® 242® to the threads of the four (4) ½" screws and torque to 300 in-lbs, 25 N-m.
- Note:** The 213/215TC and the 254/256TC frame bell housing assemblies do not include an additional adapter plate.
12. Apply a light film of anti-seize lubricant to the motor shaft.
 13. Install the motor key (supplied with motor) onto the motor shaft keyway.
 14. Remove one (1) cross-clamp screw from the motor coupler and apply Loctite® 242® to the threads of the screw and then reinstall into coupler half.
 15. Slide the motor half of the flexible coupler containing the spyder onto the motor shaft.
 16. Mount the pump with the bell housing and coupler half onto the coupler half of the motor, lining up the two halves.
 17. Apply Loctite® 242® to the threaded area of the bolts, slip lock washers onto bolts and thread through the flange into the motor. Torque to 300 in-lbs, 34 N-m for ½" bolts.
 18. To secure flexible coupling with cross-clamp screws, insert a screwdriver into the bell housing and press the flexible coupler towards the pump.
- Note:** Flexible coupler halves should not contact each other. Ensure there is a small gap between the two coupler halves.
19. Rotate the motor shaft so cross-clamp screw are lined up with bell housing opening.
 20. Insert a 6mm or 8 mm hex wrench into each cross-clamp screw and torque to 300 in-lbs, 34 N-m for M8 cross-clamp screw, or 600 in-lbs, 68 N-m for M10 clamping screws.

Loctite and 242 are registered trademarks of the Henkel Corporation.

Torque Specifications Chart

Screw	Thread Size	Tool	in-lbs	ft-lbs	N-m
Bell Housing to Pump	M8	5 mm Hex Wrench	115	9.6	13
Bell Housing to Motor	½"	¾" Combination Wrench	300	25	34
Adapter Plate to Motor (76286.15FR)	½"	¾" Hex Wrench	300	25	34
Flexible Coupler Cross-Clamp Screw	M8	6 mm Hex Wrench	300	25	34
	M10	8 mm Hex Wrench	600	50	68

DIMENSIONAL DRAWINGS

Bell Housing Assemblies

Model	Motor Frame	A	Ø B	C (BC)	QTY	Ø D	E (BC)	QTY	Ø F
76215.15FR	213/215TC	5.92"	.565"	7.25"	4	.335"	4.13"	8	8.50"
76256.15FR	254/256TC	6.92"	.565"	7.25"	4	.335"	4.13"	8	8.50"
76286.15FR	284/286TC	7.87"	.565"	9.00"	4	.335"	4.13"	8	10.50"

76286.15FR

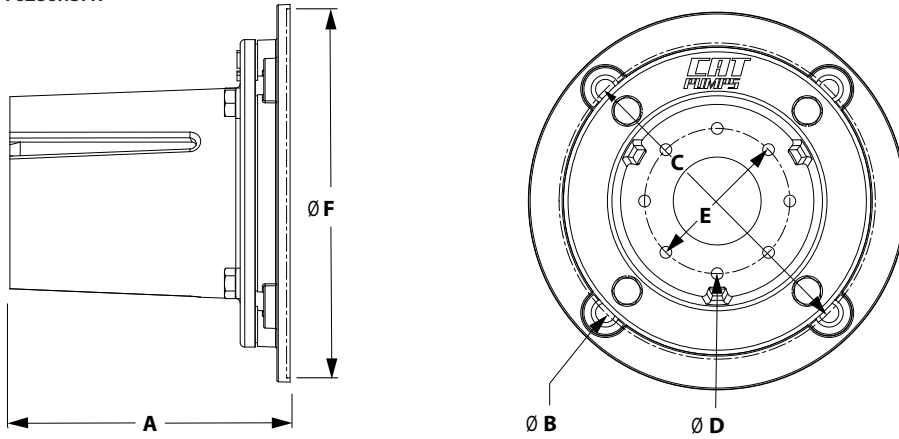

Flexible Coupler Assemblies

Model	Ø A	B	C	D
8382	3.15"	4.41"	.86"	1.77"
8383	3.15"	4.41"	.86"	1.77"
8388	3.74"	4.96"	1.02"	1.97"

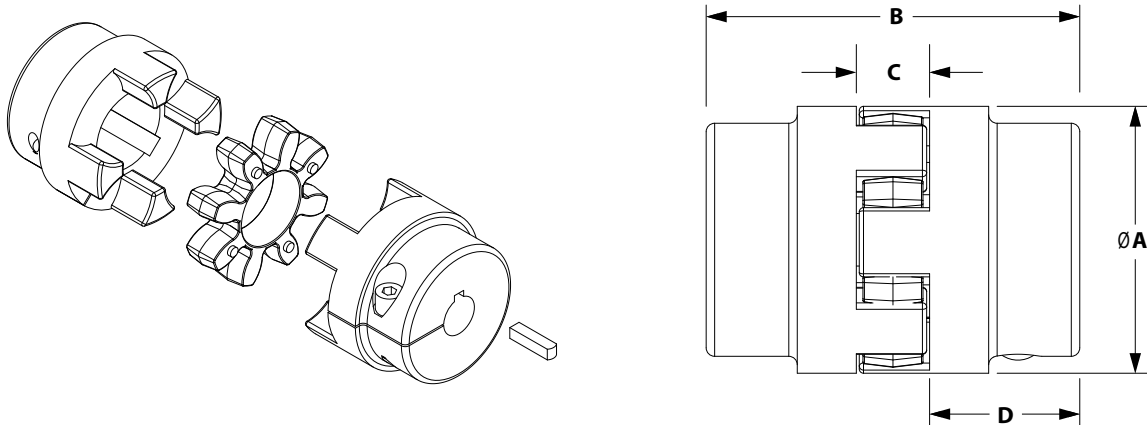

⚠ CAUTIONS AND WARNINGS

All high-pressure systems require a primary pressure regulating device (e.g. regulator, unloader) and a secondary pressure relief device (e.g. pop-off valve, relief valve). Failure to install such relief devices could result in personal injury or damage to pump or property. Cat Pumps does not assume any liability or responsibility for the operation of a customer's high-pressure system.

Read all CAUTIONS and WARNINGS before commencing service or operation of any high-pressure system. The CAUTIONS and WARNINGS are included in each Service Manual and with each Accessory Data sheet. CAUTIONS and WARNINGS can also be viewed online at www.catpumps.com/dynamic-literature/cautions-and-warnings or can be requested directly from Cat Pumps.

WARRANTY

View the Limited Warranty online at www.catpumps.com/literature/cat-pumps-limited-warranty