

# DATA SHEET

## MODULAR PRESSURE-SENSITIVE UNLOADER



**Brass Model:**     **7860** with Injector for 66DX Series



### FEATURES

- Provides system pressure regulation and protection for single pump and non-weep gun installations.
- Built-in bypass channel ensures the safety of the low-pressure bypass flow when the trigger gun is shut off.
- Convenient flow-through screws allow easy, direct mounting to the pump.
- The pressure-sensitive feature provides immediate pressure when the trigger gun handle is squeezed.
- The grooved plastic handle permits easy pressure adjustment.
- Fixed chemical injector aids in cleaning flexibility.

### SPECIFICATIONS

#### Unloader

	U.S.	Metric
Flow Range	3.0–5.0 gpm	11.4–19.0 lpm
Pressure Range	700–4000 psi	50–276 bar
Maximum Temperature	160° F	71° C
Inlet Port (1)	½" NPT(F)	½" NPT(F)
Outlet Port (1)	¾" NPT(M)	¾" NPT(M)
Bypass Port	Built-In Channel	Built-In Channel
Weight	2.20 lbs	1.0 kg
Dimensions	4.50 x 1.38 x 6.50"	114 x 35 x 165 mm

### SPECIFICATIONS

#### Chemical Injector

	U.S.	Metric
Flow Range	3.0–5.0 gpm	11.4–19.0 lpm
Nozzle Orifice	2.1 mm	2.1 mm
Inlet Port	M20 x 1	M20 x 1
Discharge Port	¾" NPT(M)	¾" NPT(M)
Weight	0.25 lbs	0.11 kg
Dimensions	1.75 x 1.00 x 2.12"	44 x 254 x 54 mm

## Read all CAUTIONS and WARNINGS before commencing service or operation of any high-pressure system

### SELECTION

This pressure-sensitive regulating unloader is designed for systems with a single pump, solenoid (gate) valve, nozzle and shut-off gun. Weep guns are not recommended with these unloaders.

**Note:** For multiple-pump systems, it is best to use a pressure regulator, not a pressure-sensitive regulating unloader.

This unloader must meet both the desired system flow (combined nozzle flow rate requirement) and the desired system pressure.

**NOTICE** Operation below the minimum rated flow of the unloader causes the unloader to cycle. Operation above the maximum rated flow of the unloader causes cycling and premature wear, preventing achieving the desired system pressure.

### INSTALLATION

This pressure sensitive regulating unloader mounts directly to the side inlet and discharge ports of the 66DX Series plunger pumps. The unloader is held in place by one ½" NPT(M) flow-through screw on the bottom and one ¾" NPT(M) flow-through screw at the top.

**Note:** There are two seal washers for each port size. One seal washer is mounted between pump manifold and unloader body and the other is located between unloader body and under the head of the flow-through screw.

The inlet connection of this unloader has a ½" NPT(F) sized port and is located on the bottom. There is an arrow cast into the body indicating the direction of flow. The water supply connects here.

The discharge connection of this unloader with the chemical injector installed is a ¾" NPT(M) sized port. An arrow with the word OUT is cast into the body indicating the direction of flow. Without the chemical injector the unloader port size is M18. Plumbing for the spray gun, solenoid (gate) valve or nozzle connects here.

There is no bypass connection for this unloader; this unloader has a built-in channel for internal bypass.

### OPERATION

This unloader holds the established system pressure in the discharge line when the trigger gun or solenoid (gate) valve is closed or the nozzle is clogged, thus bypassing all unrequired flow. Squeezing the trigger gun or opening the solenoid (gate) valve will close off the bypass and return to established system pressure.

### PRESSURE ADJUSTMENT

#### Setting the Primary Pressure Regulating Device

**Note:** Pressure is not set at the factory

1. Setting and adjusting the primary pressure regulating device and relief valve must be done while the system is running.
2. Start the system with the unloader backed off to the lowest pressure setting (counterclockwise direction)
3. Increase the unloader pressure setting by turning the adjusting handle clockwise.
4. Squeeze the trigger and read the pressure on the gauge at the pump.  
**Note:** Do not read the pressure at the gun or nozzle.
5. If more pressure is desired, release the trigger, turn adjusting handle one quarter turn in a clockwise direction.
6. Squeeze the trigger and read the pressure.
7. Repeat this process until desired system pressure is reached.

**NOTICE** A secondary pressure safety relief device (e.g. pop-off valve, relief valve) should be used along with this pressure-sensitive regulating unloader. Final adjustment for the secondary relief valve should be approximately 200 psi above the system operating pressure.

**Note:** A minimum of 5% of the flow-through the unloader should bypass for proper unloader performance. If the entire unloader flow pumps through the nozzle (zero-bypass), the valve can easily be set for pressure higher than the desired pressure, causing a malfunction or premature wear.

### TYPICAL UNLOADER INSTALLATION 66DX Series Pumps

1. Pressure Gauge
2. Pop-Off Valve  
(Secondary Pressure Relief Valve)
3. Thermal Valve
4. **Fixed Chemical Injector**
5. Garden Hose Fitting (¾" GHF x ½" NPT[M])
6. **Pressure Sensitive Regulating Unloader**  
(Primary Pressure Regulating Device)
7. ½" NPT(M) Flow-Through Screw
8. ¾" NPT(M) Flow-Through Screw
9. Triplex Plunger Pump

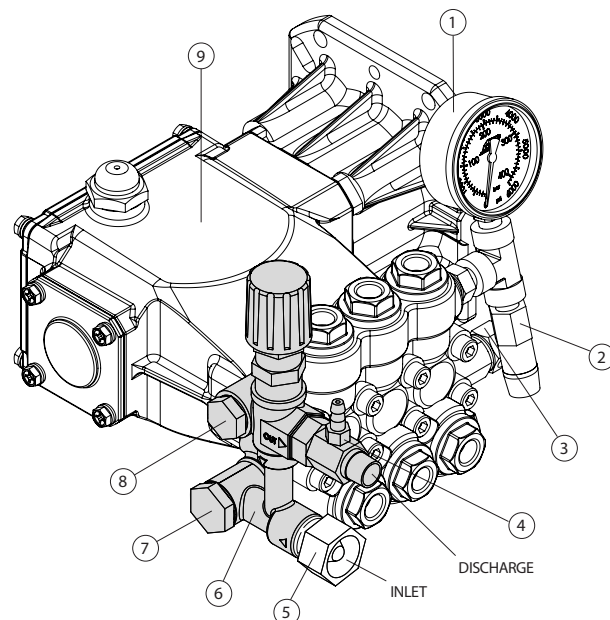

## SERVICING

### Disassembly:

1. Disconnect inlet and discharge plumbing from unloader.
2. Remove unloader from pump by unthreading inlet and discharge flow-through screws.
3. Remove black adjusting handle.
4. Loosen M4 set screw on locking nut and turn locking nut in a clockwise direction away from brass adjusting cap.
5. Remove brass adjusting cap by turning in a counterclockwise direction.
6. Remove locking nut.
7. Pull exposed spring and spring retainer from unloader body. Examine spring for fatigue or breaks and replace as needed.
8. Using a wrench, unthread piston retainer with O-ring from unloader body. Examine O-ring for cuts or wear and replace as needed.

**Note:** The piston stem and valve/ball assembly will either come out as one assembly when removing the piston retainer or will remain in unloader body.

9. Unthread the piston stem from valve/ball assembly by securing valve/ball assembly with pliers and placing screwdriver into slotted head of piston stem. Remove washer and valve retainer with O-rings and backup rings.

**NOTICE** Exercise extreme caution to avoid contact and damage to the tapered surface of the valve/ball.

10. Remove lower body manifold from the unloader body.
11. From the lower portion of the unloader body, use a tool to press out the seat and O-ring. Examine seat for grooves, pitting or wear and replace as needed. Examine O-ring for cuts or wear and replace as needed.
12. Unthread chemical injector from unloader body.
13. Remove O-ring, check valve with O-ring and spring. Examine check valve and spring for fatigue and wear and replace as needed. Examine O-rings for cuts or wear and replace as needed.

### Reassembly:

1. Before installing a chemical injector, inspect sealing area where the check valve makes contact within the internal body of the unloader for grooves, pitting and wear. If unloader surfaces are damaged, stop the repair and discard unloader and install a completely new unloader onto pump. If undamaged, proceed with step 2.
2. Place spring on end of check valve without O-ring. Install assembly into chemical injector.
3. Apply Loctite® 609 to threads of chemical injector. Thread chemical injector into body of unloader.
4. Lubricate and press seat with O-ring into unloader body. Tapered surface of seat must face down into unloader body.
5. Lubricate and install O-ring over slotted head of piston stem, then position backup ring on top of O-ring.
6. Lubricate and install larger O-ring around outside diameter of valve retainer and smaller O-ring on the inside diameter of valve retainer. Install backup ring below O-ring on inside diameter of valve retainer.
7. Place washer, then valve retainer with O-rings onto piston stem. Apply Loctite® 242® to threads of piston stem and screw into valve/ball assembly.
8. Insert complete piston stem and valve/ball assembly into unloader chamber with valve/ball assembly facing down and slotted head of piston stem facing up.
9. Apply Loctite® 609 to threads of piston retainer and hand thread into unloader body. Then tighten with wrench.
10. Place spring retainer on top of piston stem head and then install spring. Larger diameter towards spring.
11. Thread locking nut and brass adjusting cap onto retainer.
12. Re-install M4 set screw, but do not tighten until system pressure is set.
13. Place black adjusting handle over brass adjusting cap.
14. Re-install unloader onto pump by using 3/8" and 1/2" flow-through screws and seal washers.
15. Reconnect inlet and discharge plumbing to unloader.
16. Proceed to PRESSURE ADJUSTMENT to set system pressure.

Loctite and 242 are registered trademarks of the Henkel Corporation.

## CHEMICAL INJECTOR PERFORMANCE CHART

Pump Model	Pump Flow (GPM)	Unloader Model	Orifice Size (MM)	Pressure Drop Across Orifice (PSI)	Maximum Injecting Pressure (PSI)	Maximum Chemical Draw (oz/min)
66DX40G11	4.0	7860	2.1	288	358	76.8
66DX35G11	3.5	7860	2.1	245	260	74.2
66DX30G11	3.0	7860	2.1	136	190	70.0

Optimum performance of chemical injector occurs with a 35 ft high-pressure hose with a minimum 3/8" ID. The type of hose, extended lengths, reduced ID and fittings may create additional back pressures above the maximum injecting pressure rating of the injector and prevent it from drawing chemical.

## PARTS LIST

ITEM	P/N	MATL	DESCRIPTION	QTY
401	49100	NY	Handle, Adjusting (Black)	1
402	49099	BB	Cap, Adjusting	1
403	125521	BB	Nut, Locking (M25 x 1)	1
404	88953	S	Screw, Set (M4 x 4)	1
408	45198	ZP R	Spring, Pressure	1
410	49101	STZP R	Retainer, Spring	1
412	49103	S	Stem, Piston	1
414	129638	PTFE	Backup Ring, Piston Stem	1
415	49104	NBR	O-Ring, Piston Stem-90D	1
423	49105	BB	Retainer, Valve	1
424	49106	NBR	O-Ring, Valve Retainer-70D	1
425	49102	BB	Retainer, Piston	1
426	49107	S	Washer	1
428	26133	NBR	O-Ring, Piston Retainer-80D	1
429	22056	NBR	O-Ring, Valve Retainer-70D	1
430	49123	D	Backup Ring, Valve Retainer	1
435	49383	S	Valve/Ball Assembly	1
436	49384	S	Seat	1
437	13965	NBR	O-Ring, Seat-70D	1
440	—	BB	Body	1
442	49121	STL	Washer, Seal (3/8")	2
443	49245	BB	Valve, Check with NBR O-Ring	1
444	117275	S	Spring, Check Valve	1
446	26113	NBR	O-Ring, Body-80D	1
454	11346	NBR	O-Ring, Manifold-70D	1
456	—	BB	Manifold, Lower Body	1
460	126974	BB	Fitting, Discharge (3/8" NPT(M))	1
462	49120	BB	Screw, Flow-Through (3/8" NPT(M))	1
463	49117	BB	Screw, Flow-Through (1/2" NPT(M))	1
464	49118	STL	Washer, Seal (1/2")	2
468	31708	NBR	Kit, O-Ring (Includes: 414, 415, 424, 428, 429, 430, 437, 446, 454)	1
469	7367	BB	Injector, Chemical Fixed	1
470	31556	NBR	Kit, Repair (Includes: 412, 414, 415, 423-426, 428-430, 435-437)	1
471	76185	NBR	Kit, Check Valve (Includes: 443, 444, 446)	1
472	49132	BB	Barb, Fix	1
473	—	—	Gasket	1
476	—	NBR	O-Ring	1
477	—	S	Ball	1
478	—	S	Spring	1
479	—	S	Orifice	1
480	—	BB	Body	1
483	76176	NBR	Kit, Repair, Chemical Injector (Includes: 476, 477, 478)	1

## EXPLODED VIEW

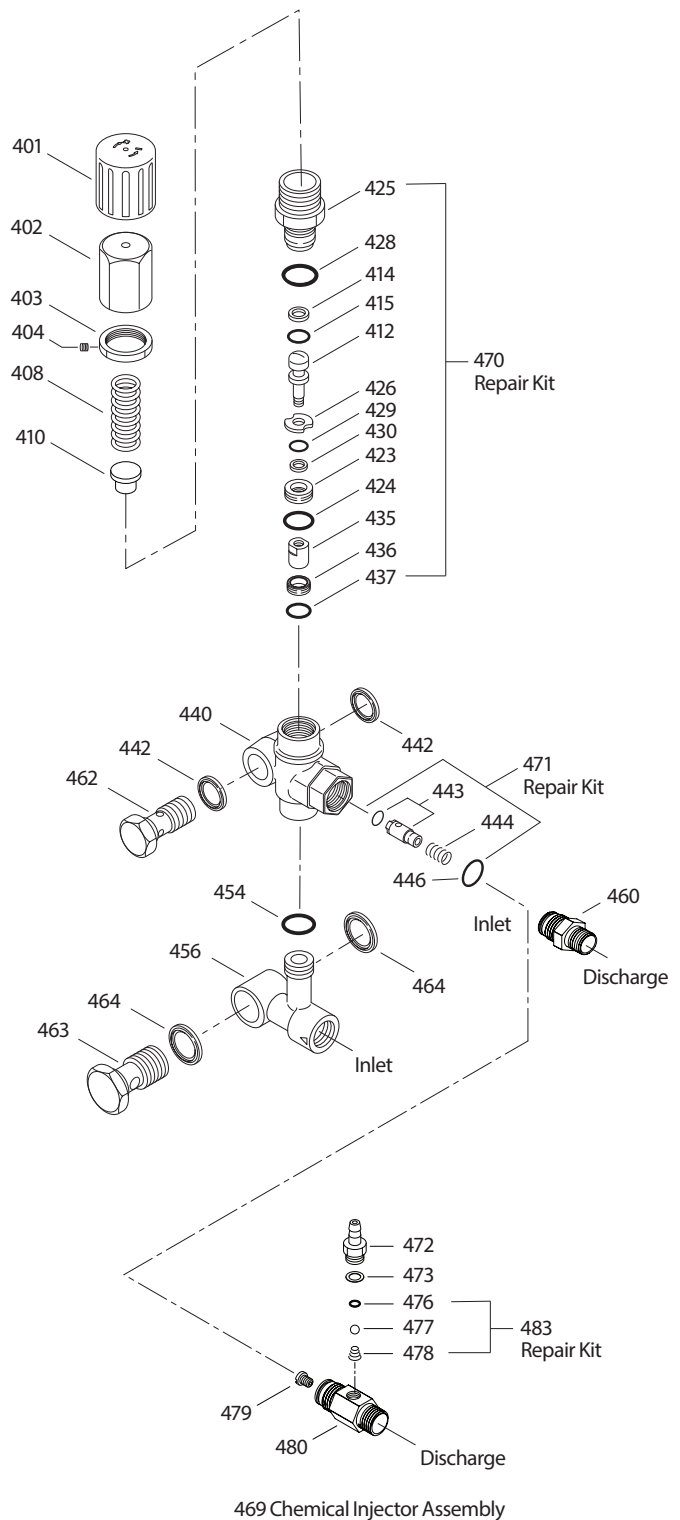

## TROUBLESHOOTING

Unloader cycles	<ul style="list-style-type: none"> <li>Worn O-ring or check valve</li> <li>Fitting leaking downstream</li> <li>O-ring in gun worn</li> </ul>
Liquid leaking from bottom	<ul style="list-style-type: none"> <li>O-ring for seat or inlet fitting seal washer cut or worn</li> </ul>
Unloader will not come up to pressure	<ul style="list-style-type: none"> <li>Unloader not properly sized for system</li> <li>Foreign material in unloader</li> <li>Piston or retainer O-rings worn or cut</li> <li>Nozzle worn</li> <li>Nozzle not properly sized for system</li> </ul>
Extreme pressure spikes	<ul style="list-style-type: none"> <li>Adjusting cap turned completely into unloader</li> <li>Restricted bypass or no bypass</li> <li>System flow exceeds unloader rating</li> <li>Locking nut not properly set</li> </ul>

### ⚠ CAUTIONS AND WARNINGS

All high-pressure systems require a primary pressure regulating device (e.g. regulator, unloader) and a secondary pressure relief device (e.g. pop-off valve, relief valve). Failure to install such relief devices could result in personal injury or damage to pump or property. Cat Pumps does not assume any liability or responsibility for the operation of a customer's high-pressure system.

Read all CAUTIONS and WARNINGS before commencing service or operation of any high-pressure system. The CAUTIONS and WARNINGS are included in each Service Manual and with each Accessory Data sheet. CAUTIONS and WARNINGS can also be viewed online at [www.catpumps.com/dynamic-literature/cautions-and-warnings](http://www.catpumps.com/dynamic-literature/cautions-and-warnings) or can be requested directly from Cat Pumps.

### WARRANTY

View the Limited Warranty online at [www.catpumps.com/literature/cat-pumps-limited-warranty](http://www.catpumps.com/literature/cat-pumps-limited-warranty)