

DATA SHEET

VERTICAL MULTISTAGE PUMP



**Stainless Steel
Model:**

810K11S9T3F



SPECIFICATIONS

Size

Suction	300# ANSI Raised Face 2"
Discharge	300# ANSI Raised Face 2"
HP	10.0 hp
RPM	3450 rpm

Liquid Handled

Type of Liquid	**Clean Water
Temperature Range	-22°–248°F (-30°–120°C)
Max. Working Pressure	375 psi (25 bar)

Materials

Impeller	AISI 304
Intermediate Casing	AISI 304
Bottom Casing	AISI 304
Casing Cover	AISI 304
Outer Casing	AISI 304
Shaft	AISI 304
Liner Ring	PPS/AISI 304
Motor Bracket	Cast Iron
Base	Die Cast Aluminum
Lower Pump Bearings	Tungsten Carbide
Mechanical Seal	Silicon Carbide/Carbon/FPM

Motor

Type	NEMA 215TC Frame, TEFC
Speed	60 Hz, 3450 RPM (2 Poles)
Three Phase	*230/460V
Direction of Rotation	Clockwise When Viewed from Motor End

Weight

Pump	78.9 lbs
Motor	122 lbs

* Prior to Department of Energy (DOE) EERE-2020-BT-TP-0011 motor was name-plated rated 208–230 Volt.

** For other clean liquids, consult Cat Pumps.

Note: See PN 99SVM001 for complete operating instructions, installation and maintenance manual information.

PERFORMANCE CURVE – 3450 RPM

78 gpm, 575 Ft/Hd

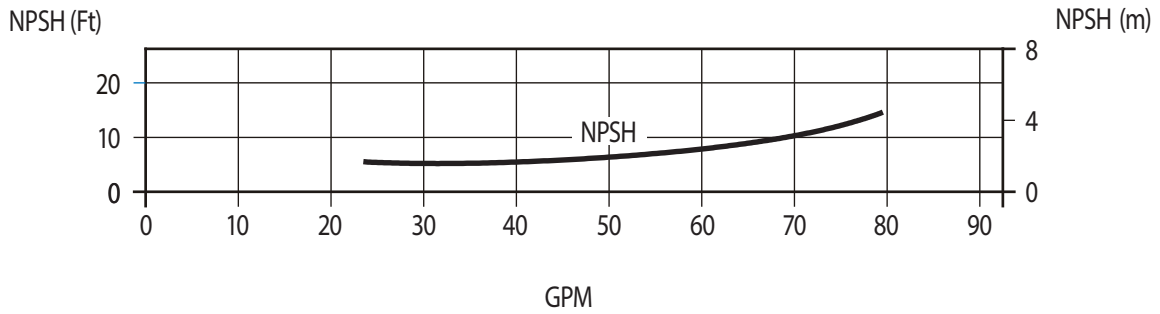
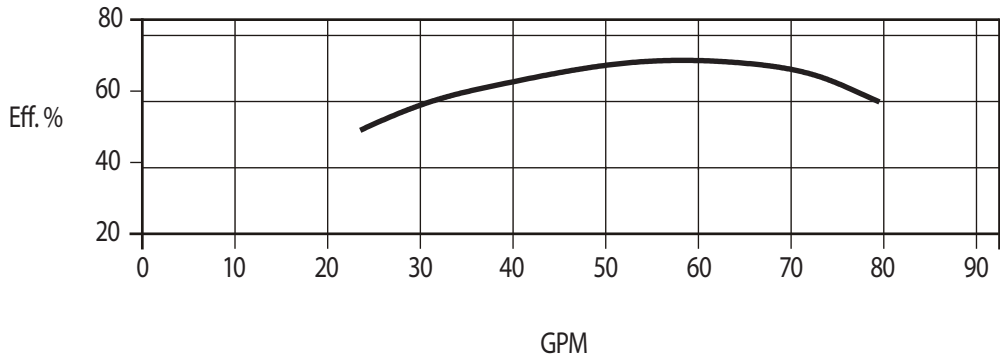
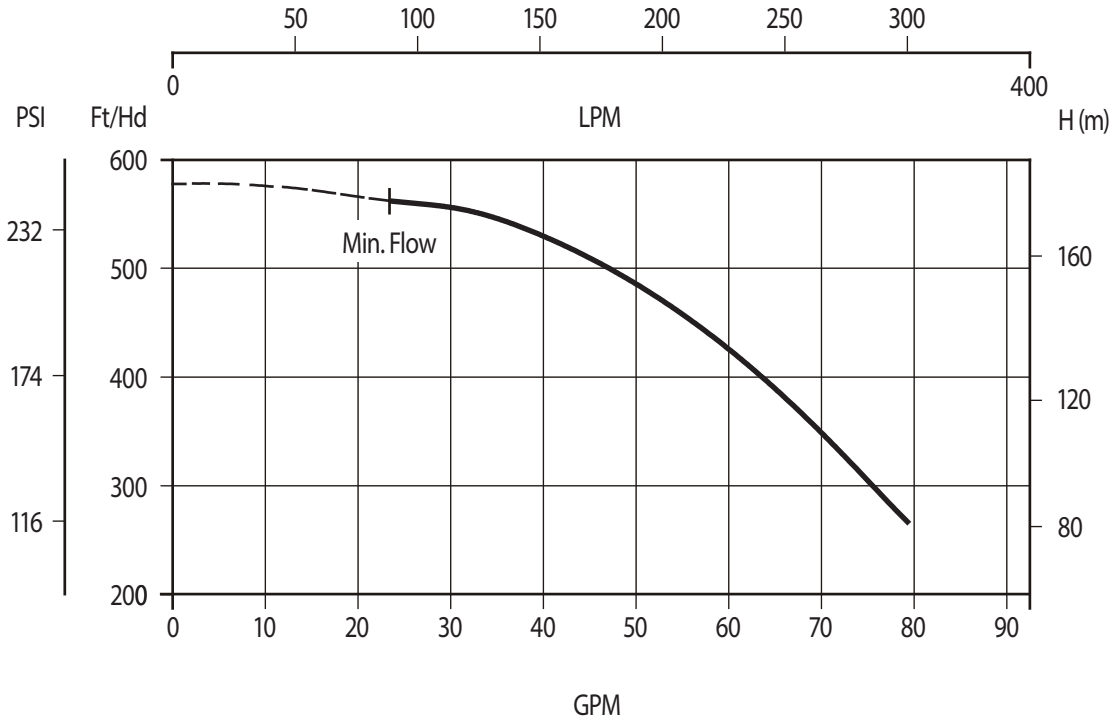

Water Temperature: 68° F (20° C)

EXPLODED VIEW

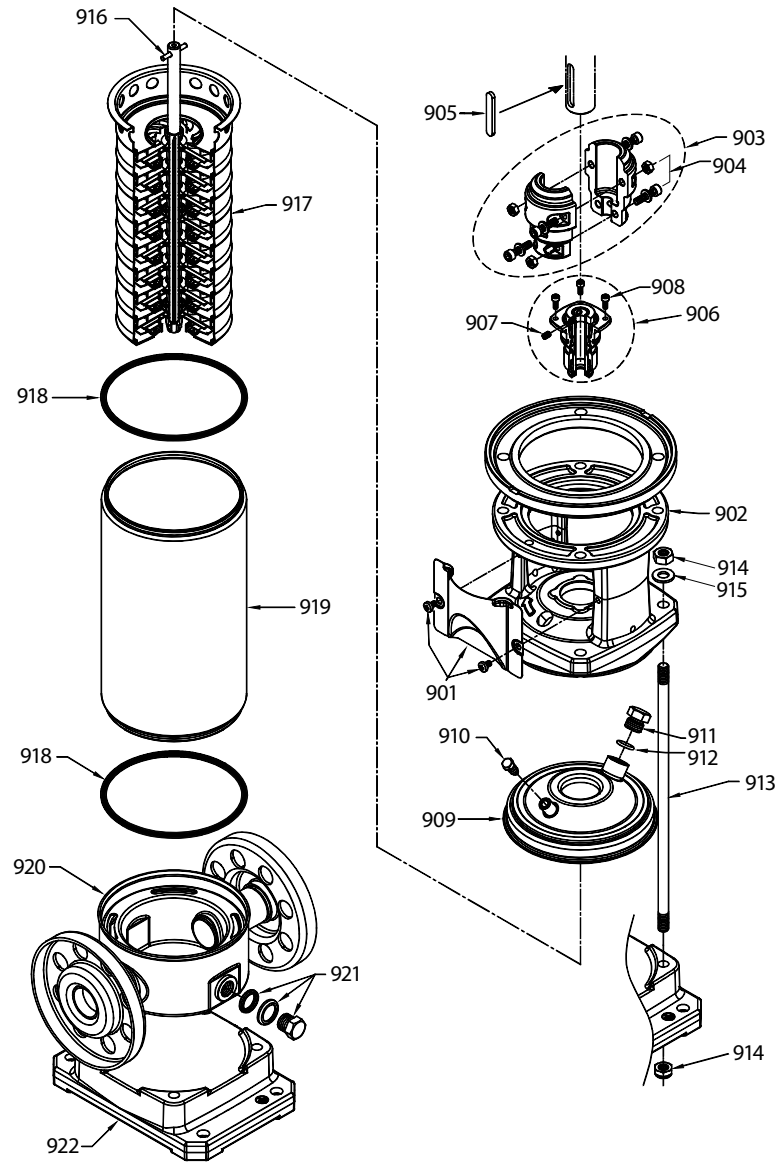

900 Motor Not Shown

PARTS LIST

ITEM	P/N	MATL	DESCRIPTION	QTY	ITEM	P/N	MATL	DESCRIPTION	QTY
900	—	—	Motor, Electric (Not Shown)	1	913	—	STZP	Rod, Tie	4
901	—	S	Assembly, Coupler Guard	2	914	—	STZP	Nut, Tie Rod	4
902	—	F	Bracket, Motor	1	915	—	STZP	Washer, Tie Rod	4
903	—	AL	Coupling (2-Piece)	1	916	—	STL	Pin, Shaft	1
904	—	STL	Hardware, Coupling (M6)	4	917	—	S	Assembly, Hydraulic	1
905	—	S	Key, Adjuster	1	918	—	FPM	O-Ring, Outer Casing	2
906	—	FSC	Seal, Mechanical	1	919	—	S	Casing, Outer	1
907	—	STL	Screw, Set	1	920	—	S	Casing, Bottom	1
908	—	STZP	Screw, Mechanical Seal Seat	4	921	—	S	Assembly, Plug, Drain	2
909	—	S	Cover, Casing	1	922	—	AL	Base	1
910	—	S	Plug, Priming	1	923	—	—	Kit, Seal (Includes: 906, 918)	1
911	—	S	Plug	1	924	—	—	Kit, Hydraulic (Includes: 905, 906, 917, 918)	1
912	—	FPM	O-Ring, Plug	1					

Italics are optional items

Material Codes (Not part of part number):

AL= Aluminum F=Cast Iron FPM= Fluorocarbon FSC= FPM with Silicon Carbide S= 304 Stainless Steel STL= Steel STZP= Steel/Zinc Plated

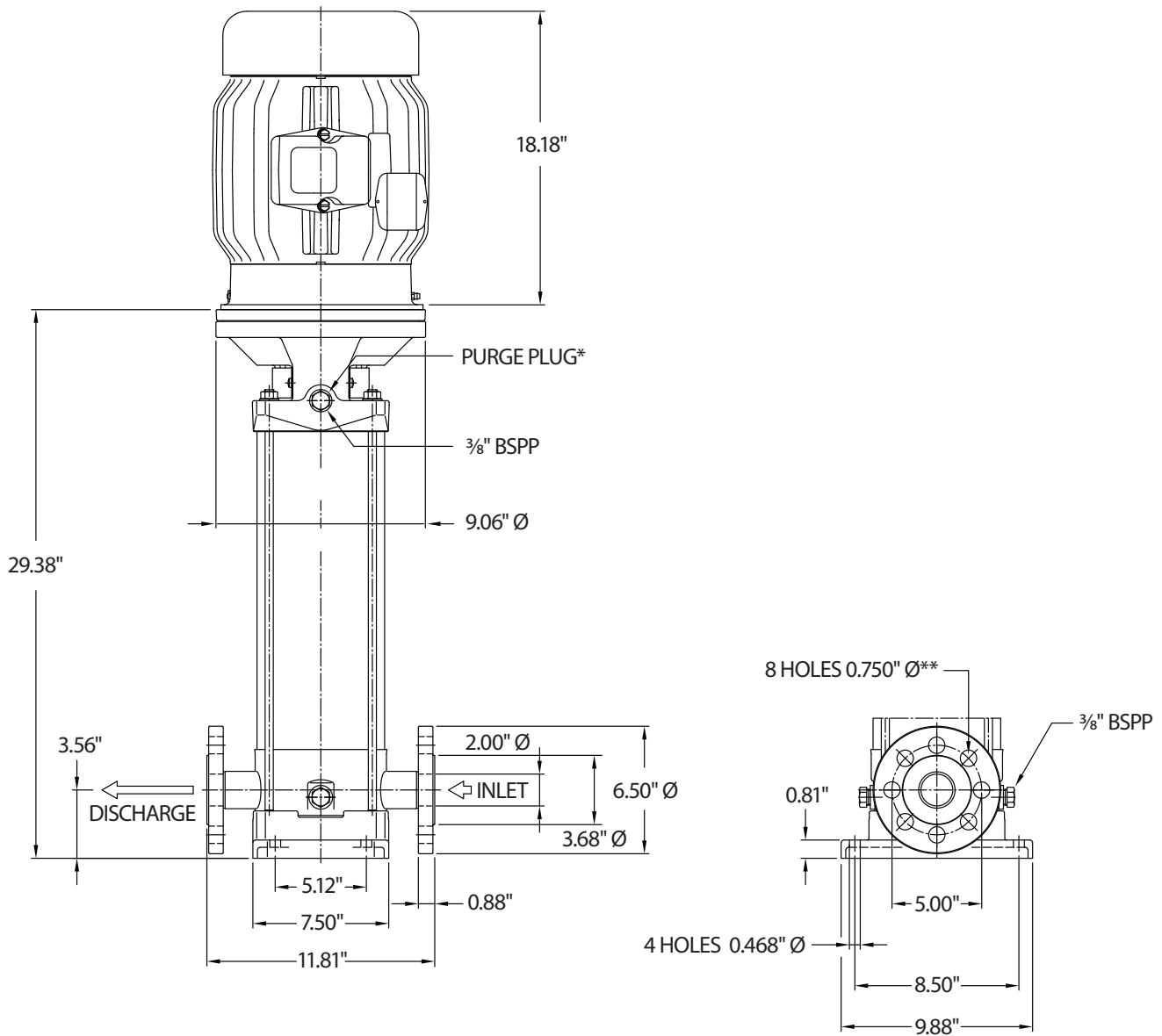

*** All air must be purged out before operation to prevent seal damage.**

**** Flange tightening torque = 26 ft-lbs**

⚠ CAUTIONS AND WARNINGS

All high-pressure systems require a primary pressure regulating device (e.g. regulator, unloader) and a secondary pressure relief device (e.g. pop-off valve, relief valve). Failure to install such relief devices could result in personal injury or damage to pump or property. Cat Pumps does not assume any liability or responsibility for the operation of a customer's high-pressure system.

Read all CAUTIONS and WARNINGS before commencing service or operation of any high-pressure system. The CAUTIONS and WARNINGS are included in each Service Manual and with each Accessory Data sheet. CAUTIONS and WARNINGS can also be viewed online at www.catpumps.com/dynamic-literature/cautions-and-warnings or can be requested directly from Cat Pumps.

WARRANTY

View the Limited Warranty online at www.catpumps.com/literature/cat-pumps-limited-warranty