

DATA SHEET

VERTICAL MULTISTAGE PUMP



**Stainless Steel
Model:**

810K5SF



(Motor Sold Separately)

SPECIFICATIONS

Size

| | |
|-----------|--------------------------|
| Suction | 300# ANSI Raised Face 2" |
| Discharge | 300# ANSI Raised Face 2" |
| HP | 5 hp |
| RPM | 3450 rpm |

Liquid Handled

| | |
|-----------------------|---------------------------|
| Type of Liquid | *Clean Water |
| Temperature Range | -22°–248° F (-30°–120° C) |
| Max. Working Pressure | 230 psi (16 bar) |

Materials

| | |
|---------------------|----------------------------|
| Impeller | AISI 304 |
| Intermediate Casing | AISI 304 |
| Bottom Casing | AISI 304 |
| Casing Cover | AISI 304 |
| Outer Casing | AISI 304 |
| Shaft | AISI 304 |
| Liner Ring | PPS/AISI 304 |
| Motor Bracket | Cast Iron |
| Base | Die Cast Aluminum |
| Lower Pump Bearings | Tungsten Carbide |
| Mechanical Seal | Silicon Carbide/Carbon/FPM |

Motor

| | |
|-----------------------|--------------------------------------|
| Type | NEMA 184TC Frame, TEFC |
| Speed | 60 Hz, 3450 RPM (2 Poles) |
| Single or Three Phase | — |
| Direction of Rotation | Clockwise When Viewed from Motor End |

Weight

| | |
|------|----------|
| Pump | 61.2 lbs |
|------|----------|

*For other clean liquids, consult Cat Pumps.

Note: See PN 99SVM001 for complete operating instructions, installation and maintenance manual information.

PERFORMANCE CURVE – 3450 RPM

79 gpm, 262 Ft/Hd

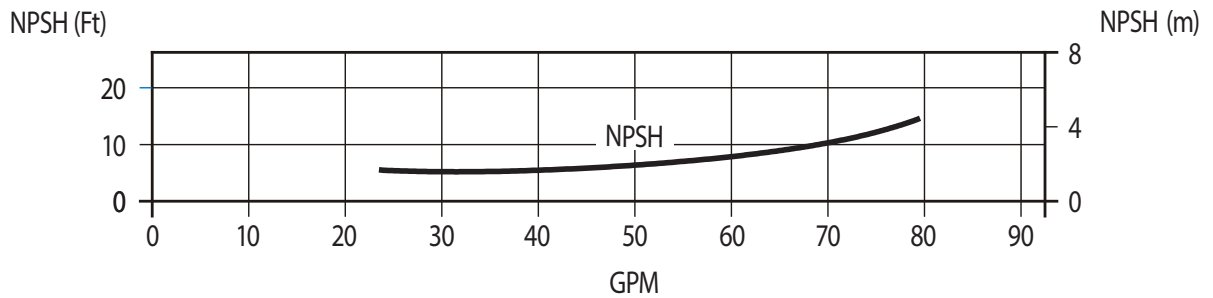
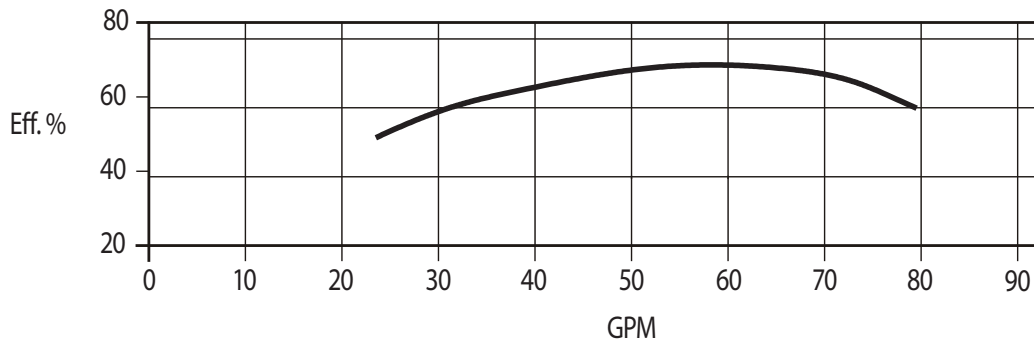
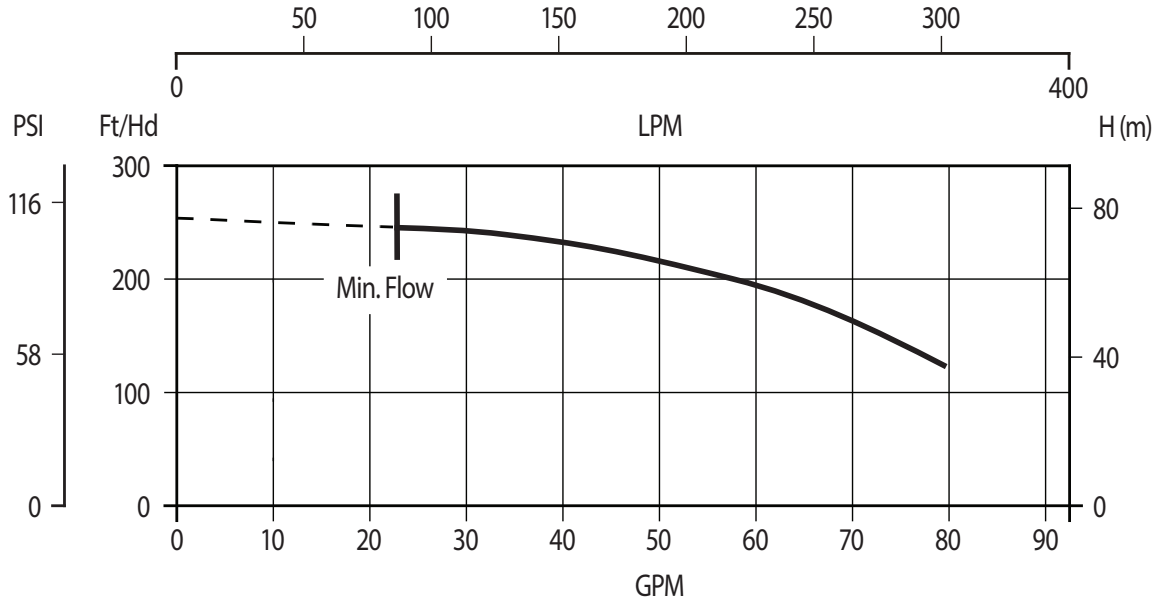

Water Temperature: 68° F (20° C)

EXPLODED VIEW

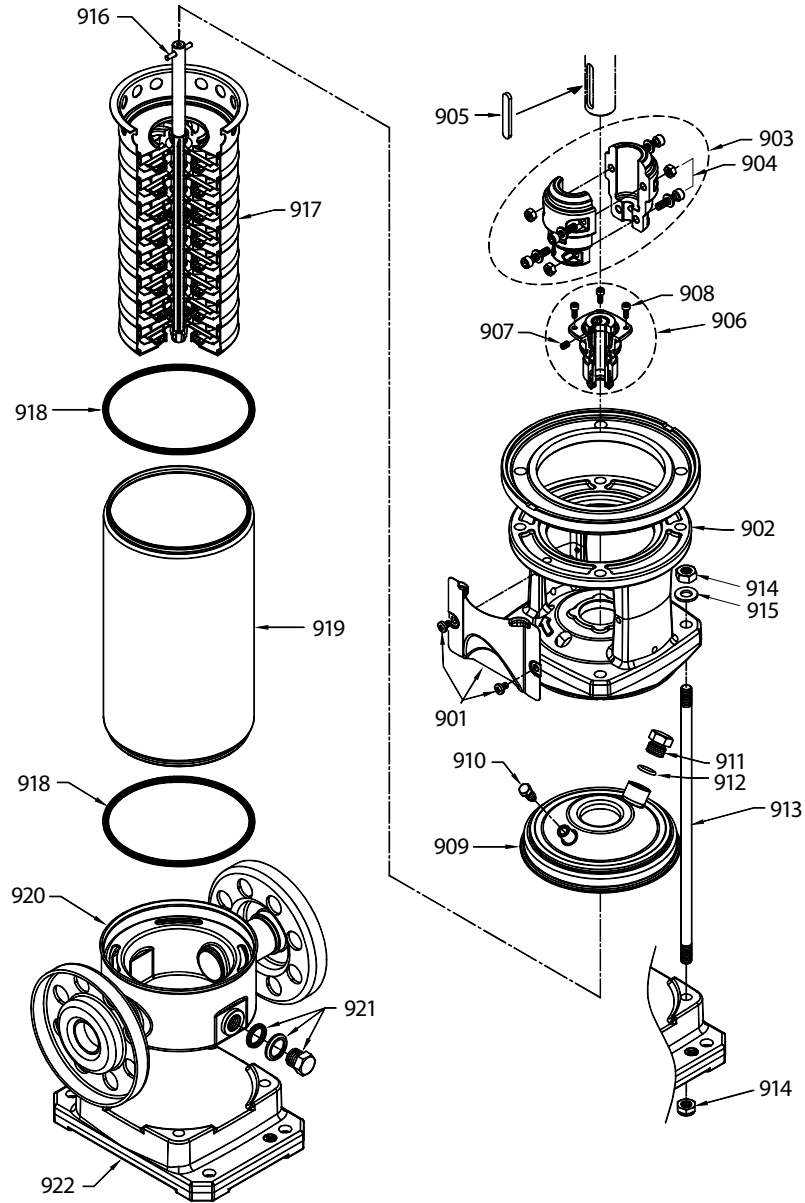

PARTS LIST

| ITEM | P/N | MATL | DESCRIPTION | QTY | ITEM | P/N | MATL | DESCRIPTION | QTY |
|------|-----|------|-----------------------------|-----|------|-----|------|---|-----|
| 901 | — | S | Assembly, Coupler Guard | 2 | 913 | — | STZP | Rod, Tie | 4 |
| 902 | — | F | Bracket, Motor | 1 | 914 | — | STZP | Nut, Tie Rod | 4 |
| 903 | — | AL | Coupling (2-Piece) | 1 | 915 | — | STZP | Washer, Tie Rod | 4 |
| 904 | — | STL | Hardware, Coupling (M6) | 4 | 916 | — | STL | Pin, Shaft | 1 |
| 905 | — | S | Key, Adjuster | 1 | 917 | — | S | Assembly, Hydraulic | 1 |
| 906 | — | FSC | Seal, Mechanical | 1 | 918 | — | FPM | O-Ring, Outer Casing | 2 |
| 907 | — | STL | Screw, Set | 1 | 919 | — | S | Casing, Outer | 1 |
| 908 | — | STZP | Screw, Mechanical Seal Seat | 4 | 920 | — | S | Casing, Bottom | 1 |
| 909 | — | S | Cover, Casing | 1 | 921 | — | S | Assembly, Plug, Drain | 2 |
| 910 | — | S | Plug, Priming | 1 | 922 | — | AL | Base | 1 |
| 911 | — | S | Plug | 1 | 923 | — | — | Kit, Seal (Includes: 906, 918) | 1 |
| 912 | — | FPM | O-Ring, Plug | 1 | 924 | — | — | Kit, Hydraulic (Includes: 905, 906, 917, 918) | 1 |

Italics are optional items

Material Codes (Not part of part number):

AL = Aluminum, F = Cast Iron, FPM = Fluorocarbon, FSC = FPM with Silicon Carbide, S = 304 Stainless Steel, STL = Steel, STZP = Steel/Zinc Plated

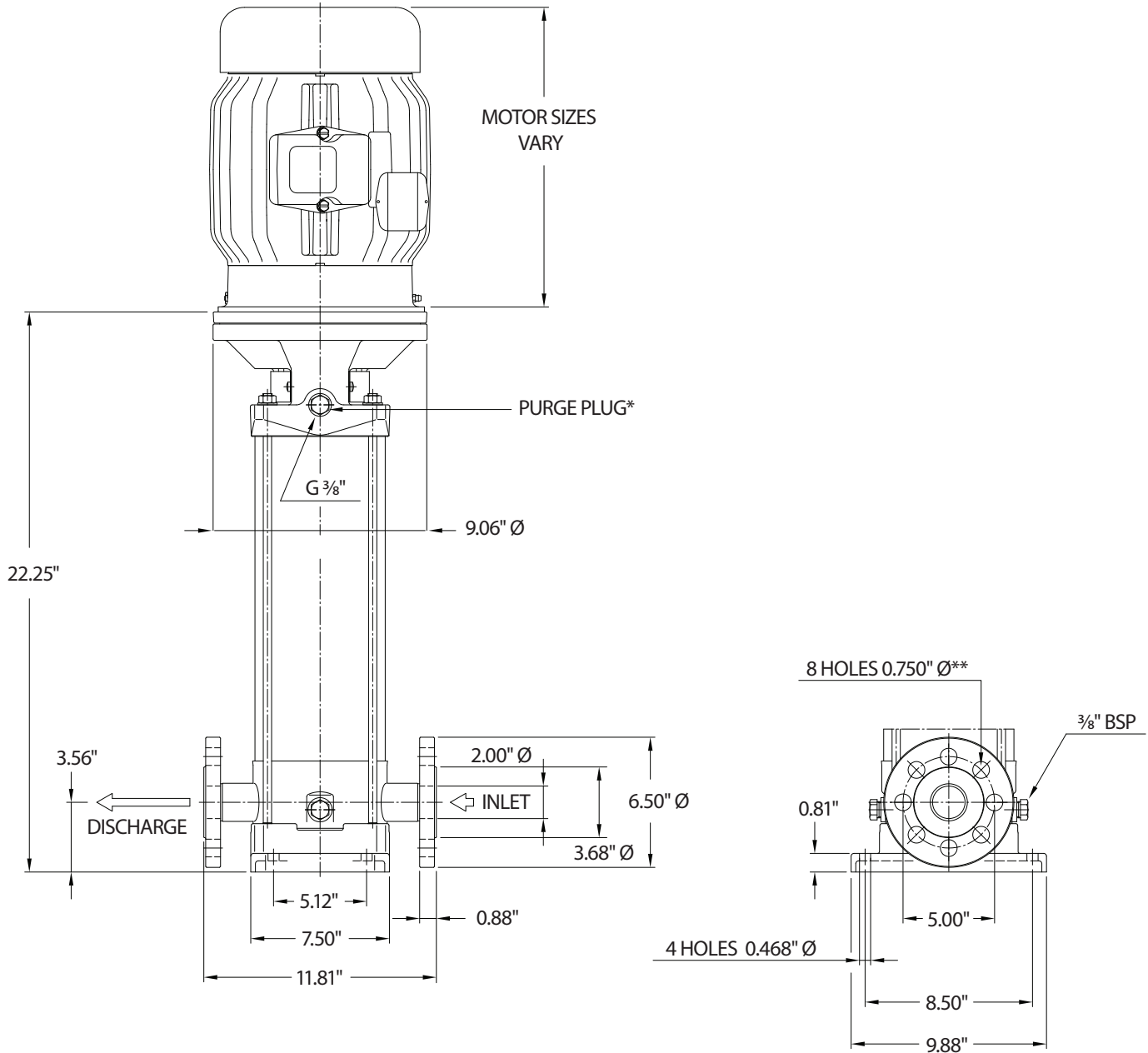

* All air must be purged before operation to prevent seal damage.

** Flange tightening torque = 26 ft-lbs

⚠ CAUTIONS AND WARNINGS

All high-pressure systems require a primary pressure regulating device (e.g. regulator, unloader) and a secondary pressure relief device (e.g. pop-off valve, relief valve). Failure to install such relief devices could result in personal injury or damage to pump or property. Cat Pumps does not assume any liability or responsibility for the operation of a customer's high-pressure system. Read all CAUTIONS and WARNINGS before commencing service or operation of any high-pressure system. The CAUTIONS and WARNINGS are included in each Service Manual and with each Accessory Data sheet. CAUTIONS and WARNINGS can also be viewed online at www.catpumps.com/dynamic-literature/cautions-and-warnings or can be requested directly from Cat Pumps.

WARRANTY

View the Limited Warranty online at www.catpumps.com/literature/cat-pumps-limited-warranty