

DATA SHEET

VERTICAL MULTISTAGE PUMP



Stainless Steel 81K4E1T3F
Model:



SPECIFICATIONS

Size

Suction	300# ANSI raised face 1.25"
Discharge	300# ANSI raised face 1.25"
HP	0.5 hp
RPM	3450 rpm

Liquid Handled

Type of Liquid	*Clean water
Temperature Range	-22°–248° F (-30°–120° C)
Max. Working Pressure	230 psi (16 bar)

Materials

Impeller	AISI 304
Intermediate Casing	AISI 304
Bottom Casing	AISI 304
Casing Cover	AISI 304
Outer Casing	AISI 304
Shaft	AISI 304
Liner Ring	AISI 304
Motor Bracket	Cast Iron
Base	Die Cast Aluminum
Lower Pump Bearings	Tungsten Carbide
Mechanical Seal	Silicon Carbide/Carbon/EPDM

Motor

Type	NEMA 56C Frame, TEFC
Speed	60 Hz, 3450 RPM (2 Poles)
Three Phase	230/460V
Direction of Rotation	Clockwise When Viewed from Motor End

Weight

Pump	27 lbs
Motor	20 lbs

* For other clean liquids, consult Cat Pumps.

NOTE: See PN 99SVM001 for complete operating instructions, installation and maintenance manual information.

PERFORMANCE CURVE – 3450 RPM

12.7 gpm, 108 Head ft.

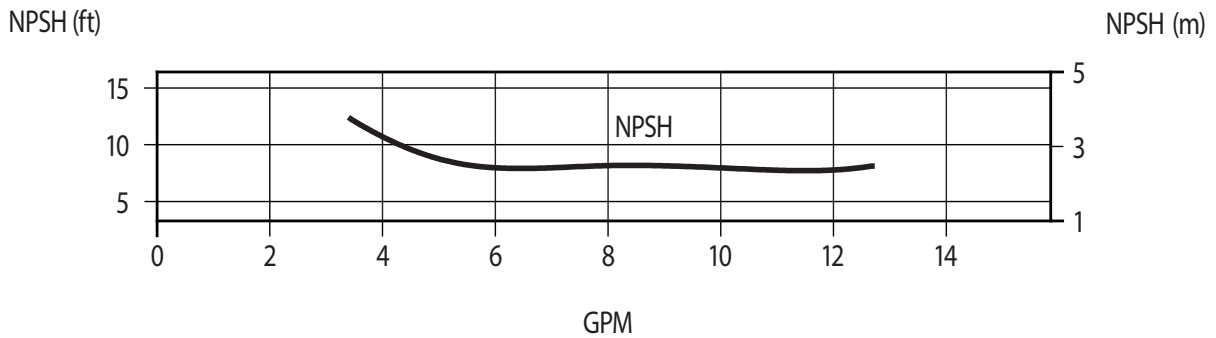
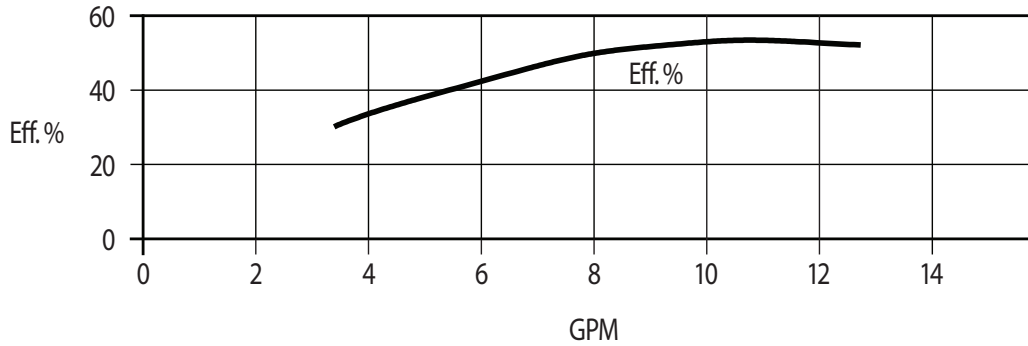
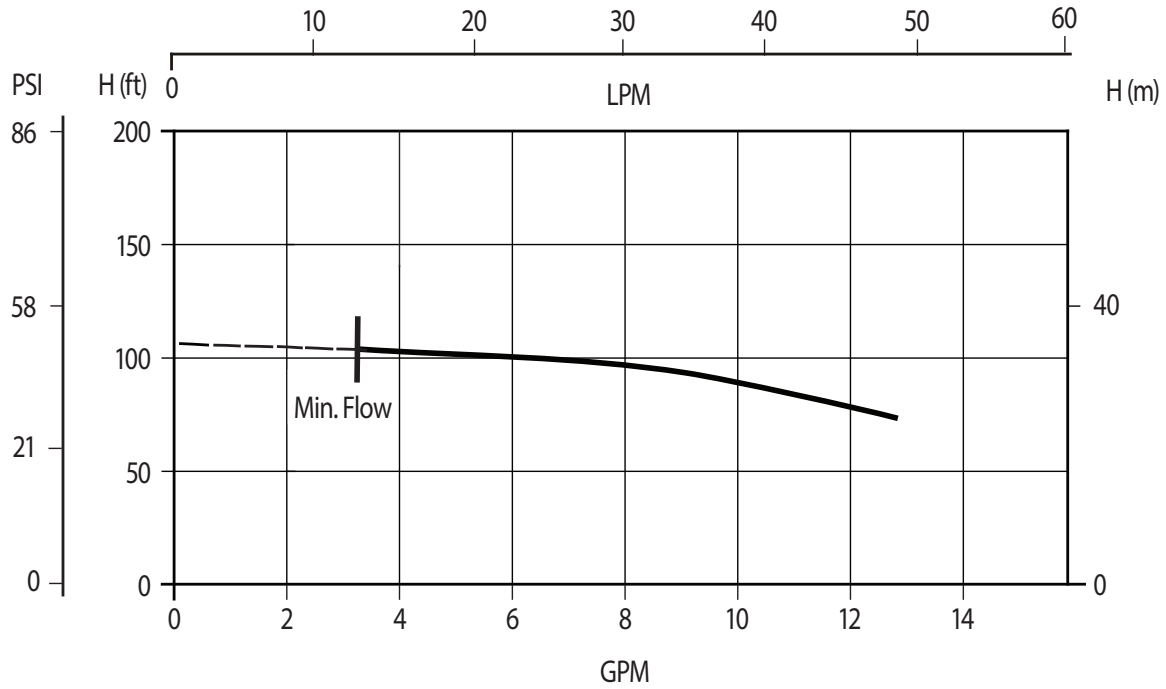

Water Temperature: 68° F (20° C)

EXPLODED VIEW

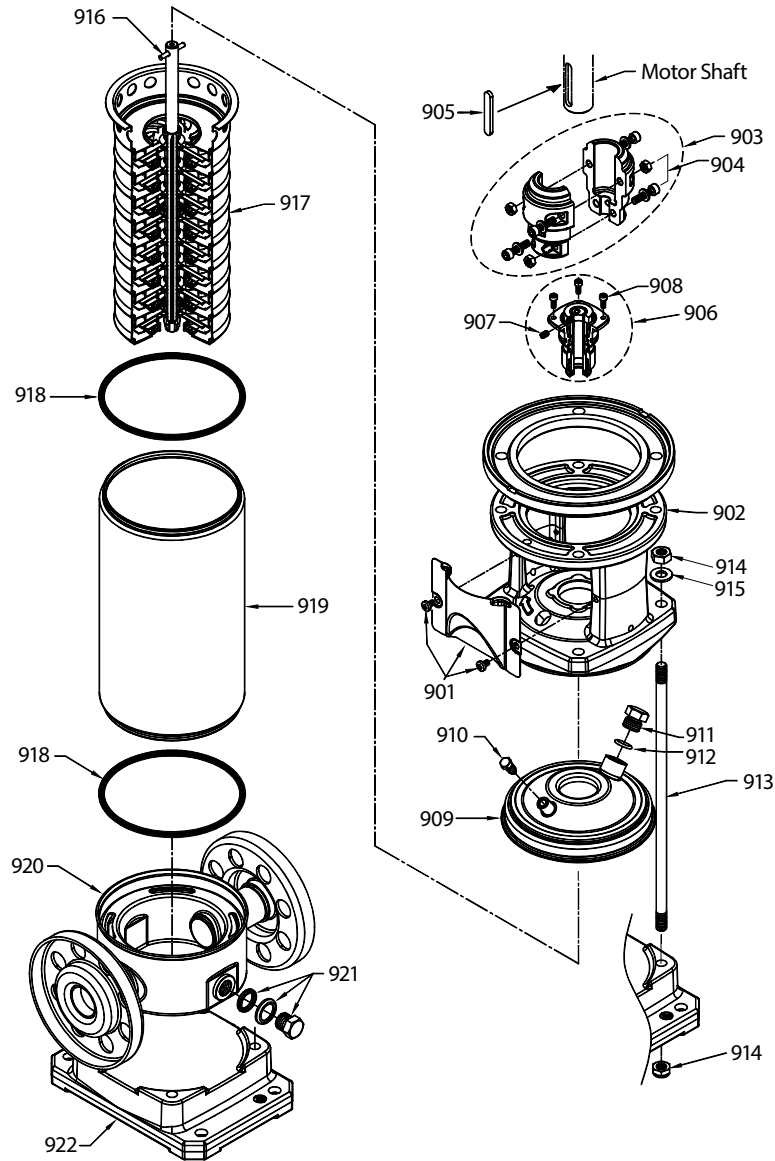

900 Motor Not Shown

PARTS LIST

ITEM	P/N	MATL DESCRIPTION	QTY	ITEM	P/N	MATL DESCRIPTION	QTY
900	—	Motor, Electric (Not Shown)	1	913	—	STZP Rod, Tie	4
901	—	S Assembly, Coupler Guard	2	914	—	STZP Nut, Tie Rod	4
902	—	F Bracket, Motor	1	915	—	STZP Washer, Tie Rod	4
903	—	AL Coupling (2-Piece)	1	916	—	STL Pin, Shaft	1
904	—	STL Hardware, Coupling (M6)	4	917	—	S Assembly, Hydraulic	1
905	—	S Key, Adjuster	1	918	—	EPDM O-Ring, Outer Casing	2
906	—	ESC Seal, Mechanical	1	919	—	S Casing, Outer	1
907	—	STL Screw, Set	1	920	—	S Casing, Bottom	1
908	—	STZP Screw, Mechanical Seal Seat	4	921	—	S Assembly, Plug, Drain	2
909	—	S Cover, Casing	1	922	—	AL Base	1
910	—	S Plug, Priming	1	923	—	— Kit, Seal (Includes: 906, 918)	1
911	—	S Plug	1	924	—	— Kit, Hydraulic (Includes: 905, 906, 917, 918)	1
912	—	EPDM O-Ring, Plug	1				

Note: Contact Cat Pumps for part numbers for seals or hydraulic kits.

Italics are optional items

Material Codes (Not part of part number):

AL= Aluminum EPDM= Ethylene Propylene Diene Monomer F= Cast Iron
 ESC= Silicon Carbide/Carbon/EPDM S= 304 Stainless Steel STL= Steel STZP= Steel/Zinc Plated

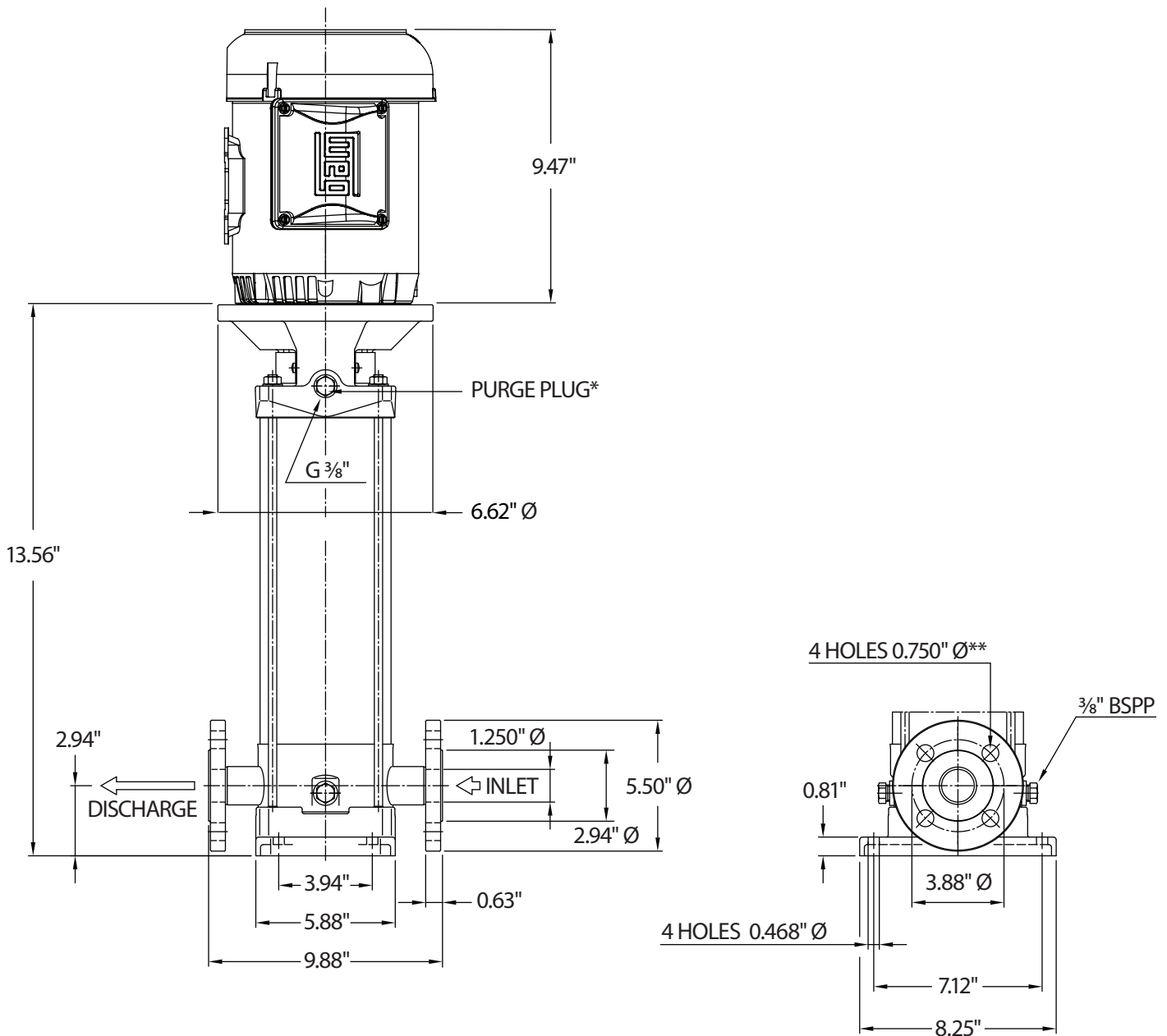

* All air must be purged out before operation to prevent seal damage.

** Flange tightening torque = 52 ft-lbs.

⚠ CAUTIONS AND WARNINGS

All high-pressure systems require a primary pressure regulating device (e.g. regulator, unloader) and a secondary pressure relief device (e.g. pop-off valve, relief valve). Failure to install such relief devices could result in personal injury or damage to pump or property. Cat Pumps does not assume any liability or responsibility for the operation of a customer's high-pressure system. Read all CAUTIONS and WARNINGS before commencing service or operation of any high-pressure system. The CAUTIONS and WARNINGS are included in each Service Manual and with each Accessory Data sheet. CAUTIONS and WARNINGS can also be viewed online at www.catpumps.com/dynamic-literature/cautions-and-warnings or can be requested directly from Cat Pumps.

WARRANTY

View the Limited Warranty online at www.catpumps.com/literature/cat-pumps-limited-warranty