

# DATA SHEET

## VERTICAL MULTISTAGE PUMP



**Stainless Steel  
Model:**

**832K22S8T3F**



### SPECIFICATIONS

#### Size

Suction	150# ANSI Raised Face 2"
Discharge	150# ANSI Raised Face 2"
HP	7.5 hp
RPM	3450 rpm

#### Liquid Handled

Type of Liquid	**Clean Water
Temperature Range	-22°–248° F (-30°–120° C)
Max. Working Pressure	230 psi (16 bar)

#### Materials

Impeller	AISI 304
Intermediate Casing	AISI 304
Bottom Casing	Cast Iron
Casing Cover	Cast Iron
Outer Casing	AISI 304
Shaft	AISI 316
Liner Ring	PTFE/AISI 316
Motor Bracket	Cast Iron
Base	Cast Iron
Pump Bearing	Tungsten Carbide
Mechanical Seal	Silicon Carbide/Carbon/FPM

#### Motor

Type	NEMA 184TC Frame
Speed	60 Hz, 3450 RPM (2 Poles)
Three Phase	*230/460V
Direction of Rotation	Clockwise When Viewed from Motor End
Test Standard	ISO 9906 Annex A

#### Weight

Pump	126 lbs
Motor	88 lbs

\* Prior to Department of Energy (DOE) EERE-2020-BT-TP-0011 motor was name-plated rated 208–230 Volt.

\*\* For other clean liquids, consult Cat Pumps.

**Note: See PN 99SVM001 for complete operating instructions, installation and maintenance manual information.**

# PERFORMANCE CURVE – 3450 RPM

185 gpm, 170 Ft/Hd

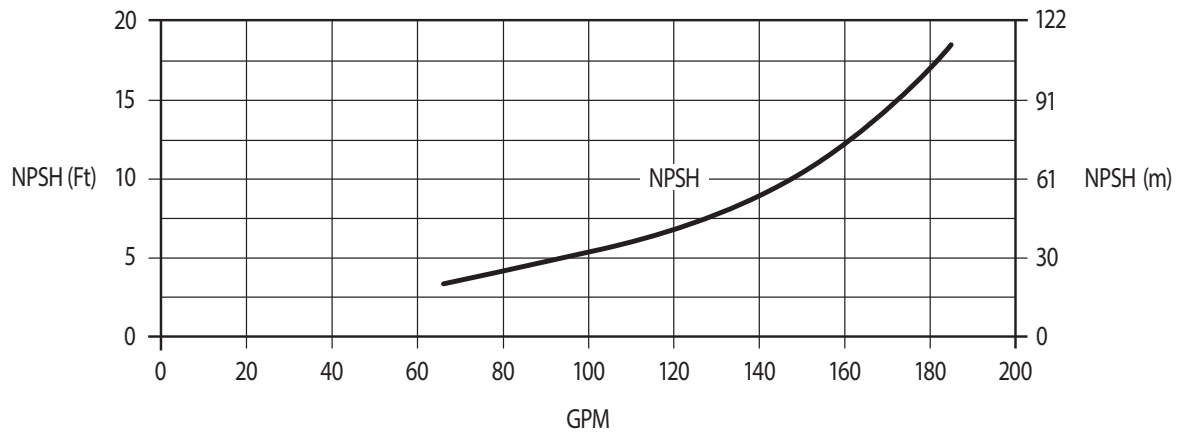
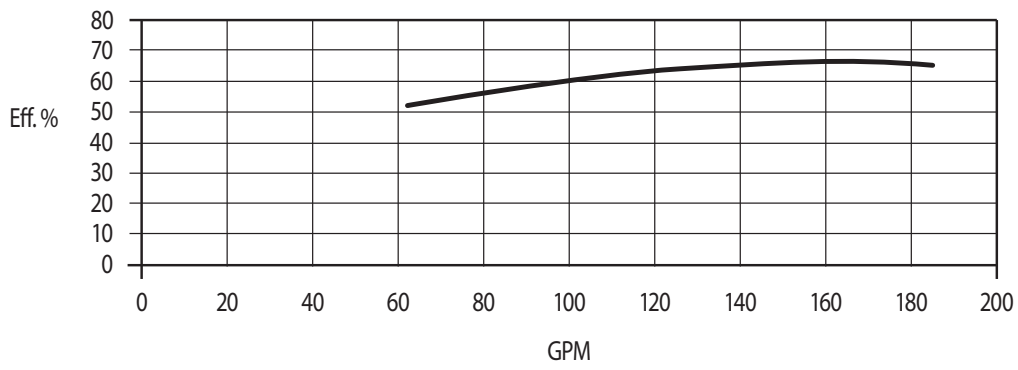
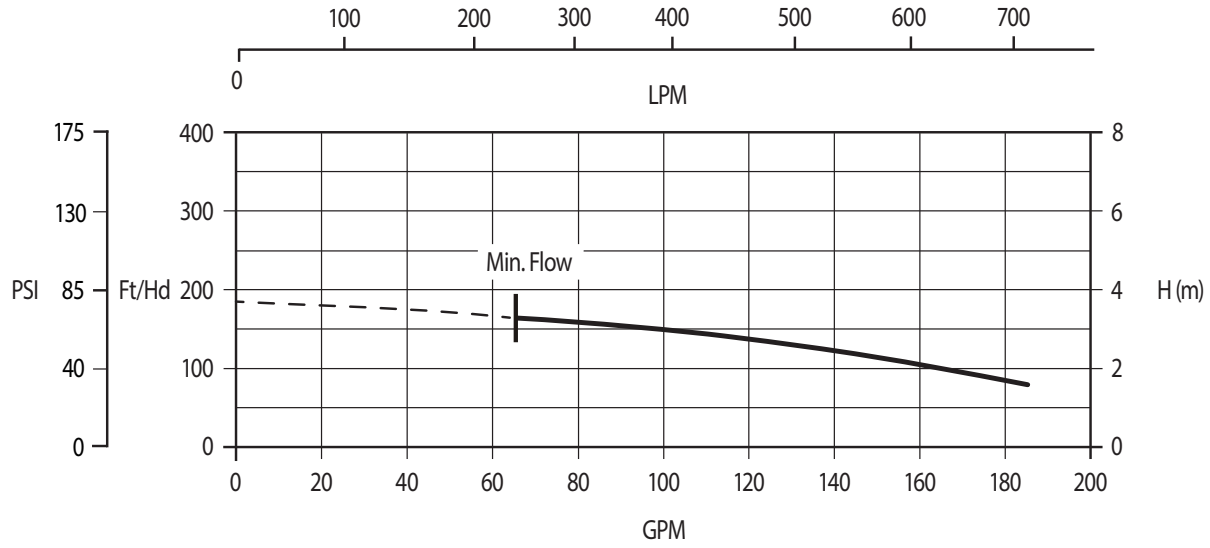

Water Temperature: 68° F (20° C)

# EXPLODED VIEW

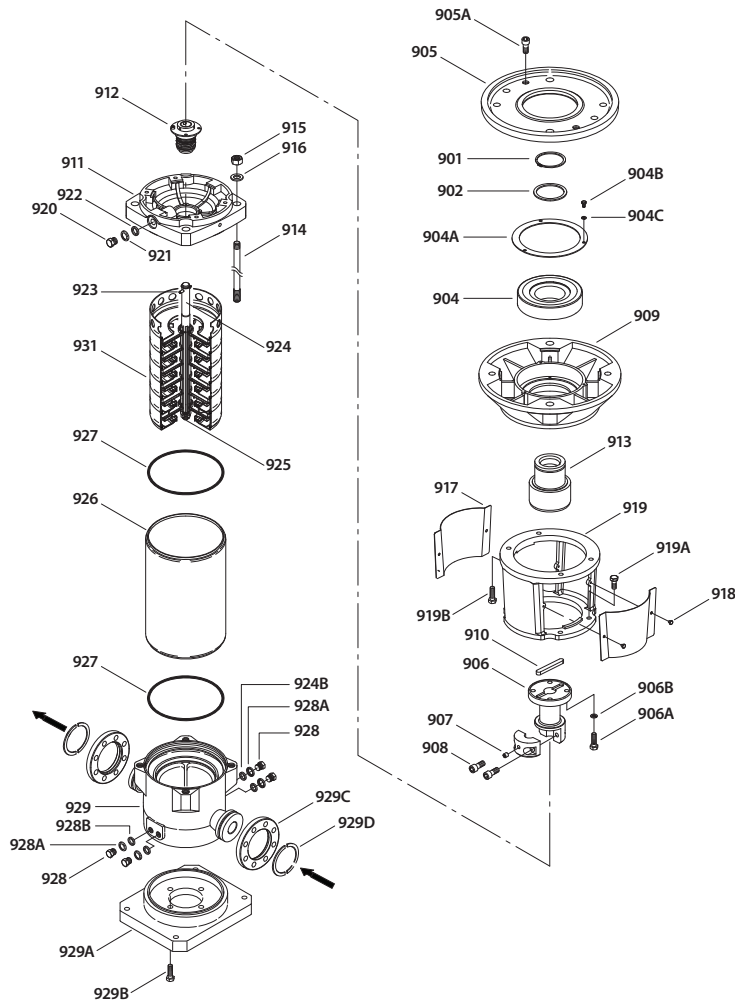

900 Motor Not Shown

## PARTS LIST

ITEM	P/N	MATL	DESCRIPTION	QTY	ITEM	P/N	MATL	DESCRIPTION	QTY
900	—	—	Motor, Electric (Not Shown)	1	919B	—	STZP	Screw, Bearing Housing	4
901	—	STL	Ring, Snap, C-Type for Coupler	1	920	—	SS	Plug, Vent	1
902	—	STL	Spacer	1	921	—	S	Washer, Vent Plug	1
904	—	STL	Bearing, Ball	1	922	—	FPM	O-Ring, Vent Plug	1
904A	—	S	Holder, Bearing	1	923	—	STL	Pin, Shaft	1
904B	—	STZP	Screw, Bearing Holder	3	924	—	SS	Shaft	1
904C	—	STZP	Washer, Spring, Bearing Holder	3	925	—	S	Nut, Impeller	1
905	—	F	Liner, Motor	1	926	—	SS	Casting, Outer	1
905A	—	STZP	Screw, Motor Liner	4	927	—	FPM	O-Ring, Outer Casing	2
906	—	STL	Coupling, Lower	1	928	—	SS	Plug, Drain	4
906A	—	STZP	Screw, Lower Coupling	4	928A	—	SS	Washer, Drain Plug	4
906B	—	STZP	Washer, Spring, Lower Coupling	4	928B	—	FPM	O-Ring, Drain Plug	4
907	—	STL	Screw, Set	1	929	—	SS	Casing, Bottom	1
908	—	STZP	Screw, Coupler	2	929A	—	F	Base	1
909	—	F	Housing, Bearing	1	929B	—	STZP	Screw, Base	4
910	—	STL	Key	1	929C	—	STL	Flange, Pump	2
911	—	F+S	Cover, Casing	1	929D	—	STL	Ring, Adjusting	2
912	—	FSC	Seal, Mechanical	1	930	899409		Kit, Seal (Includes: Mechanical Seal and Two (2) Outer Casing O-Rings)	1
913	—	STL	Coupling, Upper	1	931	—		Kit, Hydraulic Includes: Hydraulic Assembly Upper and Lower Casing O-Rings Pump Shaft Key Pumps Coupling Snap Ring Mechanical Seal with O-Rings	1
914	—	STZP	Rod, Tie	4					
915	—	STZP	Nut, Tie Rod	4					
916	—	STZP	Washer, Tie Rod	4					
917	—	S	Guard, Coupling	2					
918	—	S	Screw, Coupling Guard	2					
919	—	F	Bracket, Motor	1					
919A	—	S	Screw, Motor Bracket	4					

Italics are optional items

Material Codes (Not part of part number): F= Cast Iron FPM= Fluorocarbon FSC= FPM with Silicon Carbide S= 304 Stainless Steel SS= 316 Stainless Steel STL= Steel STZP= Steel/Zinc Plated

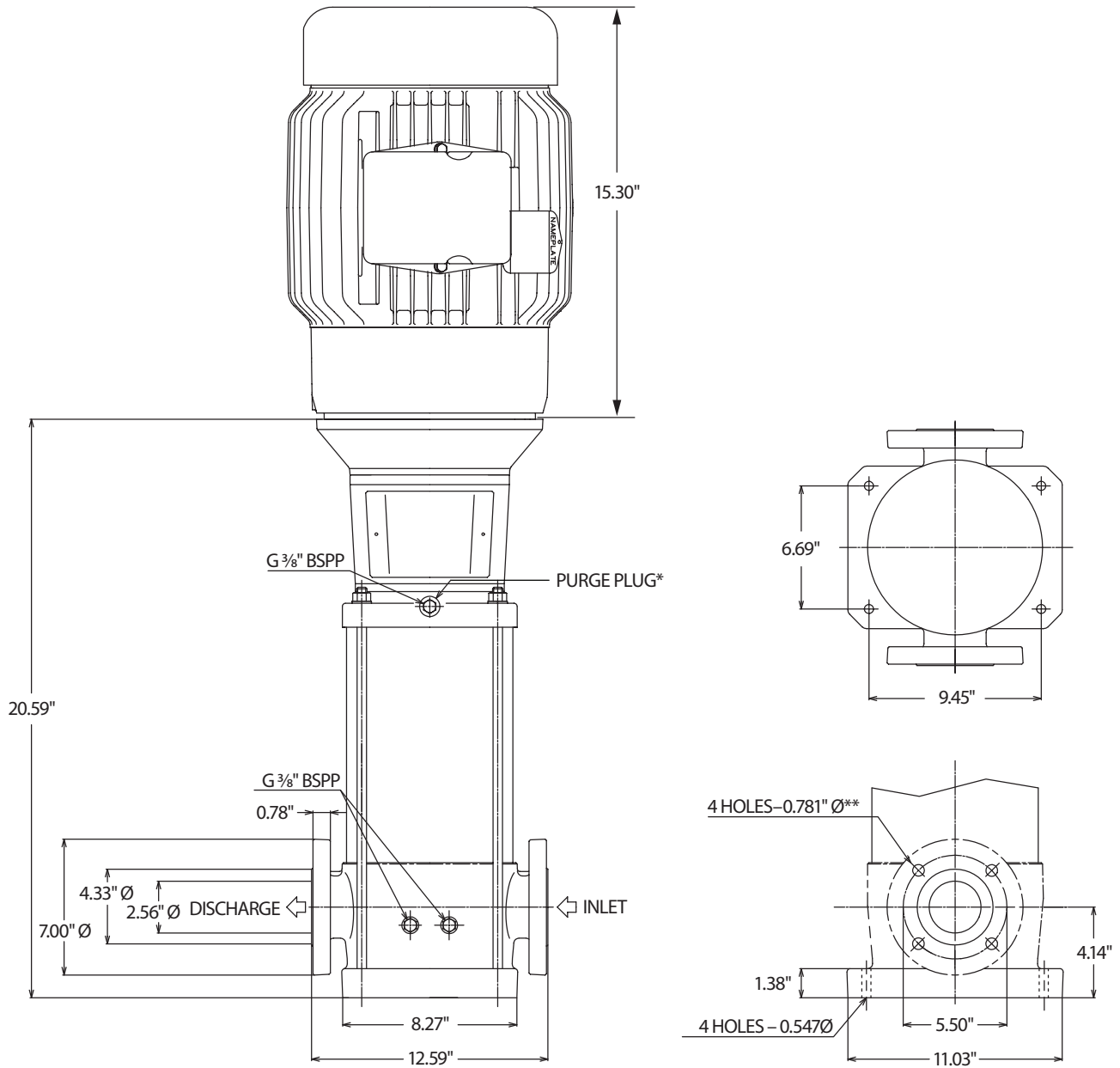

**\* All air must be purged out before operation to prevent seal damage.**

**\*\* Flange tightening torque = 59 ft-lbs**

**⚠ CAUTIONS AND WARNINGS**

All high-pressure systems require a primary pressure regulating device (e.g. regulator, unloader) and a secondary pressure relief device (e.g. pop-off valve, relief valve). Failure to install such relief devices could result in personal injury or damage to pump or property. Cat Pumps does not assume any liability or responsibility for the operation of a customer's high-pressure system.

Read all CAUTIONS and WARNINGS before commencing service or operation of any high-pressure system. The CAUTIONS and WARNINGS are included in each Service Manual and with each Accessory Data sheet. CAUTIONS and WARNINGS can also be viewed online at [www.catpumps.com/dynamic-literature/cautions-and-warnings](http://www.catpumps.com/dynamic-literature/cautions-and-warnings) or can be requested directly from Cat Pumps.

**WARRANTY**

View the Limited Warranty online at [www.catpumps.com/literature/cat-pumps-limited-warranty](http://www.catpumps.com/literature/cat-pumps-limited-warranty)