

DATA SHEET

DIRECT DRIVE PLUNGER PUMP



Brass Model: 67DX39G11



FEATURES

- Triplex plunger design ensures high efficiency and low pulsation.
- Compact flange mount permits easy, direct mounting to most gas engines.*
- Integral regulating unloader with built-in bypass ensures system pressure control and pump protection.
- Stacked stainless steel valve design promotes long life and easy servicing.
- Fixed chemical injector aids in cleaning flexibility.
- Includes crankcase oil.
- Pump comes standard with NBR seals. Alternative seal materials are available for higher temperature or chemical compatibility.

*Gas Mounting Flange: SAE J609, Flange B, Extension 4 (1"Ø), Shaft Length= 3¼", Pilot Ø= 5¾", B.C. Ø= 6½", Thread ¾"-16 UNC TAP.

SPECIFICATIONS	U.S. Measure	Metric Measure
Flow	3.9 gpm	14.8 lpm
Pressure Range	100–4000 psi	6.9–275 bar
Pump RPM	3450 rpm	3450 rpm
Inlet Pressure Range	Flooded to 75 psi	Flooded to 5.2 bar
Max. Liquid Temperature	140° F	60° C
Bore	0.551"	14 mm
Stroke	0.405"	10.3 mm
Crankcase Capacity	13.5 oz	0.4 l
Inlet Port (1)	½" NPT(F)	½" NPT(F)
Discharge Port (1)	¾" NPT(F)	¾" NPT(F)
Discharge Port With Chemical Injector (1)	¾" NPT(M)	¾" NPT(M)
Inlet Auxiliary Port (1)	¼" NPT(F)	¼" NPT(F)
Shaft Diameter (Hollow)	1"	25.4 mm
Weight	17 lbs	7.7 kg
Dimensions	11.50 x 8.82 x 7.99"	292 x 224 x 203 mm

TORQUE AND HORSEPOWER REQUIREMENTS

	FLOW		PRESSURE						PUMP RPM
	GPM	LPM	2500		3200		4000		
			PSI	BAR	PSI	BAR	PSI	BAR	
Torque	3.9	14.8	10.2 ft-lbs		13.0 ft-lbs		16.3 ft-lbs		3450
Horsepower*			8.6 hp		10.9 hp		13.7 hp		

*HP is for estimate only. Torque values of the engine at given rpm should be used to determine correct size of engine.

Consult engine manufacturer for actual torque available at required speed.

DETERMINING THE PROPER TORQUE

$$\text{Torque (ft-lbs)} = 3.6 \times \frac{\text{gpm} \times \text{psi}}{\text{rpm}}$$

DETERMINING THE REQUIRED HP

$$\text{Engine hp (Estimated)} = \frac{\text{gpm} \times \text{psi}}{1140}$$

DETERMINING THE PUMP RPM

$$\frac{\text{Rated gpm}}{\text{Rated rpm}} = \frac{\text{Desired gpm}}{\text{Desired rpm}}$$

Refer to pump **Service Manual** for repair procedure and additional technical information.

EXPLODED VIEW

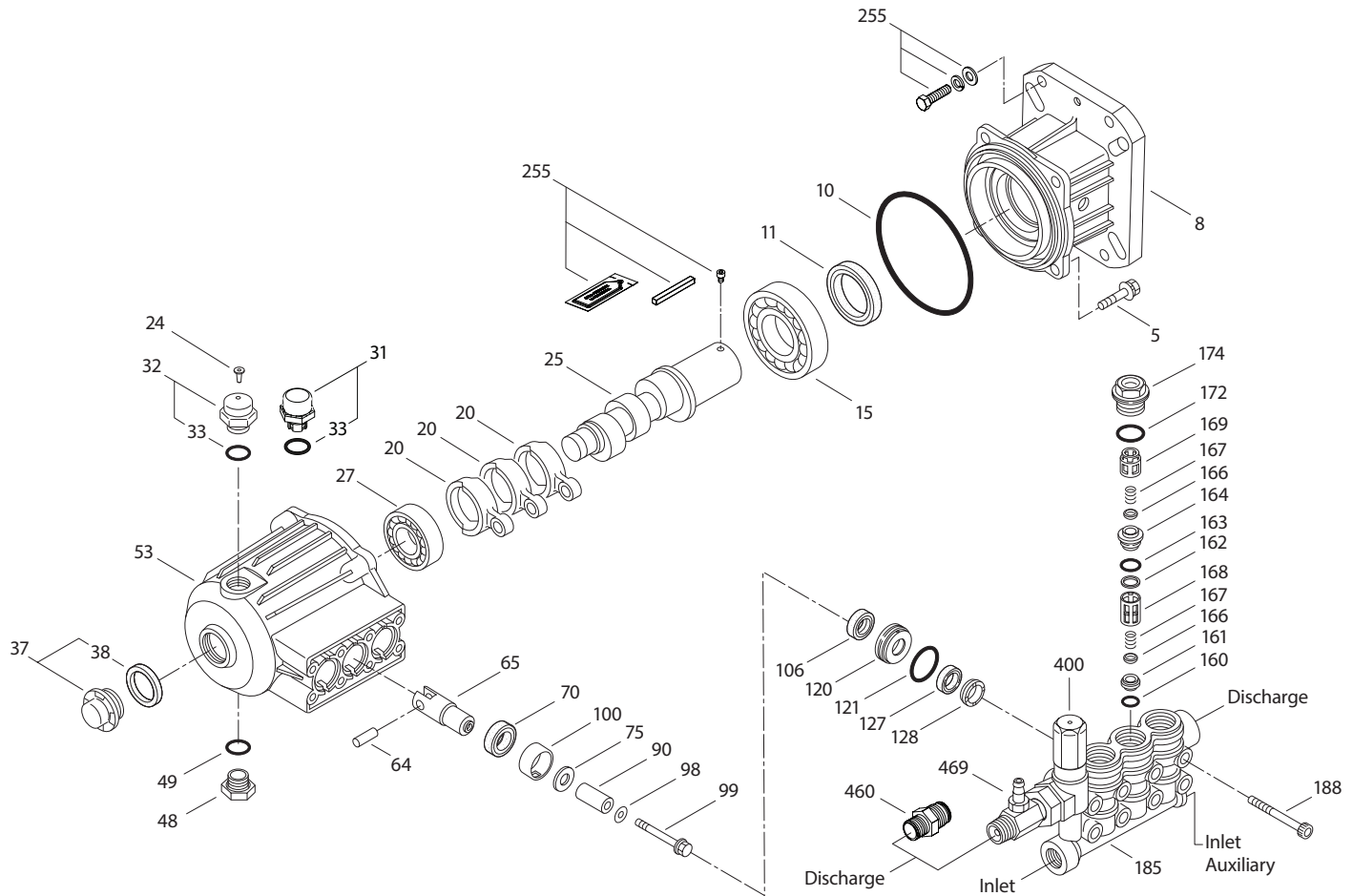

PARTS LIST

ITEM	P/N	MATL	DESCRIPTION	QTY
5	127285	STCP R	Screw, HH, Sems (M8 x 25) (See Tech Bulletin 074)	4
8	49361	AL	Cover, Adapter Bearing	1
10	14043	NBR	O-Ring, Bearing Cover	1
11	125351	NBR	Seal, Oil Crankshaft	1
15	146421	STL	Bearing, Ball - Inner	1
20	49364	TNM	Rod, Connecting	3
24	549608	LDPE	Plug, Oil Cap	1
25	49391	CM	Crankshaft (M10.3)	1
27	49363	STL	Bearing, Ball - Outer	1
31	549726	—	Cap, Vented with O-Ring (Rain Cap)	1
32	547961	RTP	Cap, Oil Filler with O-Ring	1
33	14179	NBR	O-Ring, Filler Cap-70D	1
37	92241	PC	Gauge, Oil Bubble with Gasket-80D (See Tech Bulletin 074)	1
38	44428	NBR	Gasket, Flat, Oil Gauge-80D	1
48	44842	NY	Plug, Drain	1
49	14179	NBR	O-Ring, Drain Plug-70D	1
53	49352	AL	Crankcase	1
64	49366	CM	Pin, Crosshead	3
65	49368	BB	Rod, Plunger	3
70	47215	NBR	Seal, Oil Crankcase	3
75	49370	S	Slinger, Barrier	3
90	49367	CC	Plunger (M14 x 28)	3
98	46730	NBR	Washer, Seal-90D	3
99	49369	S	Retainer, Plunger (See Tech Bulletin 074)	3
100	49371	NY	Retainer, Seal	3

ITEM	P/N	MATL	DESCRIPTION	QTY
106	45188	NBR	Seal, Low-Pressure with S-Spring	3
120	49374	BB	Case, Seal	3
121	13977	NBR	O-Ring, Seal Case-70D	3
127	49606	PTFE	V-Packing (Black)	3
128	49605	D	Adapter, Male	3
160	26129	NBR	O-Ring, Inlet Valve Seat-70D	3
161	49378	S	Seat, Inlet	3
162	48361	D	Backup Ring, Discharge Seat	3
163	43358	NBR	O-Ring, Discharge Seat-70D	3
164	49376	S	Seat, Discharge	3
166	547098	S	Valve	6
167	49354	S	Spring	6
168	49377	PVDF	Retainer, Spring, Inlet	3
169	547441	PVDF	Retainer, Spring, Discharge	3
172	49382	NBR	O-Ring, Valve Plug-90D	3
174	49380	BB	Plug, Valve (See Tech Bulletin 074)	3
185	49372	BB	Head, Manifold	1
188	126512	STCP R	Screw, HSH (M8 x 65) (See Tech Bulletin 074)	8
197	941517	BB	Assembly, GH (1/2" NPT[M] x 3/4" GH[F]) (Not Shown)	1
255	31445	STZP	Assembly, Bolt Mount, Gas	1
300	76262	NBR	Kit, Seal (Includes: 98, 106, 121, 127, 128)	1
310	76260	NBR	Kit, Valve Pre-Assembled (Includes: 160-164, 166, 167, 168, 169, 172)	1
400	—	—	Unloader, Integral (See Individual Parts)	1
460	126974	BB	Fitting, Discharge (3/8" NPT[M])	1
469	7367	BB	Injector, Chemical Fixed	1

Italics are optional items. R Components comply with RoHS Directive. For additional technical information see www.catpumps.com/literature/tech-bulletins
MATERIAL CODES (Not Part of Part Number): AL=Aluminum BB=Brass CC=Ceramic CM=Chrome-moly D=Acetal LDPE=Low Density Polyethylene
 NBR=Medium Nitrile (Buna-N) NY=Nylon PC=Poly Carbonate PTFE=Pure Polytetrafluoroethylene PVDF=Polyvinylidene Fluoride
 RTP=Reinforced Composite S=304SS STCP=Steel/Chrome Plated STL=Steel STZP=Steel/Zinc Plated TNM=Special High Strength

INTEGRAL UNLOADER

SPECIFICATIONS

	U.S.	Metric
Flow	3.9 gpm	14.8 lpm
PSI Range	100–4000 psi	6.9–275 bar
Inlet Port	½" NPT(F)	½" NPT(F)
Discharge Port With Chemical Injector	¾" NPT(M)	¾" NPT(M)

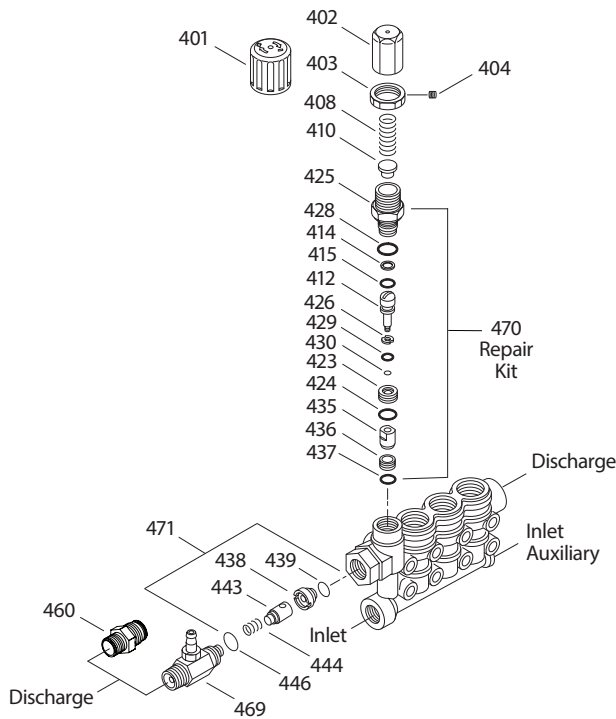

PARTS LIST

ITEM	P/N	MATL	DESCRIPTION	QTY
401	49100	NY	Handle, Adjusting (Black)	1
402	49099	BB	Cap, Adjusting	1
403	125521	BB	Nut, Locking (M25 x 1)	1
404	88953	S	Screw, Set (M4 x 4)	1
408	45198	ZP R	Spring, Pressure	1
410	49101	STZP R	Retainer, Spring	1
412	49103	S	Stem, Piston	1
414	129638	PTFE	Backup Ring, Piston Stem	1
415	49104	NBR	O-Ring, Piston Stem–90D	1
423	49105	BB	Retainer, Valve	1
424	49106	NBR	O-Ring, Valve Retainer–70D	1
425	49102	BB	Retainer, Piston	1
426	49107	S	Washer	1
428	26133	NBR	O-Ring, Piston Retainer–80D	1
429	22056	NBR	O-Ring, Valve Retainer–70D	1
430	49123	D	Backup Ring, Valve Retainer	1
435	49383	S	Valve/Ball Assembly	1
436	49384	S	Seat	1
437	13965	NBR	O-Ring, Seat–70D	1
438	49386	D	Seat, Check Valve	1
439	13963	NBR	O-Ring, Check Valve Seat–70D	1
443	49245	BB	Valve, Check with NBR O-Ring	1
444	117275	S	Spring, Check Valve	1
446	26133	NBR	O-Ring, Body–80D	1
460	126974	BB	Fitting, Discharge (¾" NPT[M])	1
468	76708	NBR	Kit, O-Ring (Includes: 414, 415, 424, 428, 429, 430, 437, 439, 446)	1
469	7367	BB	Injector, Chemical Fixed	1
470	31556	NBR	Kit, Repair (Includes: 412, 414, 415, 423–426, 428–430, 435–437)	1
471	76188	NBR	Kit, Check Valve (Includes: 438–446)	1

Italics are optional items. R Components comply with RoHS Directive.

MATERIAL CODES (Not Part of Part Number): BB=Brass D=Acetal NBR=Medium Nitrile (Buna-N) NY=Nylon PTFE=Pure Polytetrafluoroethylene S=304SS STZP=Steel/Zinc Plated ZP=Zinc Plated

MODEL 7367 FIXED CHEMICAL INJECTOR

SPECIFICATIONS

	U.S.	Metric
Flow	3.9 gpm	14.8 lpm
Nozzle Orifice	2.1 mm	2.1 mm
Hose Barb	¼"	¼"
Inlet Port	M20 x 1.0	M20 x 1.0
Discharge Port	¾" NPT(M)	¾" NPT(M)
Weight	0.25 lbs	0.11 kg
Dimensions	1.75 x 1.0 x 1.12"	44 x 25.4 x 54 mm

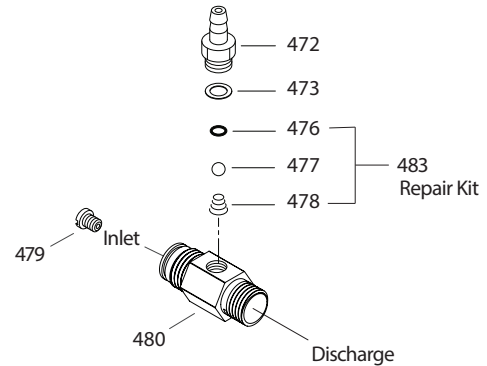

PARTS LIST

ITEM	PN	MATL	DESCRIPTION	QTY
472	49132	BB	Barb, Fix	1
473	—	—	Gasket	1
476	—	NBR	O-Ring, Barb–70D	1
477	—	S	Ball	1
478	—	S	Spring	1
479	—	S	Orifice	1
480	—	BB	Body	1
483	76176	NBR	Kit, Repair (Includes: 476, 477, 478)	1

MATERIAL CODES (Not Part of Part Number):
BB=Brass NBR=Medium Nitrile (Buna-N) S=304SS

PERFORMANCE CHART

Orifice Size	Maximum Injecting Pressure	Maximum Chemical Draw	Pressure Drop Across Orifice
2.1 mm	358 psi	76.8 oz/min	288 psi

Note: Optimum performance of Chemical Injector occurs with a 35 ft high-pressure hose with a minimum ¾" ID. The type of hose, extended lengths, reduced ID and fittings may create additional backpressure above the maximum injecting pressure rating of the injector and prevent it from drawing chemicals.

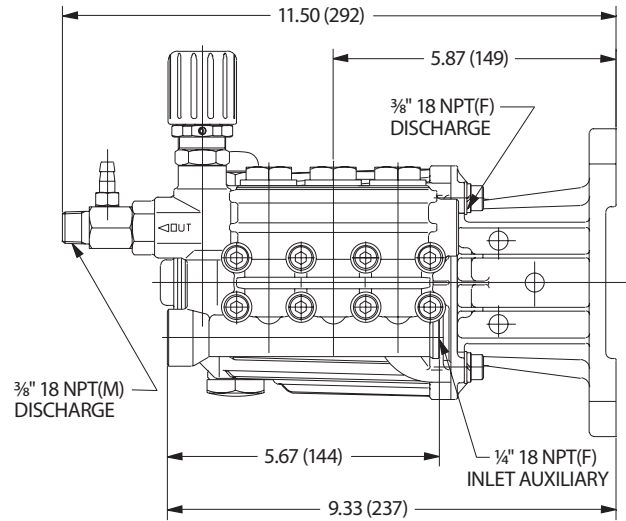
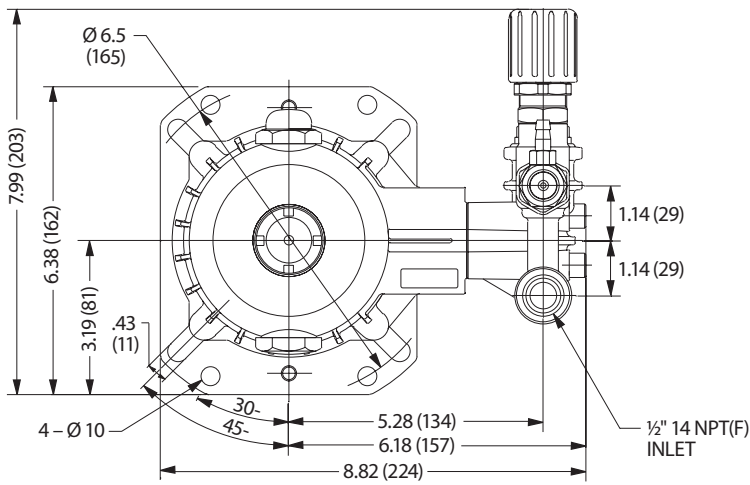

UNLOADER TYPE:

An integral unloader with built-in bypass is part of the discharge manifold to provide system pressure regulation and pump protection. This pump also includes a fixed chemical injector for chemical application.

OPERATION:

Pump should be purged of air before commencing with operation. Liquid must flow through the pump without discharge restriction to ensure full system pressure is reached.

Install a pressure gauge close to the manifold head of the pump to assist in setting system pressure and to periodically monitor system pressure.

Setting and adjusting the unloader pressure must be done with the system turned on. Start the system with the unloader backed off to the lowest pressure setting (counterclockwise direction). Squeeze the trigger and read the pressure on the gauge at the pump. Do not read pressure at the gun or nozzle. If more pressure is desired, release the trigger, turn adjusting cap one quarter turn clockwise. Squeeze the trigger and read the pressure. Repeat this process until the desired system pressure is reached. Thread locking nut up to adjusting cap and tighten set screw.

All high-pressure systems should have a secondary relief valve.

Set secondary relief valve 200–300 psi above the unloader setting.

Note: Pressure is not set at the factory.

SERVICE:

The unloader should be serviced on the same schedule as the seals in the pump. Refer to 67DX Service Manual for servicing of seals and valves, torque requirements and Diagnosis and Maintenance chart.

⚠ CAUTIONS AND WARNINGS

All high-pressure systems require a primary pressure regulating device (e.g. regulator, unloader) and a secondary pressure relief device (e.g. pop-off valve, relief valve). Failure to install such relief devices could result in personal injury or damage to pump or property. Cat Pumps does not assume any liability or responsibility for the operation of a customer's high-pressure system.

Read all CAUTIONS and WARNINGS before commencing service or operation of any high-pressure system. The CAUTIONS and WARNINGS are included in each Service Manual and with each Accessory Data sheet. CAUTIONS and WARNINGS can also be viewed online at www.catpumps.com/dynamic-literature/cautions-and-warnings or can be requested directly from Cat Pumps.

WARRANTY

View the Limited Warranty online at www.catpumps.com/literature/cat-pumps-limited-warranty