

DATA SHEET

7CP PLUNGER PUMPS



Brass Models: **7CP6110CS, 7CP6170**

Brass Gearbox Models: **7CP6110CSG1, 7CP6170G1, 7CP6170G118**

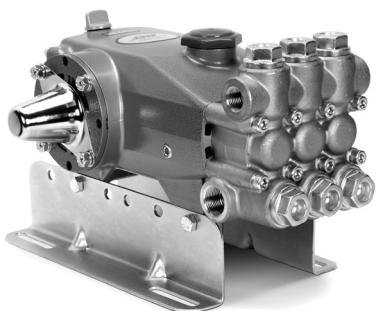

Model 7CP6170 Shown
(Mounting rails and shaft protector sold separately)

FEATURES

- Triplex plunger design ensures high efficiency and low pulsation.
- Belt-driven option provides precise flow settings.
- Gearbox models available with 1" or 1½" hollow shaft to fit most engines.
- Direct-drive option offers a compact footprint for electric motors with a NEMA or IEC frame, or SAE hydraulic motors with a bell housing/flexible coupler assembly.
- Pump comes standard with NBR seals. Alternative seal materials are available for higher temperature or chemical compatibility.

COMMON SPECIFICATIONS

	U.S.	Metric
Inlet Pressure Range	Flooded to 70 psi	Flooded to 4.8 bar
Max. Liquid Temperature (NBR)	140° F	60° C
Alternative seals available for higher temperatures up to 190° F		
Bore	0.866"	22 mm
Crankcase Capacity	38 oz	1.15 l
Inlet Ports (2)	¾" NPT(F)	¾" NPT(F)
Discharge Ports (2)	½" NPT(F)	½" NPT(F)
Shaft Diameter	0.945"	24 mm
Weight (7CP6110CS, 7CP6170)	30.8 lbs	14 kg
Weight (Gearbox Models)	38.8 lbs	17.6 kg
Dimensions (7CP6110CS)	13.48 x 9.55 x 6.83"	343 x 242.5 x 174 mm
Dimensions (7CP6170)	13.48 x 11.14 x 6.83"	343 x 283 x 174 mm
Dimensions (Gearbox Models)	13.48 x 12.31 x 6.83"	343 x 313 x 174 mm

SPECIFICATIONS

	U.S. Measure	Metric Measure
7CP6110CS		
Flow	10.5 gpm	40 lpm
Pressure Range	100–2000 psi	6.9–138 bar
Pump RPM*	1750 rpm	1750 rpm
Stroke	0.854"	21.7 mm
7CP6170		
Flow	11 gpm	41.6 lpm
Pressure Range	100–2000 psi	6.9–138 bar
Pump RPM*	1450 rpm	1450 rpm
Stroke	1.024"	26 mm
7CP6110CSG1		
Flow	10.0 gpm	38.0 lpm
Pressure Range	100–2000 psi	6.9–138 bar
Engine RPM	3400 rpm	3400 rpm
Stroke	0.854"	21.7 mm
7CP6170G1, 7CP6170G118		
Flow	12.0 gpm	45.4 lpm
Pressure Range	100–1800 psi	6.9–124 bar
Engine RPM	3264 rpm	3264 rpm
Stroke	1.024"	26 mm

*Pump minimum is 100 RPM.

ALTERNATE SPECIFICATIONS

	U.S. Measure	Metric Measure
7CP6170		
Flow	12.0 gpm	45.4 lpm
Pressure Range	100–1800 psi	6.9–124 bar
Pump RPM*	1600 rpm	1600 rpm

ALTERNATIVE SEAL CONFIGURATION

MATERIAL	SUFFIX CODE	MAXIMUM TEMPERATURE	
NBR	—	140° F	(60° C)
FPM	.0110	180° F	(82° C)
EPDM	.0220	160° F	(71° C)
HT	.3000	180° F	(82° C)
STHT	.3400	190° F	(88° C)

See **Tech Bulletin 002** for inlet conditions and RPM at high temperature.

PARTS LIST

ITEM	P/N	MATL	DESCRIPTION	QTY
5	126540	STCP R	Screw, HHC Sems (M8 x 20) (See Tech Bulletin 074)	8
8	131405	ALE	Cover, Bearing	1/2
9	49503	FBR	Shim, Split, 2-Piece, Outer	0-6
10	12393	NBR	O-Ring, Bearing Cover-70D	2
11	49190	NBR	Seal, Oil Crankshaft	1/2
12	49504	S	Shim, Split, 2-Piece, Inner	0-4
15	63479	STL	Bearing, Roller	2
20	48727	TNM	Rod, Connecting Assembly (See Tech Bulletin 074)	3
25	49498	FCM	Crankshaft, Single-End (M21.7) (7CP6110CS, 7CP6110CSG1)	1
	49649	FCM	Crankshaft, Single-End (M26) (7CP6170G1, 7CP6170G118)	1
	46963	FCM	Crankshaft, Dual-End (M26) (7CP6170)	1
30	131407	ALE	Cover, Blind Bearing (7CP6110CS, 7CP6110CSG1, 7CP6170G1, 7CP6170G118)	1
32	43211	ABS	Cap, Oil Filler	1
33	14177	NBR	O-Ring, Oil Filler Cap-70D	1
36	129343	RBR	Gasket, Flat	1
37	92241	PC	Gauge, Oil, Bubble with Gasket-80D (See Tech Bulletin 074)	1
38	44428	NBR	Gasket, Flat, Oil Gauge-80D	1
39	49948	ABS	Dip Stick (White)	1
40	125824	STCP R	Screw, HHC Sems (M6 x 16) (See Tech Bulletin 074)	4
48	25625	STCP	Plug, Drain (1/4" x 19 BSP)	1
49	23170	NBR	O-Ring, Drain Plug-70D	1
50	131403	ALE	Cover, Rear	1
51	14030	NBR	O-Ring, Rear Cover-70D	1
53	131400	ALE	Crankcase	1
64	46969	CM	Pin, Crosshead	3
65	46968	BBNP	Rod, Plunger	3
70	48281	NBR	Seal, Oil Crankcase	3
75	43328	S	Slinger, Barrier	3
90	48559	CC	Plunger, Ceramic (M22 x 55)	3
95	126555	STCP R	Stud, Plunger Retainer (M6 x 50)	3
96	43235	PTFE	Backup Ring, Plunger Retainer	3
97	17399	NBR	O-Ring, Plunger Retainer-80D	3
98	45891	CU	Gasket	3
99	46504	S	Retainer, Plunger (M6) (See Tech Bulletin 074)	3
100	46964	NY	Retainer, Seal	3
106	49644	NBR	Seal, Low-Pressure with SS-Spring	3
120	48279	BB	Case, Seal	3
121	13984	NBR	O-Ring, Seal Case-70D	3
127	48278	STG	V-Packing	6
128	48280	BB	Adapter, Male	3
162	43248	PTFE	Backup Ring, Seat	6
163	43249	NBR	O-Ring, Seat-80D	6
164	44718	S	Seat	6
166	43721	S	Valve	6
167	43751	S	Spring	6
168	44564	PVDF	Retainer, Spring	6
172	17617	NBR	O-Ring, Valve Plug-90D	6
174	43850	BB	Plug, Valve (See Tech Bulletin 074)	6
185	48274	FBB	Head, Manifold	1
188	126513	STCP R	Screw, HSH (M8 x 70) (See Tech Bulletin 074)	8
500	8081	—	Gearbox 1" Shaft (See Individual Data Sheet)	1
	8072	—	Gearbox 1 1/8" Shaft (See Individual Data Sheet)	1

Bold print part numbers are unique to a particular pump model. *Italics are optional items.*

R Components comply with RoHS Directive. For additional technical information see www.catpumps.com/literature/tech-bulletins.

MATERIAL CODES (Not Part of Part Number): ABS=ABS Plastic ALE=Aluminum Epoxy BB=Brass BBNP=Brass/Nickel Plated CC=Ceramic

CM=Chrome-moly CU=Copper EPDM=Ethylene Propylene Diene Monomer F=Cast Iron FBB=Forged Brass FBR=Fiber

FCM=Forged Chrome-moly FPM=Fluorocarbon NBR=Medium Nitrile (Buna-N) NY=Nylon PC=Poly Carbonate

PTFE=Pure Polytetrafluoroethylene PVDF=Polyvinylidene Fluoride RBR=Rubber S=304SS ST=Special PTFE

STG=Special Blend PTFE White STHT=Special PTFE High Temp STL=Steel STCP=Steel/Chrome Plated

STZP=Steel/Zinc Plated TNM=Special High Strength

EXPLODED VIEW

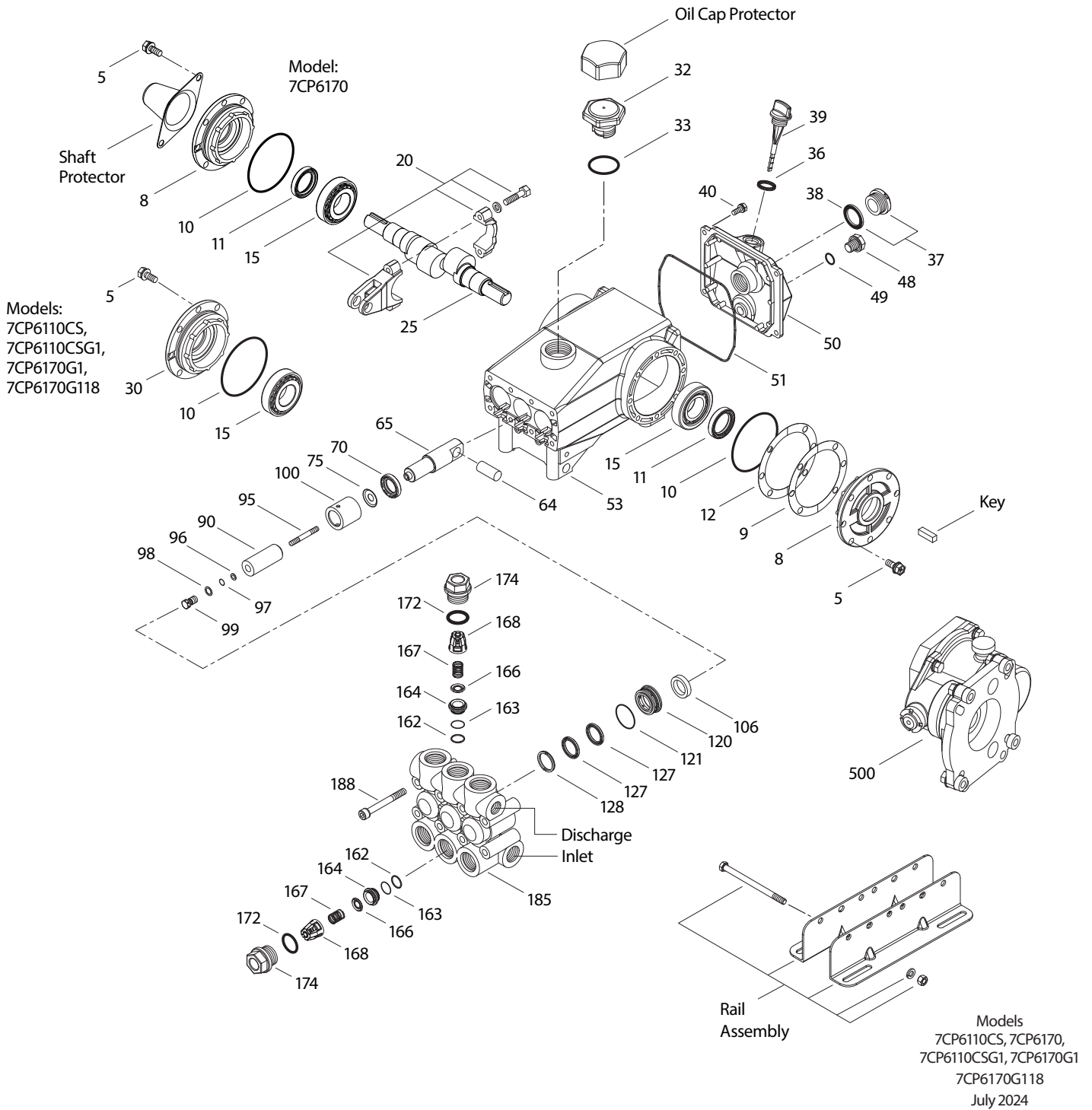

OPTIONAL PARTS AND ACCESSORIES

PART	DESCRIPTION	QTY
30067	Key (M8 x 7.5 x 25)	1
30613	Rail Assembly (5.75" See Dimensional Drawing)	1
76513	Rail Assembly (6.25" See Dimensional Drawing)	1
120220	Protector, Shaft (Model 7CP6170)	1
828710	Protector, Oil Cap	1
34334	Kit, Oil Drain (3/8" x 24") (Not Shown)	1
30206	Pulley, 10", 2 Groove "H" (Not Shown)	1
33000	Hub, "H", 24 mm (Not Shown)	1

SERVICE PARTS

PART	DESCRIPTION	QTY
76933	Kit, Seal-Standard NBR	1
34920	Kit, Valve-Standard NBR	2
6107	Oil, Bottle (21 oz) (Fill to Specific Crankcase Capacity Prior to Start-up)	2
6124	Gasket, Liquid (3 oz)	1
30696	Reverse Pliers (Not Shown)	1
816764	Head, Complete with NBR Seals and O-Rings	1

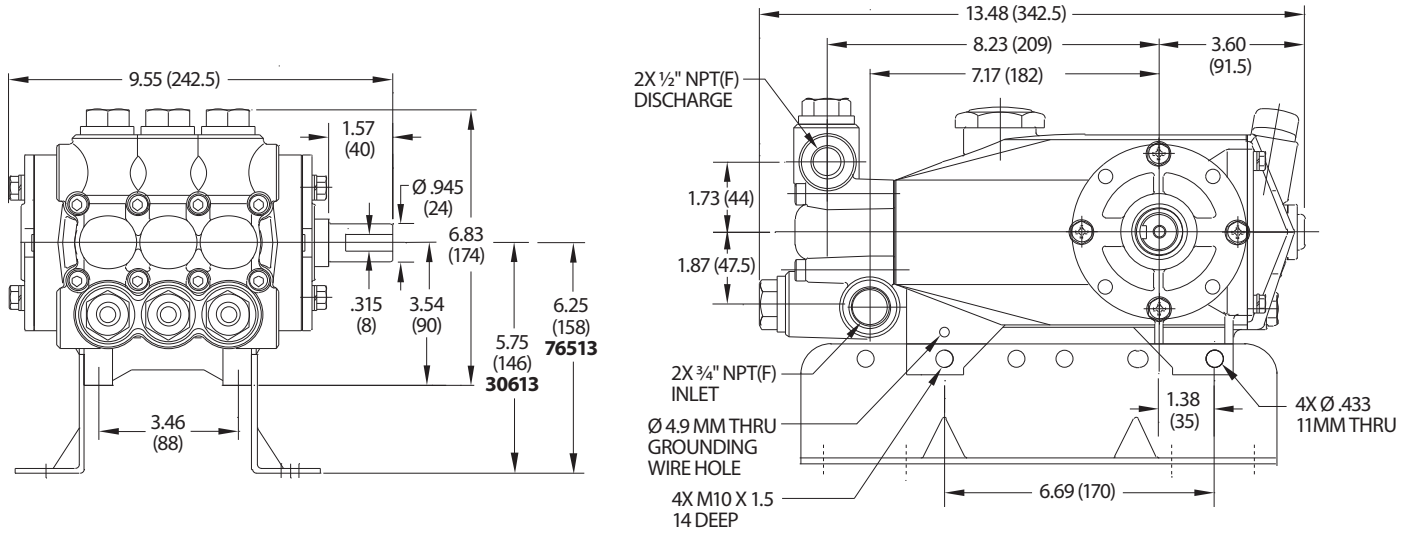

Model 7CP6110CS

SEAL KITS One (1) seal kit required per pump

PUMP MODELS	NBR (STD)	FPM (.0110)	EPDM (.0220) ♦	STHT (.3400)
7CP6110CS, 7CP6170, 7CP6110CSG1, 7CP6170G1, 7CP6170G118	76933	76950	31936*	76068

ITEM (Included in Seal Kits)					DESCRIPTION	QTY
97	17399	14160	46204	17399	O-Ring, Plunger Retainer	3
106	49644	49704	48650	76704	Seal, Low-Pressure with SS-Spring	3
121	13984	14333	701945	13984	O-Ring, Seal Case	3
127	48278	48278	48278	48278	V-Packing	6

♦ Silicone oil/grease required
 *Review material codes for individual items (STG may be used as alternative)

VALVE KITS Two (2) valve kits required per pump

PUMP MODELS	NBR (STD)	FPM (.0110)	EPDM (.0220) ♦	STHT (.3400)
7CP6110CS, 7CP6170, 7CP6110CSG1, 7CP6170G1, 7CP6170G118	34920	31256	31253	34920

ITEM (Included in Valve Kits)					DESCRIPTION	QTY
162	43248	43248	43248	43248	Backup Ring, Valve Seat	3
163	43249	44383	46206	43249	O-Ring, Valve Seat	3
164	44718	44718	44718	44718	Seat	3
166	43721	43721	43721	43721	Valve	3
167	43751	43751	43751	43751	Spring	3
168	44564	44564	44564	44564	Retainer, Spring	3
172	17617	11691	46207	17617	O-Ring, Valve Plug	3

♦ Silicone oil/grease required

⚠ CAUTIONS AND WARNINGS

All high-pressure systems require a primary pressure regulating device (e.g. regulator, unloader) and a secondary pressure relief device (e.g. pop-off valve, relief valve). Failure to install such relief devices could result in personal injury or damage to pump or property. Cat Pumps does not assume any liability or responsibility for the operation of a customer's high-pressure system. Read all CAUTIONS and WARNINGS before commencing service or operation of any high-pressure system. The CAUTIONS and WARNINGS are included in each Service Manual and with each Accessory Data sheet. CAUTIONS and WARNINGS can also be viewed online at www.catpumps.com/dynamic-literature/cautions-and-warnings or can be requested directly from Cat Pumps.

WARRANTY

View the Limited Warranty online at www.catpumps.com/literature/cat-pumps-limited-warranty