

DATA SHEET

7 FRAME PLUNGER PUMPS



Brass Model: 700

Gearbox Model: 700G1

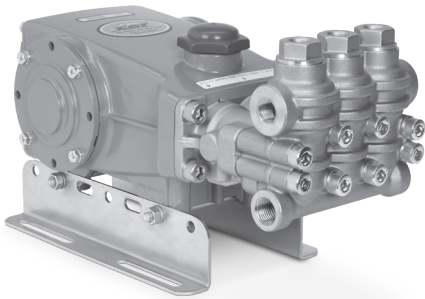

Model 700 shown
(Mounting rails sold separately)

FEATURES

- Triplex plunger design ensures high efficiency and low pulsation.
- Durable V-Packings are lubricated and cooled by the liquid being pumped.
- Belt-driven option provides precise flow setting.
- Stacked stainless steel valve design promotes long life and easy servicing.
- Direct-drive option offers a compact footprint for electric motors with a NEMA or IEC frame, or SAE hydraulic motors with a bell housing/flexible coupler assembly.
- Pump comes standard with NBR seals. Alternative seal materials are available for higher temperature or chemical compatibility.

COMMON SPECIFICATIONS

	U.S.	Metric
Inlet Pressure Range	Flooded to 60 psi	Flooded to 4.1 bar
Max. Liquid Temperature (NBR)	160° F	71° C
Alternate seals available for higher temperatures up to 190° F		
Bore	0.551"	14 mm
Stroke	0.945"	24 mm
Crankcase Capacity	25 oz	0.74 l
Inlet Ports (2)	½" NPT(F)	½" NPT(F)
Discharge Ports (2)	¾" NPT(F)	¾" NPT(F)
Shaft Diameter – Single End	0.945"	24 mm
Weight	28.2 lbs	12.8 kg
Dimensions	13.94 x 9.21 x 6.54"	354 x 234 x 166 mm

SPECIFICATIONS

MODEL 700

	U.S. Measure	Metric Measure
Flow	4.7 gpm	17.8 lpm
Pressure Range	100–5000 psi	6.9–345 bar
Pump RPM*	1750 rpm	1750 rpm

*Pump minimum is 100 RPM.

MODEL 700G1

	U.S. Measure	Metric Measure
Flow	4.5 gpm	17 lpm
Pressure Range	100–5000 psi	6.9–345 bar
Engine RPM	3465 rpm	3465 rpm

See Gearbox Data Sheet for additional information.

ALTERNATIVE SEAL CONFIGURATION

MATERIAL	SUFFIX CODE	MAXIMUM TEMPERATURE	
NBR	—	160° F	(71° C)
FPM	.0110	180° F	(82° C)
HT	.3000	180° F	(82° C)
STHT	.3400	190° F	(88° C)

See **Tech Bulletin 002** for inlet conditions and RPM at high temperature.

$$\text{DETERMINING THE PUMP RPM} \quad \frac{\text{Rated gpm}}{\text{Rated rpm}} = \frac{\text{Desired gpm}}{\text{Desired rpm}}$$

$$\text{DETERMINING THE REQUIRED HP} \quad \frac{\text{Hp (Electric Brake)}}{1460} = \frac{\text{gpm x psi}}{1460}$$

$$\text{DETERMINING MOTOR PULLEY SIZE} \quad \frac{\text{Motor Pulley OD}}{\text{Pump rpm}} = \frac{\text{Pump Pulley OD}}{\text{Motor rpm}}$$

Refer to pump **Service Manual** for repair procedure and additional technical information.

PARTS LIST

ITEM	P/N	MATL	DESCRIPTION	QTY
700/700G1				
5	125824	STCP R	Screw, HHC Sems (M6 x 16) (See Tech Bulletin 074)	8/4
8	133571	ALE	Cover, Bearing	1
9	815280	FBR	Shim, Split, 2-Piece	1
10	12393	NBR	O-Ring, Bearing Cover	2/1
11	43222	NBR	Seal, Oil, Crankshaft	1/0
15	43221	STL	Bearing, Roller	2
20	48863	TNM	Rod, Connecting (See Tech Bulletin 074)	3
25	119234	FCM	Crankshaft, Single-End (M24 with 60 mm Extension)	1
	46554	FCM	Crankshaft, Single-End (M24 with 34 mm Extension) (Model 700G1)	1
30	133572	ALE	Cover, Blind Bearing	1
32	44666	RTP	Cap, Oil Filler, Domed	1
33	14177	NBR	O-Ring, Oil Filler Cap-70D	1
37	92241	PC	Gauge, Oil, Bubble with Gasket-80D (See Tech Bulletin 074)	1
38	44428	NBR	Gasket, Flat, Oil Gauge-80D	1
40	125824	STCP R	Screw, HHC Sems (M6 x 16)	4
48	25625	STCP	Plug, Drain (1/4" x 19 BSP)	1
49	23170	NBR	O-Ring, Drain Plug-70D	1
50	133569	ALE	Cover, Rear	1
51	14047	NBR	O-Ring, Rear Cover-70D	1
53	133593	ALE	Crankcase with Guide Pins	1
54	27488	S	Pin, Guide	2
56	43240	POP	Pan, Oil	1
64	43237	CM	Pin, Crosshead	3
65	49892	SBZ	Rod, Plunger	3
69	126589	STCP R	Washer, Oil Seal	3
70	43228	NBR	Seal, Oil, Crankcase	3
75	43328	S	Slinger, Barrier	3
88	45697	S	Washer, Keyhole (M18 x 10)	3
90	45890	CC	Plunger (M14 x 72)	3
95	126558	STCP R	Stud, Plunger Retainer (M6 x 64.5)	3
96	43235	PTFE	Backup Ring, Plunger Retainer	3
97	17399	NBR	O-Ring, Plunger Retainer - 80D	3
98	45891	CU	Gasket, Plunger Retainer	3
99	46504	S	Retainer, Plunger (M6) (See Tech Bulletin 074)	3
100	45689	PVDF	Retainer, Seal, 2-Piece	3
101	43571	—	Wick, Long Tab	3
106	45188	NBR	Seal, Low-Pressure with S-Spring	3
110	49797	BB	Manifold, Inlet	1
112	11343	NBR	O-Ring, Inlet Manifold-70D	3
117	49679	S	Screw, HSH (M10 x 35) (See Tech Bulletin 074)	4
118	49680	S	Washer	4
121	14200	NBR	O-Ring, V-Packing Spacer-70D	3
122	49840	PTFE	Backup Ring, V-Packing Spacer	3
123	49839	NBR	O-Ring, V-Packing Spacer-90D	3
124	49838	BB	Spacer, V-Packing	3
126	45896	BB	Adapter, Female	3
127	45895	SNG	V-Packing	9
128	46567	BB	Adapter, Male	3
159	49861	PTFE	Backup Ring, Inlet Valve Seat	3
160	11346	NBR	O-Ring, Inlet Valve Seat-70D	3
161	49846	S	Seat, Inlet	3
162	49844	PTFE	Backup Ring, Discharge Valve Seat	3
163	49845	NBR	O-Ring, Discharge Valve Seat-70D	3
164	49843	S	Seat, Discharge	3
165	49847	PVDF	Retainer, Spring, Inlet	3
166	46562	S	Valve	6
167	43750	S	Spring	6
168	44565	PVDF	Retainer, Spring, Discharge	3
172	49382	NBR	O-Ring, Valve Plug-90D	3
173	49850	PTFB	Backup Ring, Valve Plug	3
174	49849	BB	Plug, Valve (See Tech Bulletin 074)	3
185	49798	BB	Head, Manifold	1
188	49852	S	Screw, HSH (M10 x 65) (See Tech Bulletin 074)	8
500	8071	—	<i>Gearbox, 1" (See 8071 Data Sheet) (Model 700G1)</i>	1

Italics are optional items. Bold print part numbers are unique to a particular pump model.

R Components comply with RoHS Directive. For additional technical information see www.catpumps.com/literature/tech-bulletins
 MATERIAL CODES (Not Part of Part Number): ALE=Aluminum Epoxy BB=Brass CC=Ceramic CM=Chrome-Moly CU=Copper F=Cast Iron
 FBR=Fiber FCM=Forged Chrome-moly FPM=Fluorocarbon NBR=Medium Nitrile (Buna-N) PC=Poly Carbonate PE=Polyethylene POP=Polypropylene
 PTFB=Polytetrafluoroethylene w/60% Bronze PTFE=Pure Polytetrafluoroethylene PVDF=Polyvinylidene RTP=Reinforced Composite S=304SS
 SBZ=304SS/Bronze SNG=Special Blend (Buna) ST4=Special PTFE 4 SHT=Special PTFE High-Temperature STL=Steel
 STCP=Steel/Chrome Plated STZP=Steel/Zinc Plated TNM=Special High Strength

Optional Parts and Accessories and Service Parts listed on page 3. Standard and Optional Seal and Valve Kits listed on page 4.

EXPLODED VIEW

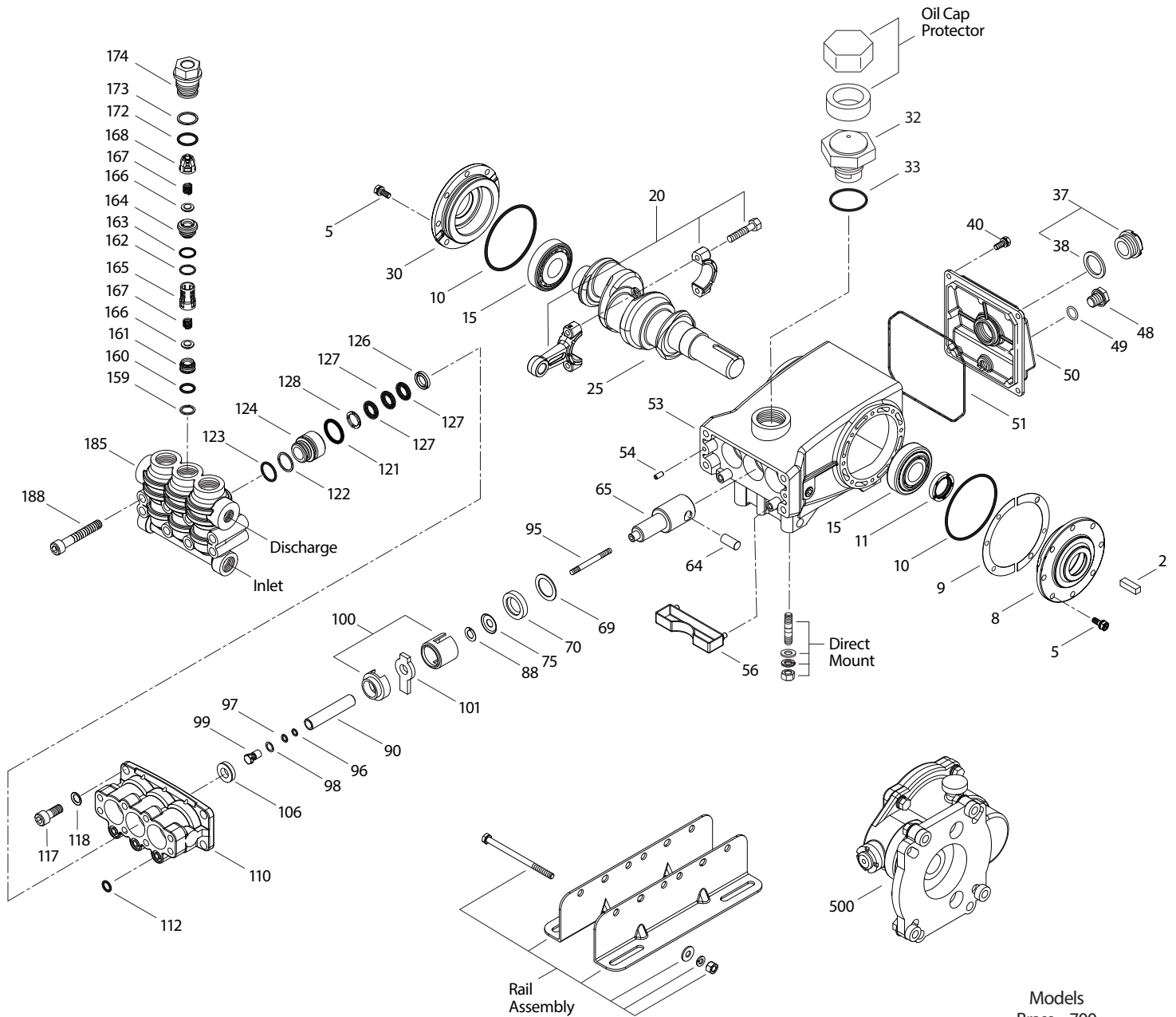

Models
Brass - 700
Gearbox - 700G1
October 2024

OPTIONAL PARTS AND ACCESSORIES

PART	DESCRIPTION	QTY
30067	Key (M8 x 7.5 x 25)	1
30660	Kit, Complete Mounting (Not Shown)	1
30611	Assembly, Rail (4.22" See Dimensional Drawing)	1
30645	Assembly, Rail (5.02" See Dimensional Drawing)	1
30243	Mount, Direct	1
828710	Protector, Oil Cap with Foam Gasket	1
34334	Kit, Oil Drain (3/8" x 24") (Not Shown)	1
30206	Pulley, 10", 2-Groove AB "H" Hub (Not Shown)	1
33000	Hub, "H", (24 mm) (3/8" x 24") (Not Shown)	1

SERVICE PARTS

PART	DESCRIPTION	QTY
76079	Kit, Seal - Standard NBR	1
76081	Valve Kit - Standard NBR	1
6107	Oil, Bottle (21 oz) ISO 68 Hydraulic (Fill to Specified Crankcase Capacity Prior to Start-up)	1-2
6110	Lube, Gear (16 oz Bottle), 80w-140 (to Fill 8071 Gearbox)	1
30696	Reverse Pliers	1
818537	Head, Complete with NBR Seals and O-Rings	1

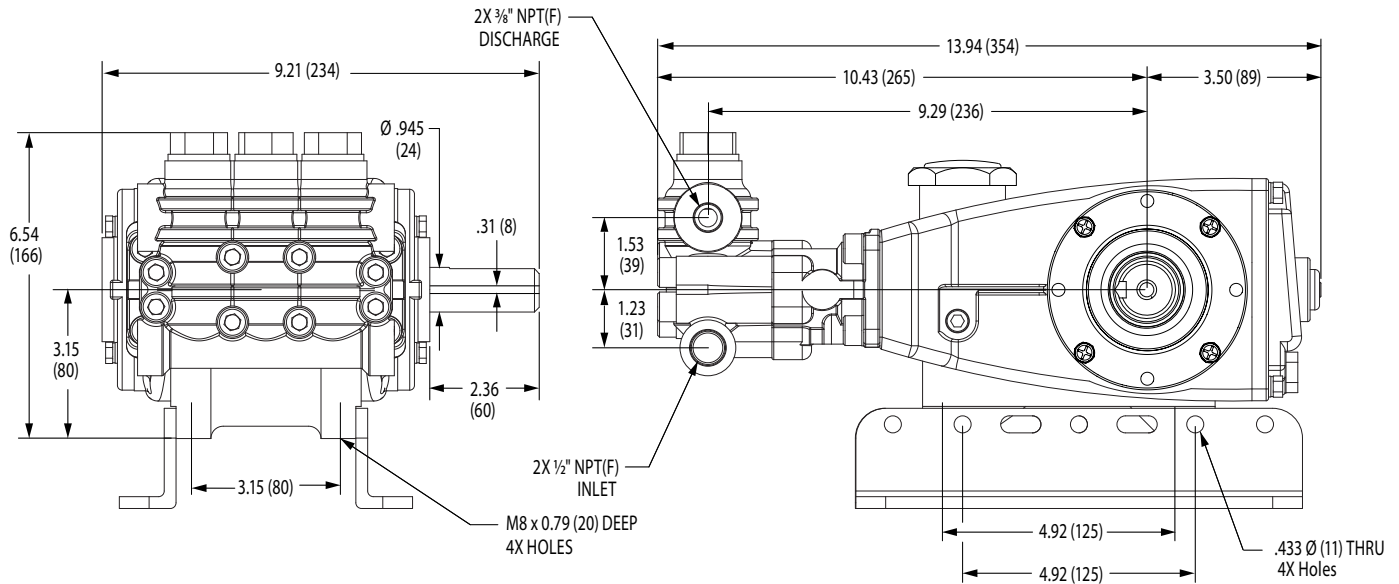

Model 700

SEAL KITS One (1) seal kit required per pump

PUMP MODELS	NBR (STD)	FPM (.0110)	NBR (.3400)
700, 700G1	76079	76032 *	76578 *

ITEM (Included in Seal Kits)				DESCRIPTION	QTY
97	17399	14160	17399	O-Ring, Plunger Retainer	3
101	43571	43571	43571	Wick, Long Tab	3
106	45188	—	—	Seal, Low-Pressure with S-Spring	3
	—	704649	704649	Seal, Low-Pressure with NIH-Spring	3
112	11343	14186	11343	O-Ring, Inlet Manifold	3
121	14200	11719	14200	O-Ring, V-Packing Spacer	3
122	49840	49840	49840	Backup Ring, V-Packing Spacer	3
123	49839	11686	49839	O-Ring, V-Packing Spacer	3
127	45895	704666	704666	V-Packing	3

* Review material codes for individual items (SNG and ST4 may be used as alternative)

VALVE KITS One (1) valve kit required per pump

PUMP MODELS	NBR (STD)	FPM (.0110)	NBR (.3400)
700, 700G1	76081	76034	76081

ITEM (Included in Valve Kits)				DESCRIPTION	QTY
159	49861	49861	49861	Backup Ring, Inlet Valve Seat	3
160	11346	11376	11346	O-Ring, Inlet Valve Seat	3
161	49846	49846	49846	Seat, Inlet	3
162	49844	49844	49844	Backup Ring, Discharge Valve Seat	3
163	49845	49894	49845	O-Ring, Discharge Valve Seat	3
164	49843	49843	49843	Seat	3
165	49847	49847	49847	Retainer, Spring, Inlet	3
166	46562	46562	46562	Valve	3
167	43750	43750	43750	Spring	3
168	44565	44565	44565	Retainer, Spring, Discharge	3
172	49382	49897	49382	O-Ring, Valve Plug	3
173	49850	49850	49850	Backup Ring, Valve Plug	3

⚠ CAUTIONS AND WARNINGS

All high-pressure systems require a primary pressure regulating device (e.g. regulator, unloader) and a secondary pressure relief device (e.g. pop-off valve, relief valve). Failure to install such relief devices could result in personal injury or damage to pump or property. Cat Pumps does not assume any liability or responsibility for the operation of a customer's high-pressure system. Read all CAUTIONS and WARNINGS before commencing service or operation of any high-pressure system. The CAUTIONS and WARNINGS are included in each Service Manual and with each Accessory Data sheet. CAUTIONS and WARNINGS can also be viewed online at www.catpumps.com/dynamic-literature/cautions-and-warnings or can be requested directly from Cat Pumps.

WARRANTY

View the Limited Warranty online at www.catpumps.com/literature/cat-pumps-limited-warranty