

DATA SHEET

CP MOTORIZED PUMP UNITS



**Motors: 8023ES, 8024ES,
8025ES**

**Used on
Pump Models: 3CP1120, 3CP1130,
3CP1140**

**Motors: 8026ES, 8027ES,
8028ES, 8029ES**

**Used on
Pump Models: 5CP2140WCS,
5CP2150W**

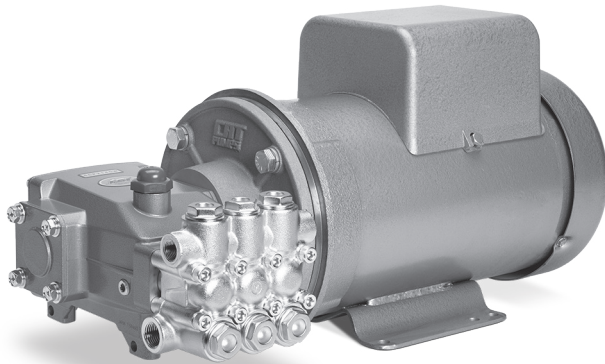

Model 5CP2140WBD31 Shown

MOTORIZED UNIT FEATURES

- Motorized unit design eliminates belt selection, sizing and adjustments.
- Compact direct mounting design reduces the space required compared to belt or gearbox drive assemblies.
- Ease of assembly reduces fabrication costs.
- Motors:  CSA Energy Verified Master Contract (MC) 183051

 UL Recognized Components

COMMON SPECIFICATIONS

	U.S.	Metric
Inlet Pressure Range	Flooded to 70 psi	Flooded to 4.9 bar
Maximum RPM	1725 rpm	1725 rpm
Motor Frequency	60 Hz	60 Hz
Motor Enclosure Type	TEFC	TEFC

INSTRUCTIONS

Before installing the motorized pump unit, check the incoming voltage to ensure it does not exceed the motor rating, as this will result in motor damage. Instructions for electrical connections are on a decal on the motor housing.

Qualified or trained personnel should install equipment following the National Electrical Code, local codes and with NEMA MG2.

Review your application flow and pressure requirements. Exceeding the rated pressure of the motorized unit may cause overheating of the motor and a high amp draw, resulting in shortened motor life. Before operation, see the Pump and Motor Lubrication section.

CAUTION

Some Motor Models Do Not Contain A Thermal Protector

Install a separate over-current protection device to prevent motor burnout and possible fire damage due to an overloaded or stalled motor. The motor must be adequately grounded.

CONNECTING PUMP TO ELECTRIC MOTOR

1. Remove the four (4) hex head combination screws from the bearing cover and set aside.
2. Rotate the pump shaft so the keyway is toward the back of the pump.
3. Insert the key into the pump shaft. The beveled end should be toward the pump and the flat surface should be horizontal with the shaft keyway to ensure the key is completely seated. If the key is installed improperly, the shaft may not fit into the motor.
4. Slip the lock washer and washer onto the hex head shaft retaining screw. Apply Loctite® 242® onto the screw threads and thread the screw into the pump shaft. Torque to 110 in-lbs (12 Nm)
5. Install the mounting flange onto the pump with the extended collar toward the pump and side vents to the right and left. Line up the four unthreaded holes with the holes on the bearing cover.
6. Apply a small amount of Loctite® 242® to the four (4) flat-head hex screws and secure the mounting flange assembly to the pump. Torque to 60–70 in-lbs (6.6–7.7 Nm).
7. Apply Loctite® 242® to the two (2) set screws and thread them into the motor shaft, only partially into the keyway.
8. Apply anti-seize lubricant (PN 6106) to the pump shaft and inside diameter of the motor shaft.
9. Carefully insert the pump into the hollow motor shaft until the flange is flush with the motor. Ensure the key in the pump shaft lines up with the keyway of the motor shaft.
10. Secure the pump with the mounting flange to the motor with four (4) lock washers and four (4) hex head screws. Torque to 50–60 in-lbs (5.5–6.6 Nm).
11. Use a 5/32" hex wrench to secure the set screws through the side vent in the mounting flange. Torque to 60–75 in-lbs (6.6–8.3 Nm).

Loctite and 242 are registered trademarks of the Henkel Corporation.

MOUNTING FLANGE COMPONENTS

8001 Assembly Mount (3CP – 1.5 HP)

1	34307	Flange, Mount
2	34162	Screw, Set (10–32 x 1/2")
4	34160	Screw, HH (3/8"–16 x 1.25")
4	30921 R	Lockwasher (3/8")
1	30047	Key (M5 x 5 x 24)
1	6106	Anti-seize
1	32145	Screw, Assembly HH (M8 x 20)
4	34379	Screw, FH (M6 x 20)
4	126745 R	Lockwasher (M6)

8002 Assembly Mount (3CP – 3 HP)

1	34308	Flange, Mount
2	34162	Screw, Set (10–32 x 1/2")
4	32143	Screw, HH (1/2"–13 x 1.25")
4	126570 R	Lockwasher (1/2")
1	30047	Key (M5 x 5 x 24)
1	6106	Anti-seize
1	32145	Screw, Assembly, HH (M8 x 20)
4	34379	Screw, FH (M6 x 20)
4	126745 R	Lockwasher (M6)

8003 Assembly Mount (5CP – 3 HP, 5 HP)

1	34309	Flange, Mount
2	34162	Screw, Set (10–32 x 1/2")
4	32143	Screw, HH (1/2"–13 x 1.25")
4	126570 R	Lockwasher (1/2")
1	30057	Key (M6 x 6 x 25)
1	6106	Anti-seize
1	32145	Screw, Assembly HH (M8 x 20)
4	46403	Screw, FH (M8 x 25)
4	126746 R	Lockwasher (M8)

R Components comply with RoHS Directive

MOTOR WARRANTY

The motor manufacturer warrants all electric motors to be free from defects of material and workmanship for one year from the date of shipment. For warranty consideration, ship the defective motor PREPAID directly to Baldor.

PUMP LUBRICATION

Before starting the pump, fill the crankcase per specifications with Cat Pumps High-Pressure Pump Oil. For best results, perform an initial oil change after the first 50 hours of operation and every 500 hours thereafter.

MOTOR LUBRICATION

This is a ball bearing motor. The bearings have been lubricated at the factory. No lubricant needs to be added unless motor has been stored for over a year. Baldor motors are typically pre-greased with Mobil Polyrex™ EM.

Overgreasing bearings can cause premature failure. The motor is equipped with an Alemite fitting. Clean the tip of the fitting and apply grease with a gun. Use 1 to 2 strokes. Any excess may drip out the bottom drain during the first 20 minutes of operation.

Note: Keep grease clean. Lubricate the motor when it is not turning. Remove and replace drain plugs when not turning. Do not mix petroleum grease and silicone grease in motor bearings.

3CP MOTORIZED PUMP UNITS

MOTORIZED UNITS	3CP1130BD151 3CP1231BD151	3CP1120BD31 3CP1221BD131	3CP1120BD33 3CP1221BD33	3CP1130BD31 3CP1231BD31
Shipping Unit Weight	79 lbs	113 lbs	92 lbs	113 lbs
Shipping Unit Dimensions	26.0" x 16.5" x 16.0"	27.5" x 18.5" x 17.5"	27.5" x 18.5" x 17.5"	27.5" x 18.5" x 17.5"
PUMPS	3CP1130, 3CP1231	3CP1120, 3CP1221	3CP1120, 3CP1221	3CP1130, 3CP1231
Flow	2.4 gpm	4.2 gpm	4.2 gpm	2.4 gpm
Pressure Range	100–900 psi	100–1000 psi	100–1000 psi	100–1700 psi
MOTORS	8023ES	8024ES	8025ES	8024ES
Assembly Mount — REQUIRED	8001	8002	8002	8002
Horsepower	1.5 hp	3.0 hp	3.0 hp	3.0 hp
Phase	Single	Single	Three	Single
RPM	1725 rpm	1725 rpm	1750 rpm	1725 rpm
Frame Size	56CZY, TEFC	184TCZ, TEFC	182TCZ, TEFC	184TCZ, TEFC
Hertz	60 Hz	60 Hz	60 Hz	60 Hz
Volts	115/208/230V	230V	208–230/460V	230V
Maximum Amps	12.8/6.7/6.4 Amps	13.2 Amps	8.6–8.2/4.1 Amps	13.2 Amps
Service Factor	1.15	1.0	1.15	1.0
Maximum Ambient Temperature	104° F	104° F	104° F	104° F
Shaft Diameter (Hollow)	16.5 mm	16.5 mm	16.5 mm	16.5 mm
Thermal Overload	No	Yes	No	Yes
Capacitor Start	Yes	Yes	No	Yes
Insulation	Class B	Class F	Class F	Class F

3CP MOTORIZED PUMP UNITS

MOTORIZED UNITS	3CP1130BD33 3CP1231BD33	3CP1140BD31 3CP1241BD31	3CP1140BD33 3CP1241BD31
Shipping Unit Weight	92 lbs	113 lbs	92 lbs
Shipping Unit Dimensions	27.5" x 18.5" x 17.5"	27.5" x 18.5" x 17.5"	27.5" x 18.5" x 17.5"
PUMPS	3CP1130, 3CP1231	3CP1140, 3CP1241	3CP1140, 3CP1241
Flow	2.4 gpm	3.6 gpm	3.6 gpm
Pressure Range	100–1700 psi	100–1200 psi	100–1200 psi
MOTORS	8025ES	8024ES	8025ES
Assembly Mount — REQUIRED	8002	8002	8002
Horsepower	3.0 hp	3.0 hp	3.0 hp
Phase	Three	Single	Three
RPM	1750 rpm	1725 rpm	1750 rpm
Frame Size	182TCZ, TEFC	184TCZ, TEFC	182TCZ, TEFC
Hertz	60 Hz	60 Hz	60 Hz
Volts	208–230/460V	230V	208–230/460V
Maximum Amps	8.6–8.2/4.1 Amps	13.2 Amps	8.6–8.2/4.1 Amps
Service Factor	1.15	1.0	1.15
Maximum Ambient Temperature	104° F	104° F	104° F
Shaft Diameter (Hollow)	16.5 mm	16.5 mm	16.5 mm
Thermal Overload	No	Yes	No
Capacitor Start	No	Yes	N/A
Insulation	Class F	Class F	Class F

5CP MOTORIZED PUMP UNITS

MOTORIZED UNITS	5CP2140WBD31 3.0 HP	5CP2140WBD33 3.0 HP	5CP2150WBD31 3.0 HP
Shipping Unit Weight	123 lbs	99 lbs	123 lbs
Shipping Unit Dimensions	27.5" x 18.5" x 17.5"	27.5" x 18.5" x 17.5"	27.5" x 18.5" x 17.5"
PUMPS	5CP2140WCS	5CP2140WCS	5CP2150W
Flow	4.0 gpm	4.0 gpm	5.0 gpm
Pressure Range	100–1100 psi	100–1100 psi	100–900 psi
MOTORS	8026ES	8027ES	8026ES
Assembly Mount — REQUIRED	8003	8003	8003
Horsepower	3.0 hp	3.0 hp	3.0 hp
Phase	Single	Three	Single
RPM	1725 rpm	1750 rpm	1725 rpm
Frame Size	184TC, TEFC	182TCZ, TEFC	184TC, TEFC
Hertz	60 Hz	60 Hz	60 Hz
Volts	230V	208–230/460V	230V
Maximum Amps	13.2 Amps	8.6–8.2/4.1 Amps	13.2 Amps
Service Factor	1.0	1.15	1.0
Maximum Ambient Temperature	104° F	104° F	104° F
Shaft Diameter (Hollow)	20 mm	20 mm	20 mm
Thermal Overload	Yes	No	Yes
Capacitor Start	Yes	No	Yes
Insulation	Class F	Class F	Class F

MOTORIZED UNITS	5CP2150WBD33 3.0 HP	5CP2140WBD51 5.0 HP	5CP2140WBD53 5.0 HP
Shipping Unit Weight	99 lbs	129 lbs	113 lbs
Shipping Unit Dimensions	27.5" x 18.5" x 17.5"	27.5" x 18.5" x 17.5"	27.5" x 18.5" x 17.5"
PUMPS	5CP2150W	5CP2140WCS	5CP2140WCS
Flow	5.0 gpm	4.0 gpm	4.0 gpm
Pressure Range	100–900 psi	100–1800 psi	100–1800 psi
MOTORS	8027ES	8028ES	8029ES
Assembly Mount — REQUIRED	8003	8003	8003
Horsepower	3.0 hp	5.0 hp	5.0 hp
Phase	Three	Single	Three
RPM	1750 rpm	1725 rpm	1750 rpm
Frame Size	182TCZ, TEFC	184TC, TEFC	184TC, TEFC
Hertz	60 Hz	60 Hz	60 Hz
Volts	208–230/460V	208–230V	208–230/460V
Maximum Amps	8.6–8.2/4.1 Amps	22.5/26.0 Amps	13.9–13.4/6.7 Amps
Service Factor	1.15	1.0	1.0
Maximum Ambient Temperature	104° F	104° F	104° F
Shaft Diameter (Hollow)	20 mm	20 mm	20 mm
Thermal Overload	No	No	No
Capacitor Start	No	Yes	No
Insulation	Class F	Class F	Class F

Refer to individual Pump Data Sheet and Service Manual for maintenance parts, service procedures and additional specifications.

5CP MOTORIZED PUMP UNITS

MOTORIZED UNITS	5CP2150WBD51	5CP2150WBD53
	5.0 HP	5.0 HP
Shipping Unit Weight	129 lbs	113 lbs
Shipping Unit Dimensions	27.5" x 18.5" x 17.5"	27.5" x 18.5" x 17.5"
PUMPS	5CP2150W	5CP2150W
Flow	5.0 gpm	5.0 gpm
Pressure Range	100–1450 psi	100–1450 psi
MOTORS	8028ES	8029ES
Assembly Mount— REQUIRED	8003	8003
Horsepower	5.0 hp	5.0 hp
Phase	Single	Three
RPM	1725 rpm	1750 rpm
Frame Size	184TC, TEFC	184TC, TEFC
Hertz	60 Hz	60 Hz
Volts	208–230V	208–230/460V
Maximum Amps	22.5/23.5 Amps	13.9–13.4/6.7 Amps
Service Factor	1.0	1.0
Maximum Ambient Temperature	104° F	104° F
Shaft Diameter (Hollow)	20 mm	20 mm
Thermal Overload	No	No
Capacitor Start	Yes	No
Insulation	Class F	Class F

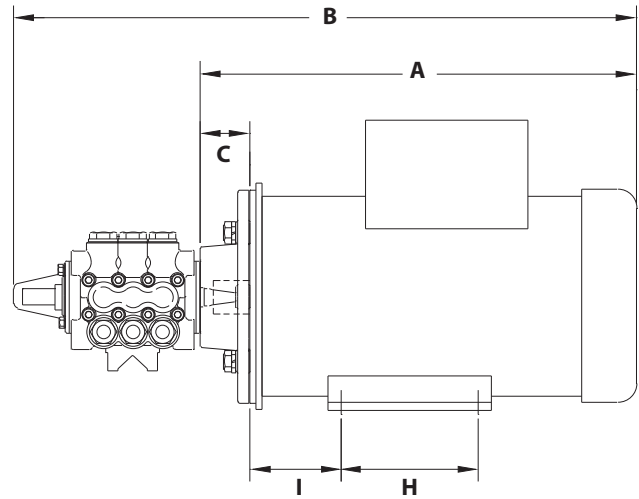
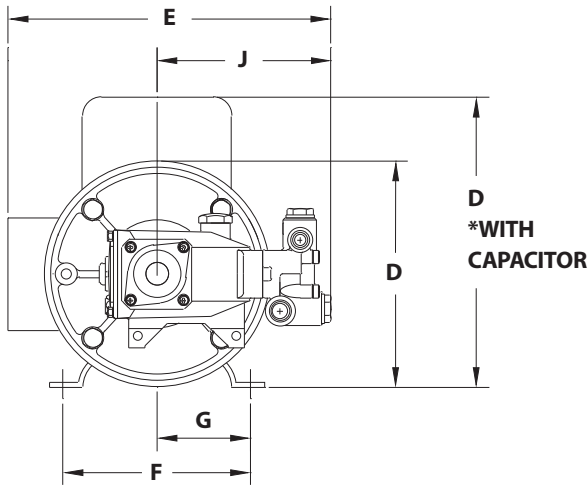

MOTOR	PUMP/SHAFT	A		B		C		D		E	
8023ES (1.5 hp 1 ph)	3CP (16.5mm)	14.62"	371 mm	22.06"	560 mm	2.00"	51 mm	*8.38"	213 mm	12.18"	309 mm
8024ES (3 hp 1 ph)	3CP (16.5mm)	15.92"	404 mm	23.36"	593 mm	1.98"	50 mm	*11.56"	294 mm	13.43"	341 mm
8025ES (3 hp 3 ph)	3CP (16.5mm)	17.42"	442 mm	24.81"	630 mm	1.98"	50 mm	8.9"	226 mm	12.81"	325 mm
8026ES (3 hp 1 ph)	5CP (20mm)	15.92"	404 mm	24.81"	630 mm	1.98"	50 mm	*11.56"	294 mm	14.39"	366 mm
8027ES (3 hp 3 ph)	5CP (20mm)	16.01"	407 mm	24.46"	621 mm	1.98"	50 mm	8.9"	226 mm	13.77"	350 mm
8028ES (5 hp 1 ph)	5CP (20mm)	17.42"	442 mm	24.00"	618 mm	1.98"	50 mm	*11.56"	294 mm	13.77"	350 mm
8029ES (5 hp 3 ph)	5CP (20mm)	17.39"	442 mm	23.97"	609 mm	1.98"	50 mm	9.00"	229 mm	13.77"	350 mm

MOTOR	PUMP/SHAFT	F		G		H		I		J	
8023ES (1.5 hp 1 ph)	3CP (16.5mm)	4.88"	124 mm	2.44"	62 mm	3.00"	76 mm	3.06"	78 mm	6.93"	176 mm
8024ES (3 hp 1 ph)	3CP (16.5mm)	7.50"	191 mm	3.75"	95 mm	5.50"	140 mm	3.62"	92 mm	6.93"	176 mm
8025ES (3 hp 3 ph)	3CP (16.5mm)	7.50"	191 mm	3.75"	95 mm	5.50"	140 mm	3.62"	92 mm	6.93"	176 mm
8026ES (3 hp 1 ph)	5CP (20mm)	7.50"	191 mm	3.75"	95 mm	5.50"	140 mm	3.62"	92 mm	7.89"	200 mm
8027ES (3 hp 3 ph)	5CP (20mm)	7.50"	191 mm	3.75"	95 mm	5.50"	140 mm	3.62"	92 mm	7.89"	200 mm
8028ES (5 hp 1 ph)	5CP (20mm)	7.50"	191 mm	3.75"	95 mm	5.50"	140 mm	3.62"	92 mm	7.89"	200 mm
8029ES (5 hp 3 ph)	5CP (20mm)	7.50"	191 mm	3.75"	95 mm	5.50"	140 mm	3.62"	92 mm	7.89"	200 mm

⚠ CAUTIONS AND WARNINGS

All high-pressure systems require a primary pressure regulating device (e.g. regulator, unloader) and a secondary pressure relief device (e.g. pop-off valve, relief valve). Failure to install such relief devices could result in personal injury or damage to pump or property. Cat Pumps does not assume any liability or responsibility for the operation of a customer's high-pressure system. Read all CAUTIONS and WARNINGS before commencing service or operation of any high-pressure system. The CAUTIONS and WARNINGS are included in each Service Manual and with each Accessory Data sheet. CAUTIONS and WARNINGS can also be viewed online at www.catpumps.com/dynamic-literature/cautions-and-warnings or can be requested directly from Cat Pumps.

WARRANTY

View the Limited Warranty online at www.catpumps.com/literature/cat-pumps-limited-warranty