

DATA SHEET

HIGH-PRESSURE PULSE PUMPS

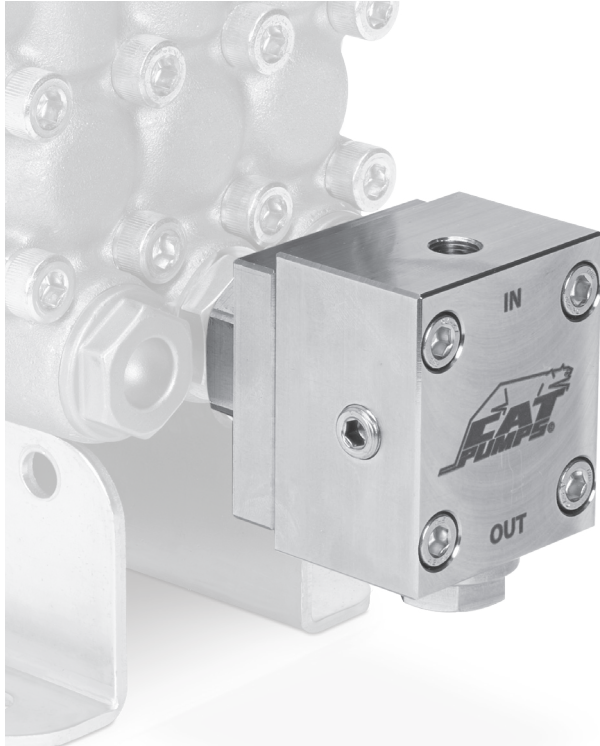

Stainless Steel 6340, 6341
Models:



FEATURES

- Applies chemicals for cleaning at pressures up to 2000 psi.
- Eliminates harsh chemicals from being pumped through the main pump.
- Conveniently mounts into any inlet valve chamber on the main pump with an adapter.
- The pulse pump body can be rotated to four different positions to provide convenient plumbing configurations.

SPECIFICATIONS	U.S. Measure	Metric Measure
Pressure Range	100–2000 psi	6.9–138 bar
Maximum Injection Rate	10.5 gph	39.7 lph
RPM Range	1000–1800 rpm	1000–1800 rpm
Maximum Inlet Pressure of Drive Pump	5 psi	0.35 bar
Maximum Liquid Temp.	130° F	54° C
Inlet Port (1)	1/8" NPT(F)	1/8" NPT(F)
Discharge Port (1)	1/8" NPT(F)	1/8" NPT(F)
Adapter Port (1)	1/4" NPT(F)	1/4" NPT(F)
Diaphragm Material (6340)	EPDM	EPDM
Diaphragm Material (6341)	FPM	FPM
Weight	2.1 lbs	0.95 kg
Dimensions	2.4 x 2.0 x 2.68"	61 x 51 x 68 mm

MAXIMUM INJECTION RATE

Pump RPM	Injection Rate	Injection Rate
1000	5.5 gph	20.8 lph
1100	7.0 gph	26.5 lph
1200	8.0 gph	30.3 lph
1300	9.0 gph	34.1 lph
1400	9.5 gph	36.0 lph
1500	10.0 gph	37.6 lph
1600	10.5 gph	39.7 lph
1700	10.5 gph	39.7 lph
1800	10.5 gph	39.7 lph

SELECTION

Select proper valve plug assembly kit to match the appropriate pump model.

6340, 6341 VALVE PLUG ASSEMBLY KITS

Pump Models	Part Number
335, 435	991616
3CP1120, 3CP1130, 3CP1140, 310, 340, 350, 5CP2120W, 5CP2140WCS, 5CP2150W, 5SP30ELU, 5SP35ELU, 5SP40ELU	31227
45, 5CP3105CSS, 5CP3110CSS, 5CP3120, 5CP3120CSS, 5CP3150CSS, 5CP3160CSS, 5CP5120, 5CP5135CSS, 5CP5140CSS	31233
56, 60	31228
530, 550, 650, 660, 1050, 5CP6120, 5CP6180CSS, 5CP6190, 7CP6110CS, 7CP6170	31232

INSTALLATION

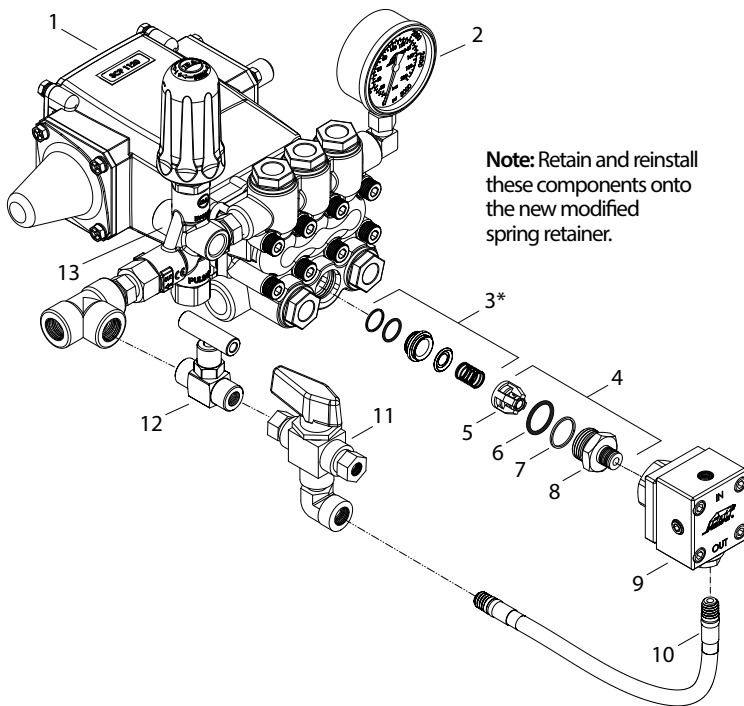

1	Plunger Pump
2	Gauge
3	Valve Components
4	Valve Plug Assembly Kit
5	Modified Spring Retainer
6	O-Ring
7	Backup Ring (31228 and 31233 Only)
8	Modified Valve Plug
9	Pulse Pump
10	High-Pressure Discharge Hose
11	3-Way Ball Valve, Closed Center (PN 992043 or Equivalent)
12	Needle Valve (PN 992040 or Equivalent)
13	Unloader

*Reinstall spring, valve, valve seat, O-ring, and backup ring from original valve assembly onto the modified spring retainer.

Plunger Pump Conversion

1. Remove one of the three inlet valve plugs from the discharge manifold.
2. Remove complete valve assembly from valve chamber.
3. Separate spring retainer from valve seat.
4. Install valve and spring onto valve seat, then install new modified spring retainer onto valve seat.
5. Install modified valve assembly into any inlet valve chamber.
6. On valve plug assembly kits 31227 and 31232, lubricate and install new valve plug O-ring around large end of modified valve plug. On valve plug assembly 31228 and 31233, lubricate and install new backup ring and then new O-ring around large end of modified valve plug.
7. Thread modified valve plug into valve chamber and torque to 870 in-lbs, 72.5 ft-lbs or 98 N-m.
8. Use PTFE thread tape or pipe thread sealant on exposed threads of modified valve plug. Thread pulse pump onto valve plug assembly kit and position pulse pump to meet established plumbing needs.

Note: Pulse pump can be rotated to be used in any position.

9. Attach any standard high-pressure hose to 1/8" NPT(F) "OUT" port on pulse pump, then connect to the ball valve and metering valve combination downstream from the unloader.

Piston Pump Conversion

1. Remove discharge manifold from the piston pump.
2. Replace with new pulse pump manifold and associated parts, and a new flat valve kit.
3. Place pulse pump manifold with three cylinder holes facing upwards.
4. In the cylinder hole with the deeper counterbore, install one white PTFE seal washer and one spring retainer (without nylon insert).
5. Install heavy-duty spring, standard flat valve spring, flat valve, flat seat and spacer into this same deep cylinder hole.
6. In the remaining two cylinder holes, first install one white PTFE seal washer and then a complete flat valve kit.
7. Remove existing shims from each cylinder bolt. Since the number of shims may change with the manifold, refer to Tech Bulletin 017 for proper shimming procedure. Mount pulse pump manifold to pump.
8. Thread 1/2" NPT(M) x 1/4" NPT(M) hex nipple into the deeper special 1/2" NPT(F) port on the top of the pulse pump manifold.
9. Apply Loctite® 242® to exposed threads of hex nipple. Thread pulse pump into hex nipple and position pulse pump to meet established plumbing needs.

Note: Pulse pump can be rotated to be used in any position.

11. Attach any standard high-pressure hose to 1/8" NPT(F) "OUT" port on pulse pump, then connect to the ball valve and metering valve combination downstream from the unloader.

OPERATION

Note: A needle valve (PN 992040 or equivalent) and closed center 3-way ball valve (PN 992043 or equivalent) are required to properly operate the pulse pump.

1. Ensure pump is connected to a water supply but is NOT running.
2. Turn water supply on, open trigger gun and start up pump.
3. Bring pump up to operating pressure and set regulating devices.

NOTICE Main pump inlet pressure must not exceed 5 psi.

4. Open 3-way ball valve to bypass port.
5. Ensure chemical flows through the pulse pump and comes out the bypass port of 3-way ball valve.
6. Allow chemical to flow out of bypass port of 3-way ball valve, then switch 3-way ball valve to discharge port.
7. Adjust metering valve to the desired amount of chemical/water mixture.

EXPLODED VIEW

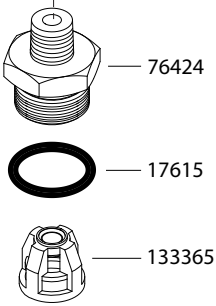
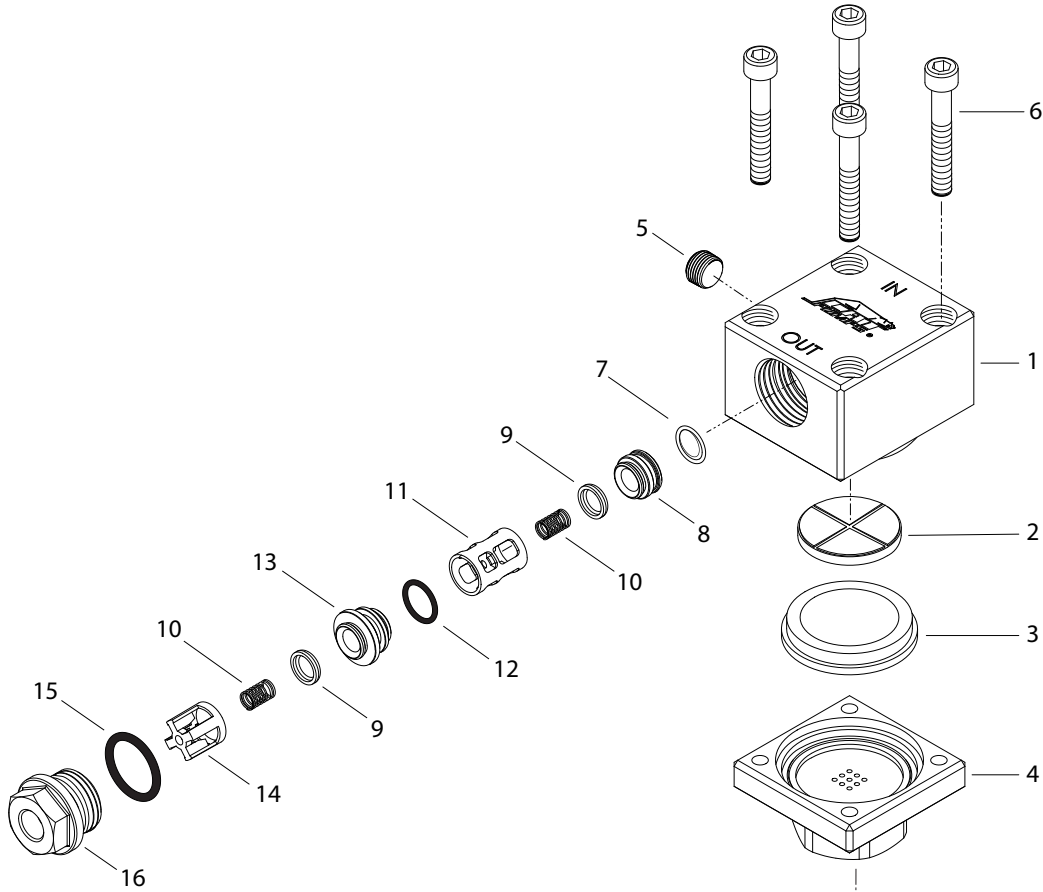

31227 Valve Plug Assembly Kit

3CP1120, 3CP1130, 3CP1140, 310, 340, 350, 5CP2120W, 2140WCS, 2150W, 5SP30ELU, 5SP35ELU, 5SP40ELU

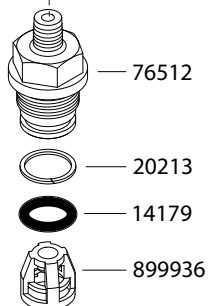

31228 Valve Plug Assembly Kit

56, 60

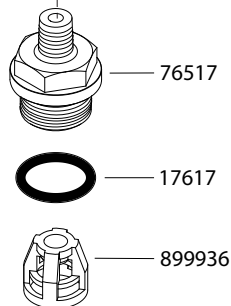

31232 Valve Plug Assembly Kit

530, 550, 650, 660, 1050, 5CP6120, 5CP6180CSS, 5CP6190, 7CP6110CS, 7CP6170

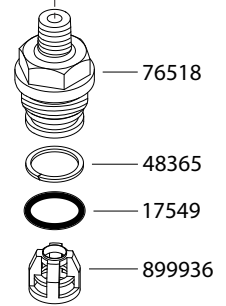

31233 Valve Plug Assembly Kit

45, 5CP3105CSS, 5CP3110CSS, 5CP3120, 5CP3120CSS, 5CP3150CSS, 5CP3160CSS, 5CP5120, 5CP5120CSS, 5CP5140CSS

PARTS LIST

ITEM	PN	MATL	DESCRIPTION	QTY
1	—	S	Body, Pump (with Logo)	1
2	31202	D	Spacer (6340)	1
	31298	CPVC	Spacer (6341)	1
3	31201	EPDM	Diaphragm (6340)	1
	31297	FPM	Diaphragm (6341)	1
4	—	S	Body, Diaphragm	1
5	31203	S	Plug, 1/8" NPT(M)	1
6	31362	STZP	Screw (M6 x 45)	4
7	—	FPM	O-Ring, Inlet Valve	1

ITEM	PN	MATL	DESCRIPTION	QTY
8	—	S	Seat, Inlet Valve	1
9	—	S	Valve	2
10	—	S	Spring	2
11	—	PVDF	Retainer, Inlet Valve	1
12	—	FPM	O-Ring, Discharge Valve	1
13	—	S	Seat, Discharge Valve	1
14	—	PVDF	Retainer, Discharge Valve	1
15	—	FPM	O-Ring, Valve Plug	1
16	—	S	Plug, Valve	1
17	77044	FPM	Kit, Valve (Includes: 7–15)	1

Bold print part numbers are unique to a particular pump model. Italics are optional items. MATERIAL CODES (Not Part of Part Number):
 CPVC=Chlorinated Polyvinyl Chloride D= Acetal EPDM= Ethylene Propylene Diene Monomer FPM= Fluorocarbon PVDF= Polyvinylidene Fluoride
 S= 304SS STZP= Steel/Zinc Plated

MAINTENANCE

⚠ WARNING

Before commencing with service, shut-off drive (electric motor, gas or diesel engine) and turn off water supply to pump. Relieve all discharge line pressure by triggering gun or opening valve in discharge line.

Diaphragm Disassembly

1. Use a 5 mm allen wrench to remove four (4) hex socket head cap screws (HSH) from pump body.
2. Separate pump body from diaphragm body.
3. Remove diaphragm and then spacer by hand.
4. Inspect diaphragm and spacer for wear or damage, and replace as needed.

Diaphragm Disassembly

1. Insert crosshatched side of spacer into pump body.
2. Insert diaphragm with the open end into pump body.
3. Align four (4) holes in pump body with holes of diaphragm body.
4. Hand thread in four (4) HSH screws.
5. Use a 5 mm allen wrench to tighten screws, ensure bodies are drawn up evenly. Torque to 144 in-lbs, 12 ft-lbs or 16 N-m

Note: Discharge port can be orientated in 90° increments by removing the four hex socket head cap screws with a 5mm allen wrench and rotating body to desired location. Re-torque to 12 ft-lbs.

Valve Disassembly (Discharge/Inlet)

1. Use a 19 mm open-wrench to remove hex head valve plug with O-ring.
2. Inspect valve plug for wear or damage and replace as needed.
3. Inspect valve plug O-ring for cuts or wear and replace as needed (replacement O-ring can be found in valve kit).
4. Insert an M8 bolt into the "IN" port and thread into the inlet valve seat. Tap with rubber hammer to push the complete valve assembly through the "OUT" port. Remove M8 bolt.
5. Separate discharge valve assembly (top) from inlet valve assembly (bottom).
6. Disassemble both discharge valve and inlet valve assemblies.
7. Inspect all seats, valves and springs for grooves, pitting or wear and replace with a new valve kit as needed.
8. Inspect all O-rings for cuts or wear and replace with a new valve kit as needed.

Valve Reassembly (Discharge/Inlet)

Note: New stacked valve assembly (discharge/inlet) comes preassembled.

1. Lubricate both discharge and inlet valve seat O-rings.
2. Place new stacked valve assembly with inlet valve seat facing into valve chamber.
3. To ensure that the valve assembly is properly seated, use a socket that closely matches the webbing on the discharge valve retainer and press into place. Do not force in.
4. Install new O-ring onto valve plug and lubricate.
5. Apply Loctite® 242® to threads of valve plug, hand thread valve plug into valve chamber.
6. Use a 19 mm open-wrench to torque to 516 in-lbs, 43 ft-lbs or 58 N-m.

Loctite and 242 are registered trademarks of the Henkel Corporation.

TROUBLESHOOTING

PROBLEM	PROBABLE CAUSE	SOLUTION
No chemical supply from pulse pump	High inlet pressure on main pump	Adjust inlet pressure to maximum 5 psi
	Air in chemical supply	Remove air in chemical supply
	Debris in inlet or discharge valves of drive pump	Remove debris
	Debris in inlet or discharge valves of pulse pump	Remove debris
	Not primed properly	Properly prime system
Limited chemical supply from pulse pump	Worn inlet discharge valves	Replace worn inlet and discharge valves
	Restriction in metering hose	Remove restriction in metering hose
	Restriction between drive pump and pulse pump	Remove restriction between drive pump and pulse pump

⚠ CAUTIONS AND WARNINGS

All high-pressure systems require a primary pressure regulating device (e.g. regulator, unloader) and a secondary pressure relief device (e.g. pop-off valve, relief valve). Failure to install such relief devices could result in personal injury or damage to pump or property. Cat Pumps does not assume any liability or responsibility for the operation of a customer's high-pressure system.

Read all CAUTIONS and WARNINGS before commencing service or operation of any high-pressure system. The CAUTIONS and WARNINGS are included in each Service Manual and with each Accessory Data sheet. CAUTIONS and WARNINGS can also be viewed online at www.catpumps.com/dynamic-literature/cautions-and-warnings or can be requested directly from Cat Pumps.

WARRANTY

View the Limited Warranty online at www.catpumps.com/literature/cat-pumps-limited-warranty