

DATA SHEET

8 FRAME BLOCK-STYLE PLUNGER PUMPS



Stainless Steel Flushed Models: **781KM, 784KM**



Model 781KM Shown
(Mounting rails sold separately)

FEATURES

- Triplex plunger design ensures high efficiency and low pulsation.
- Durable V-packings are lubricated and cooled by the liquid being pumped.
- Models 781KM and 784KM offer an external flush for high-temperature or low-lubricity fluids.
- Belt-driven option provides precise flow settings.
- Direct-drive option offers a compact foot print for electric motors with a NEMA or IEC frame, or SAE hydraulic motors with a bell housing/flexible coupler assembly.
- Pump comes standard with NBR seals. Alternative seal materials are available for higher temperature or chemical compatibility.

SPECIFICATIONS	U.S. Measure	Metric Measure
Flow (781KM)	4.7 gpm	17.8 lpm
Flow (784KM)	2.9 gpm	11.0 lpm
Pressure Range	100–5000 psi	6.9–345 bar
Pump RPM*	1750 rpm	1750 rpm
Inlet Pressure Range	Flooded to 800 psi	Flooded to 55 bar
Max. Liquid Temp. (NBR)	160° F	71° C

Alternate seals available for higher temperatures up to 200° F

Bore	0.551"	14 mm
Stroke (Model 781KM)	0.945"	24 mm
Stroke (Model 784KM)	0.591"	15 mm
Crankcase Capacity	25 oz	0.74 l
Inlet Ports (2)	½" NPT(F)	½" NPT(F)
Flushing Ports (2)	⅛" NPT(F)	⅛" NPT(F)
Discharge Port (2)	⅜" NPT(F)	⅜" NPT(F)
Shaft Diameter – Single End	0.945"	24 mm
Weight	48.1 lbs	21.8 kg
Dimensions (Model 781KM)	13.15 x 9.25 x 6.06"	334 x 235 x 154 mm
Dimensions (Model 784KM)	13.15 x 7.92 x 6.06"	334 x 201 x 154 mm

*Pump minimum is 100 RPM.

ALTERNATIVE SEAL CONFIGURATION

MATERIAL	SUFFIX CODE	MAXIMUM TEMPERATURE	
NBR	—	160° F	(71° C)
FPM	.0110	180° F	(82° C)
EPDM	.0220	160° F	(71° C)
FFKM	.0770	200° F	(93° C)
HT	.3000	180° F	(82° C)
STHT	.3400	190° F	(88° C)

See **Tech Bulletin 002** for inlet conditions and RPM at high temperature.

$$\frac{\text{Rated gpm}}{\text{Rated rpm}} = \frac{\text{Desired gpm}}{\text{Desired rpm}}$$

$$\frac{\text{hp}}{\text{(Electric Brake)}} = \frac{\text{gpm} \times \text{psi}}{1460}$$

$$\frac{\text{Motor Pulley OD}}{\text{Pump rpm}} = \frac{\text{Pump Pulley OD}}{\text{Motor rpm}}$$

Refer to pump **Service Manual** for repair procedure and additional technical information.

PARTS LIST

ITEM	PART NUMBER	MATL	PART NUMBER	MATL	DESCRIPTION	QTY
	781KM		784KM			
5	92538	S	92538	S	Screw, HHC, Sems (M6 x 16)	8
8	133571	ALE	133571	ALE	Cover, Bearing	1
9	815280	FBR	815280	FBR	Shim, Split, 2-Piece	1-2
10	12393	NBR	12393	NBR	O-Ring, Bearing Cover	2
11	43222	NBR	43222	NBR	Seal, Oil, Crankshaft	1
15	43221	STL	43221	STL	Bearing, Roller	2
20	768863	TNM	768863	TNM	Rod Assembly, Connecting (See Tech Bulletin 074)	3
25	119234	FCM	—	—	Crankshaft, Single-End (M24 with 60 mm Extension) (Model 781KM)	1
	—	—	44591	FCM	Crankshaft, Single-End (M15 with 34 mm Extension) (Model 784KM)	1
30	133572	ALE	133572	ALE	Cover, Blind Bearing	1
32	44666	RTP	44666	RTP	Cap, Oil Filler, Domed	1
33	14177	NBR	14177	NBR	O-Ring, Filler Cap-70D	1
37	92241	PC	92241	PC	Gauge, Oil, Bubble with Gasket-80D (See Tech Bulletin 074)	1
38	44428	NBR	44428	NBR	Gasket, Flat, Oil Gauge-80D	1
40	92538	S	92538	S	Screw, HHC, Sems (M6 x 16) (See Tech Bulletin 074)	4
48	25625	STCP	25625	STCP	Plug, Drain (1/4" x 19 BSP)	1
49	23170	NBR	23170	NBR	O-Ring, Drain Plug-70D	1
50	133569	ALE	133569	ALE	Cover, Rear	1
51	14047	NBR	14047	NBR	O-Ring, Rear Cover-70D	1
53	133593	ALE	133593	ALE	Crankcase with Guide Pins	1
54	27488	S	27488	S	Pin, Guide	2
64	763237	SS	763237	SS	Pin, Crosshead	3
65	768913	AL	768913	AL	Rod, Plunger	3
69	126589	STCP R	126589	STCP R	Washer, Oil Seal	3
70	43228	NBR	43228	NBR	Seal, Oil, Crankcase	3
75	43328	S	43328	S	Slinger, Barrier	3
88	45697	S	45697	S	Washer, Keyhole (M18 x M10)	3
90	45890	CC	45890	CC	Plunger (M14 x 72)	3
95	89653	SS	89653	SS	Stud, Plunger Retainer (M6 x 58)	3
96	43235	PTFE	43235	PTFE	Backup Ring, Plunger Retainer	3
97	17399	NBR	17399	NBR	O-Ring, Plunger Retainer-80D	3
98	44041	SS	44041	SS	Gasket, Plunger Retainer	3
99	49665	SS	49665	SS	Retainer, Plunger (M6) (See Tech Bulletin 074)	3
100	995686	PVDF	995686	PVDF	Retainer, Seal (See Tech Bulletin 105)	3
104	701734	NBR	701734	NBR	O-Ring, Inlet Adapter-70D	3
105	701587	SS	701587	SS	Adapter, Inlet	3
106	48821	NBR	48821	NBR	Seal, Low-Pressure with SS-Spring	3
110	49241	SS	49241	SS	Manifold, Inlet/Discharge, Block-Style Flushed (1/8" Flushed Port)	1
112	701595	NBR	701595	NBR	O-Ring, V-Packing Spacer-70D	3
117	87952	S	87952	S	Screw, HSH (M10 x 55) (See Tech Bulletin 074)	4
122	701598	PTFE	701598	PTFE	Backup Ring, V-Packing Cylinder	3
123	701596	NBR	701596	NBR	O-Ring, V-Packing Cylinder-70D	3
124	701589	SS	701589	SS	Cylinder V-Packing	3
126	701682	SS	701682	SS	Adapter, Female	3
127	45895	SNG	45895	SNG	V-Packing	9
128	701683	SS	701683	SS	Adapter, Male	3
162	701599	PTFE	701599	PTFE	Backup Ring, Valve Seat	12
163	701597	NBR	701597	NBR	O-Ring, Seat-70D	12
164	701591	SS	701591	SS	Seat	6
166	701751	SS	701751	SS	Valve	6
167	44056	SS	44056	SS	Spring	6
168	44565	PVDF	44565	PVDF	Retainer, Spring	6
185	49213	SS	49213	SS	Manifold, Valve, Block-Style (Includes: Inserts, Valve Plugs)	1
188	87952	S	87952	S	Screw, HSH, (M10 x 55) (See Tech Bulletin 074)	14

Bold print numbers are unique to a particular pump model. Italics are optional items.

R Components comply with RoHS Directive. For additional technical information see www.catpumps.com/literature/tech-bulletins.
MATERIAL CODES (Not Part of Part Number): AL=Aluminum ALE=Aluminum Epoxy CC=Ceramic CM=Chrome-Moly EPDM=Ethylene Propylene Diene Monomer
FBR=Fiber FCM=Forged Chrome-Moly FFKM=Perfluoroelastomer FPM=Fluorocarbon NBR=Medium Nitrile (Buna-N) PC=Poly Carbonate PE=Polyethylene
PTFE=Pure Polytetrafluoroethylene PVDF=Polyvinylidene Fluoride RTP=Reinforced Composite S=304SS SFTA=Special Blend PTFE Tan
SNG=Special Blend (Buna) SS=316SS ST4=Special PTFE4 STCP=Steel/Chrome Plated STL=Steel
STZP=Steel/Zinc Plated TNM=Special High Strength

EXPLODED VIEW

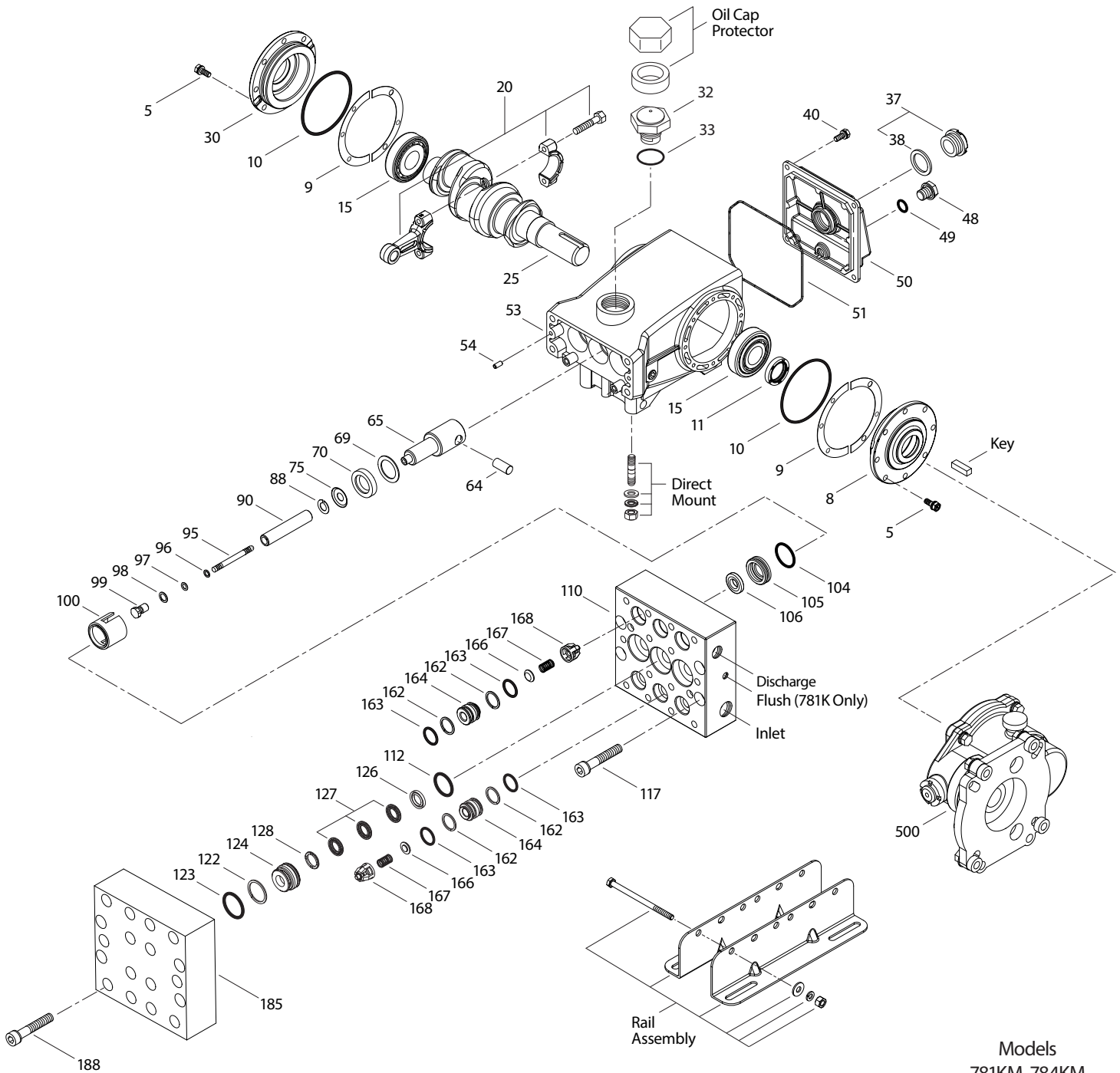

Models
781KM, 784KM
November 2024

OPTIONAL PARTS AND ACCESSORIES

PART	DESCRIPTION	QTY
30067	Key (M8 x 7.5 x 25)	1
30660	Kit, Complete Mounting	1
30611	Assembly, Rail (4.22" See Dimensional Drawing)	1
30645	Assembly, Rail (5.02" See Dimensional Drawing)	1
30243	Mount, Direct	1
828710	Protector, Oil Cap	1
34334	Kit, Oil Drain (3/8" x 24") (Not Shown)	1

SERVICE PARTS

PART	DESCRIPTION	QTY
701883	Seal Kit-Standard NBR	1
701884	Valve Kit-Standard NBR	2
6107	Oil, Bottle (21 oz) (Fill to Specified Crankcase Capacity Prior to Start-up)	2
6139	Lubricant, Anti-Seize (8 oz)	1
30696	Reverse Plier	1
811485	Head, Complete with NBR Seals and O-Rings	1

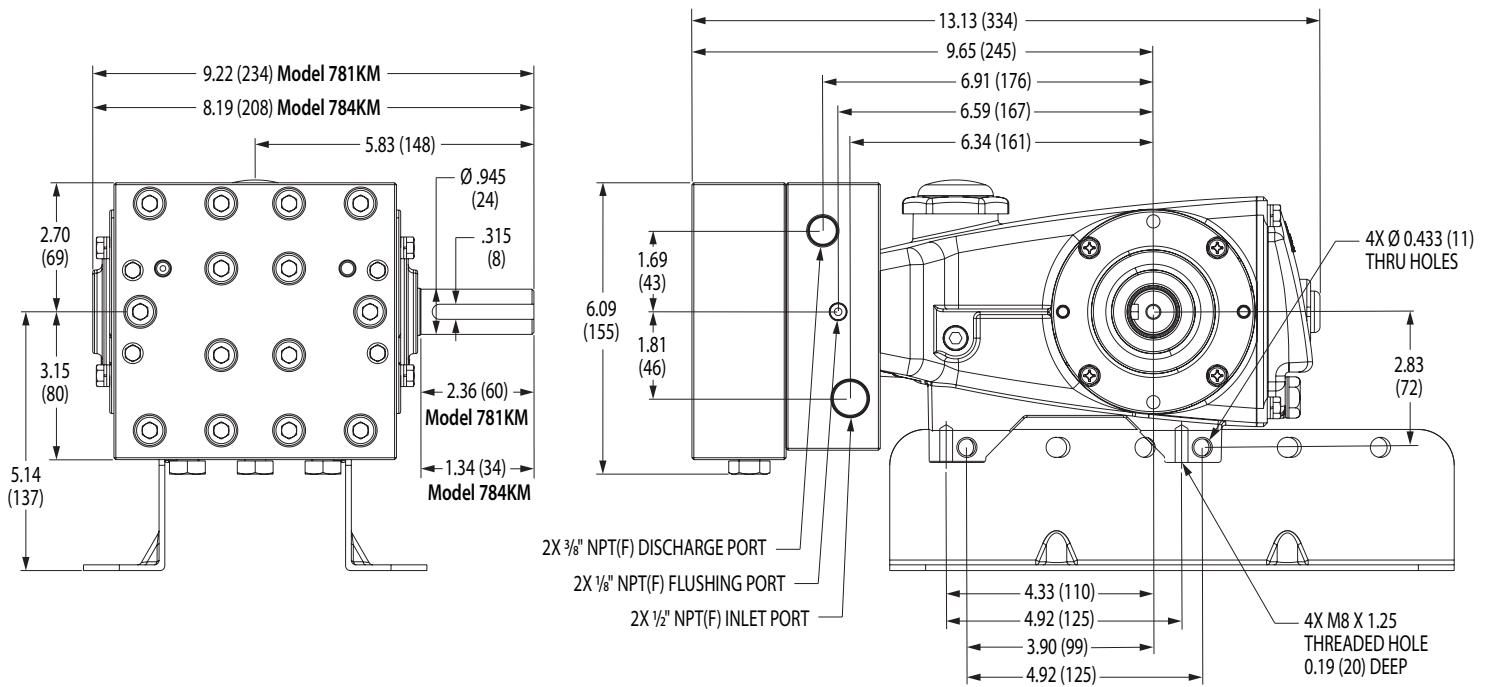

Models 781KM, 784KM

SEAL KITS One (1) seal kit required per pump

PUMP MODELS	NBR (STD)	FPM (.0110)	EPDM (.0220) ♦	FFKM (.0770)	HT (.3000)	STHT (.3400)
781KM, 784KM	701883	701920*	76883*	702843*	701885*	76286*

ITEM (Included in Seal Kits)							DESCRIPTION	QTY
96	43235	43235	43235	43235	48235	48235	Backup Ring, Plunger Retainer	3
97	17399	14160	46204	701715	17399	17399	O-Ring, Plunger Retainer	3
104	701734	701912	703297	702774	701734	701734	O-Ring, Inlet Adapter	3
106	48821 ¹	704649 ²	49466 ¹	704649 ²	48821 ¹	704649 ²	Seal, Low-Pressure	3
112	701595	701913	703298	702496	701595	701595	O-Ring, V-Packing Spacer	3
122	701598	701598	701598	701598	701598	701598	Backup Ring, V-Packing Cylinder	3
123	701596	701914	703318	702769	701596	701596	O-Ring, V-Packing Cylinder	3
127	45895	704666	704666	701791	704666	704666	V-Packing	9

♦ Silicone oil/grease required *Review material codes for individual items (SFTA, SNG, ST4 may be used as alternative)

1= 316SS Spring

2= NIH Spring

VALVE KITS Two (2) valve kits required per pump

PUMP MODELS	NBR (STD)	FPM (.0110)	EPDM (.0220) ♦	FFKM (.0770)	HT (.3000)	STHT (.3400)
781KM, 784KM	701884	701921	76884	702844	701884	701884

ITEM (Included in Valve Kits)							DESCRIPTION	QTY
162	701599	701599	701599	701599	701599	701599	Backup Ring, Valve Seat	6
163	701597	701915	703180	702495	701597	701597	O-Ring, Valve Seat	6
164	701591	701591	701591	701591	701591	701591	Seat	3
166	701751	701751	701751	701751	701751	701751	Valve	3
167	44056	44056	44056	44056	44056	44056	Spring	3
168	44565	44565	44565	44565	44565	44565	Retainer, Spring	3

♦ Silicone oil/grease required

⚠ CAUTIONS AND WARNINGS

All high-pressure systems require a primary pressure regulating device (e.g. regulator, unloader) and a secondary pressure relief device (e.g. pop-off valve, relief valve). Failure to install such relief devices could result in personal injury or damage to pump or property. Cat Pumps does not assume any liability or responsibility for the operation of a customer's high-pressure system.

Read all CAUTIONS and WARNINGS before commencing service or operation of any high-pressure system. The CAUTIONS and WARNINGS are included in each Service Manual and with each Accessory Data sheet. CAUTIONS and WARNINGS can also be viewed online at www.catpumps.com/dynamic-literature/cautions-and-warnings or can be requested directly from Cat Pumps.

WARRANTY

View the Limited Warranty online at www.catpumps.com/literature/cat-pumps-limited-warranty