

DATA SHEET

7 FRAME PLUNGER PUMPS



Brass Models: 57, 60

Gearbox Models: 60G1, 60G118

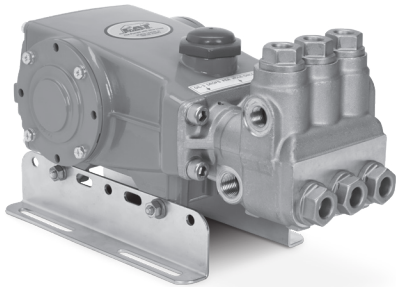

Model 60 Shown
(Rails Sold Separately)

FEATURES

- Triplex plunger design ensures high efficiency and low pulsation.
- Durable V-packings are lubricated and cooled by the liquid being pumped.
- Belt-driven option provides precise flow settings.
- Direct-drive option offers a compact foot print for electric motors with a NEMA or IEC frame, or SAE hydraulic motors with a bell housing/flexible coupler assembly.
- Gearbox model available with 1" and 1½" hollow shaft to fit a wide variety of engines.
- Pump comes standard with NBR seals. Alternative seal materials are available for higher temperature or chemical compatibility.

COMMON

SPECIFICATIONS	U.S.	Metric
Inlet Pressure Range	Flooded to 60 psi	Flooded to 4.1 bar
Max. Liquid Temperature (NBR)	160° F	71° C
Alternative seals available for higher temperature up to 190° F		
Bore	0.709"	18 mm
Crankcase Capacity	25 oz	0.74 l
Inlet Ports (2)	½" NPT(F)	½" NPT (F)
Discharge Ports (2)	¾" NPT (F)	¾" NPT (F)
Shaft Diameter	0.945"	24 mm
Weight	28.7 lbs	13 kg
Dimensions	13.90 x 8.19 x 6.38"	354 x 208 x 162 mm

SPECIFICATIONS

U.S. Measure

Metric Measure

Model 57

Flow	4.5 gpm	17 lpm
Pressure Range	100–4000 psi	6.9–276 bar
Pump RPM*	1285 rpm	1285 rpm
Stroke	0.728"	18.5 mm

Model 60

Flow	4.7 gpm	17.9 lpm
Pressure Range	100–4000 psi	6.9–276 bar
Pump RPM*	1750 rpm	1750 rpm
Stroke	0.591"	15 mm

Gearbox Models 60G1, 60G118

Flow	4.5 gpm	17 lpm
Pressure Range	100–4000 psi	6.9–276 bar
Engine RPM	3450 rpm	3450 rpm
Stroke	0.591"	15 mm

*Pump minimum is 100 rpm.

ALTERNATIVE SEAL CONFIGURATION

MATERIAL	SUFFIX CODE	MAXIMUM TEMPERATURE	
NBR	—	160° F	(71° C)
FPM	.0110	180° F	(82° C)
EPDM	.0220	160° F	(71° C)
HT	.3000	180° F	(82° C)
STHT	.3400	190° F	(88° C)

See **Tech Bulletin 002** for inlet conditions and RPM at high temperature.

$$\text{DETERMINING THE PUMP RPM} \quad \frac{\text{Rated gpm}}{\text{Rated rpm}} = \frac{\text{Desired gpm}}{\text{Desired rpm}}$$

$$\text{DETERMINING THE REQUIRED HP} \quad \frac{\text{Hp (Electric Brake)}}{1460} = \frac{\text{gpm} \times \text{psi}}{1460}$$

$$\text{DETERMINING MOTOR PULLEY SIZE} \quad \frac{\text{Motor Pulley OD}}{\text{Pump rpm}} = \frac{\text{Pump Pulley OD}}{\text{Motor rpm}}$$

Refer to pump **Service Manual** for repair procedure and additional technical information.

PARTS LIST

DESCRIPTION

ITEM	57	MATL	60/60G1/ 60G118	MATL	DESCRIPTION	QTY
5	125824	STCP R	125824	STCP R	Screw, HHC Sems (M6x16) (See Tech Bulletin 074)	8
8	133571	ALE	133571	ALE	Cover, Bearing	1
9	815280	FBR	815280	FBR	Shim, Split, 2-Piece	2-4
10	12393	NBR	12393	NBR	O-Ring, Bearing Cover	2
11	43222	NBR	43222	NBR	Seal, Oil Crankshaft	1
15	43221	STL	43221	STL	Bearing, Roller	2
20	48863	TNM	48863	TNM	Rod, Connecting (See Tech Bulletin 074)	3
25	44947	FCM	44591	FCM	Crankshaft, Single-End	1
30	133572	ALE	133572	ALE	Cover, Bearing, Blind	1
32	44666	RTP	44666	RTP	Cap, Oil Filler, Domed	1
33	14177	NBR	14177	NBR	O-Ring, Oil Filler Cap-70D	1
37	92241	PC	92241	PC	Gauge, Oil Bubble with Gasket-80D	1
38	44428	NBR	44428	NBR	Gasket, Flat, Oil Gauge-80D	1
40	126541	STCP R	126541	STCP R	Screw, HHC Sems (M6 x 20) (See Tech Bulletin 074)	4
48	25625	STCP	25625	STCP	Plug, Drain (1/4" x 19 BSP)	1
49	23170	NBR	23170	NBR	O-Ring, Drain Plug-70D	1
50	133569	ALE	133569	ALE	Cover, Rear	1
51	14047	NBR	14047	NBR	O-Ring, Rear Cover	1
53	133593	ALE	133593	ALE	Crankcase	1
56	43240	POP	43240	POP	Pan, Oil	1
64	43237	CM	43237	CM	Pin, Crosshead	3
65	48913	SHS	48913	SHS	Rod, Plunger, Short	3
69	126589	STCP R	126589	STCP R	Washer, Oil Seal	3
70	43228	NBR	43228	NBR	Seal, Oil, Crankcase	3
75	43328	S	43328	S	Slinger, Barrier	3
88	45697	S	45697	S	Washer, Keyhole (M18 x M10)	3
90	43232	CC	43232	CC	Plunger (M18 x 77)	3
95	126559	STCP R	126559	STCP R	Stud, Plunger Retainer (M6 x 70)	3
96	43235	PTFE	43235	PTFE	Backup Ring, Plunger Retainer	3
97	17399	NBR	17399	NBR	O-Ring, Plunger Retainer-80D	3
98	45891	CU	45891	CU	Gasket, Plunger Retainer	3
99	46504	S	46504	S	Retainer, Plunger (M6) (See Tech Bulletin 074)	3
100	45689	PVDF	45689	PVDF	Retainer, Seal, 2-Piece	3
101	43239	FBR	43239	FBR	Wick, Long Tab	3
106	43243	NBR	43243	NBR	Seal, Low-Pressure with S-Spring	3
120	45685	BB	45685	BB	Case, Seal (See Tech Bulletin 074)	3
121	20285	NBR	20285	NBR	O-Ring, Seal Case-70D	3
126	44550	BB	44550	BB	Adapter, Female	3
127	44549	SNG	44549	SNG	V-Packing	6
128	45618	BB	45618	BB	Adapter, Male	3
162	43248	PTFE	43248	PTFE	Backup Ring, Seat	6
163	43249	NBR	43249	NBR	O-Ring, Seat-80D	6
164	43722	S	43722	S	Seat	6
166	43721	S	43721	S	Valve	6
167	43751	S	43751	S	Spring	6
168	44564	PVDF	44564	PVDF	Retainer, Spring	6
172	14179	NBR	14179	NBR	O-Ring, Valve Plug-70D	6
173	20213	PTFE	20213	PTFE	Backup Ring, Valve Plug	6
174	45939	BB	45939	BB	Plug, Valve, Extended (See Tech Bulletin 074)	6
185	45937	FBB	45937	FBB	Head, Manifold, (M10)	1
186	49680	S	49680	S	Washer, Spring (M10)	4
188	49679	S	49679	S	Screw, HSH (M10 x 35) (See Tech Bulletin 074)	4
500	—	—	8071	—	Gearbox - 1" Shaft (See individual Data Sheet) (Model 60G1)	1
	—	—	8078	—	Gearbox - 1 1/8" Shaft (See individual Data Sheet) (Model 60G118)	1

Bold print part numbers are unique to a particular pump model.

R Components comply with RoHS Directive. For additional technical information see www.catpumps.com/literature/tech-bulletins.

MATERIAL CODES (Not Part of Part Number): ALE=Aluminum Epoxy BB=Brass CC=Ceramic CM=Chrome-Moly CU=Copper FBB=Forged Brass
 FBR=Fiber FCM=Forged Chrome-Moly FPM=Fluorocarbon HT=High Temp NBR=Medium Nitrile (Buna-N) PC=Poly Carbonate PE=Polyethylene
 POP=Polypropylene PTFE=Pure Polytetrafluoroethylene PVDF=Polyvinylidene Fluoride RTP=Reinforced Composite S=304SS SFG=Special Blend FPM
 SHS=304SS/High Strength SNG=Special Blend (Buna) ST2=Special PTFE2 STCP=Steel/Chrome Plated STG=Special Blend PTFE White
 STHT=Special PTFE High Strength STL=Steel STZP=Steel/Zinc Plated TNM=Special High Strength

Optional Parts and Accessories and Service Parts listed on page 3. Standard and Optional Seal and Valve Kits listed on page 4.

EXPLODED VIEW

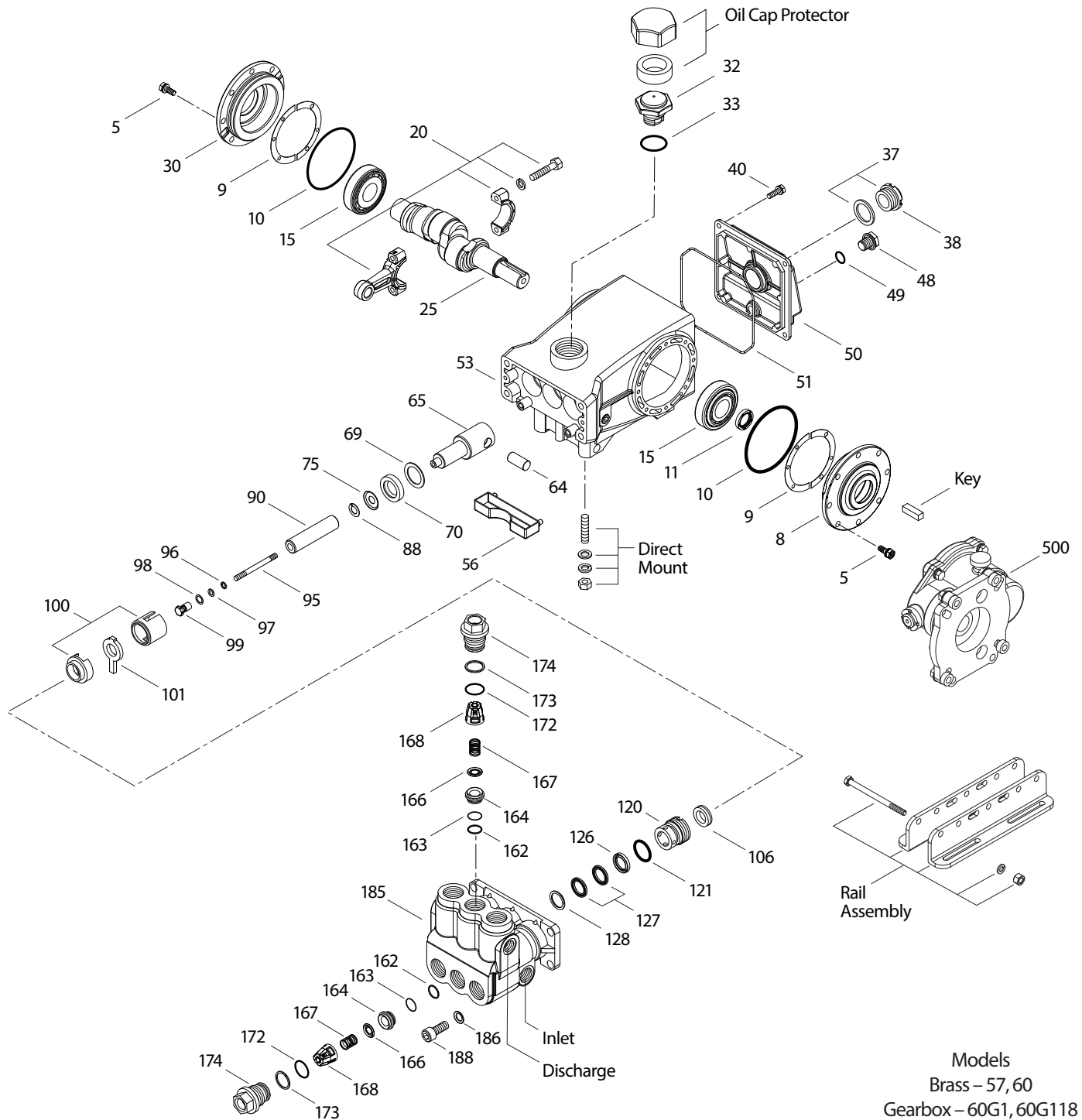

Models
 Brass – 57, 60
 Gearbox – 60G1, 60G118
 November 2024

OPTIONAL PARTS AND ACCESSORIES

PART	DESCRIPTION	QTY
30067	Key (M8 x 7.25 x 25)	1
30611	Assembly, Rail (4.63" See Dimensional Drawing)	1
30645	Assembly, Rail (5.42" See Dimensional Drawing)	1
76513	Assembly, Rail (5.92" See Dimensional Drawing)	1
30243	Mount, Direct	1
828710	Protector, Oil Cap	1
34334	Kit, Oil Drain (3/8" x 24") (Not Shown)	1

SERVICE PARTS

PART	DESCRIPTION	QTY
30799	Kit, Seal – Standard NBR	1
33820	Kit, Valve – Standard NBR	2
6107	Oil, Bottle (21 oz) ISO 68 Hydraulic (Fill to Specified Crankcase Capacity Prior to Start-up)	1-2
6124	Gasket, Liquid (3 oz)	1
30696	Reverse Pliers (Not Shown)	1
33005	Socket, Seal Case (1/2" Drive) (Not Shown)	1
814618	Head, Complete with NBR Seals and O-Rings	1

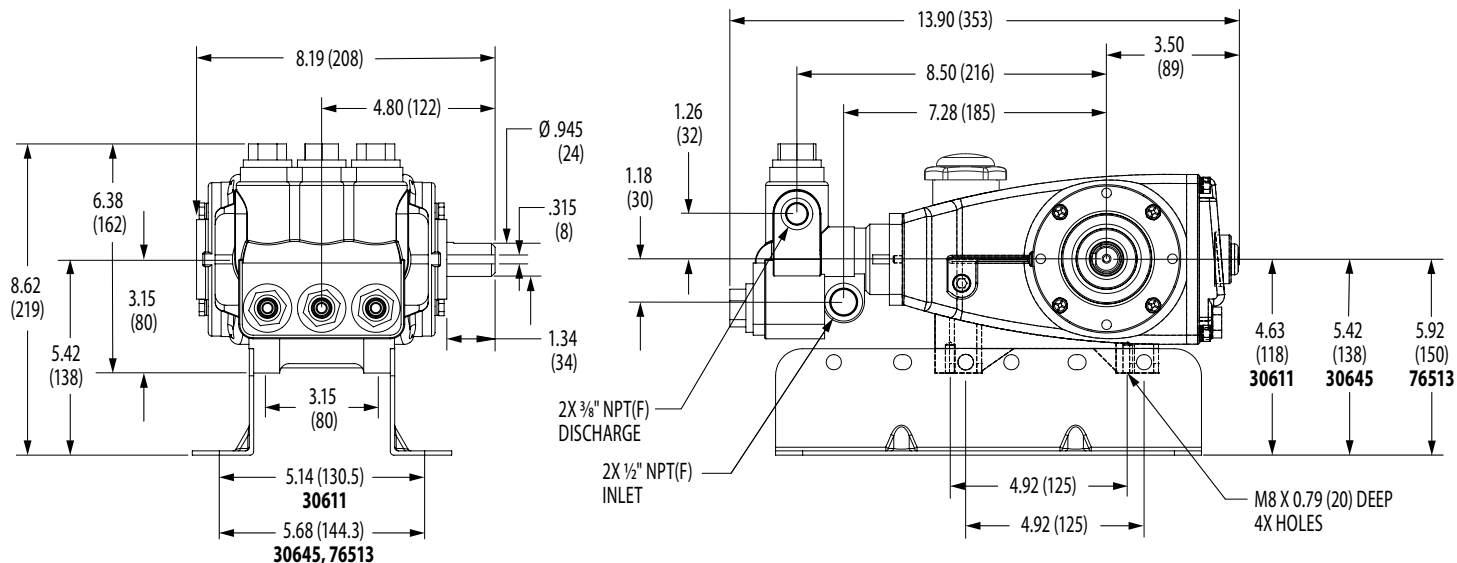

Models 57, 60

SEAL KITS One (1) seal kit required per pump

PUMP MODELS	NBR (STD)	FPM (.0110)	HT (.3000)	STHT (.3400)
57, 60, 60G1, 60G118	30799	34237	76799	76826

ITEM (Included in Seal Kits)					DESCRIPTION	QTY
97	17399	14160	17399	17399	O-Ring, Plunger Retainer	3
101	43239	43239	43239	43239	Wick, Long Tab	3
106	43243		43243	76243	Seal, Low-Pressure with S-Spring	3
		44926			Seal, Low-Pressure with SS-Spring	3
121	20285	11693	20285	20285	O-Ring, Seal Case	3
127	44549	45617	48300	48300	V-Packing	6

VALVE KITS Two (2) valve kits required per pump

PUMP MODELS	NBR (STD)	FPM (.0110)	HT (.3000)	STHT (.3400)
57, 60, 60G1, 60G118	33820	34238	33820	33820

ITEM (Included in Valve Kits)					DESCRIPTION	QTY
163	43248	43248	43248	43248	Backup Ring, Seat	3
164	43249	44383	43249	43249	O-Ring, Seat	3
166	43722	43722	43722	43722	Seat	3
167	43721	43721	43721	43721	Valve	3
168	43751	43751	43751	43751	Spring	3
172	44564	44564	44564	44564	Retainer, Spring	3
173	14179	15855	14179	14179	O-Ring, Valve Plug	3
173	20213	20213	20213	20213	Backup Ring, Valve Plug	3

CAUTIONS AND WARNINGS

All high-pressure systems require a primary pressure regulating device (e.g. regulator, unloader) and a secondary pressure relief device (e.g. pop-off valve, relief valve). Failure to install such relief devices could result in personal injury or damage to pump or property. Cat Pumps does not assume any liability or responsibility for the operation of a customer's high-pressure system. Read all CAUTIONS and WARNINGS before commencing service or operation of any high-pressure system. The CAUTIONS and WARNINGS are included in each Service Manual and with each Accessory Data sheet. CAUTIONS and WARNINGS can also be viewed online at www.catpumps.com/dynamic-literature/cautions-and-warnings or can be requested directly from Cat Pumps.

WARRANTY

View the Limited Warranty online at www.catpumps.com/literature/cat-pumps-limited-warranty