

DATA SHEET

HIGH-PRESSURE RELIEF VALVES



Stainless Steel Models: **7034, 7036, 7037**



(Model 7034 shown)

FEATURES

- Provides system pressure control and protection for single or multiple gun and pump systems.
- Maintains full system pressure while running in bypass with minimal load on pump.
- Lightweight, compact design quickly and conveniently mounts directly into discharge line.
- 316 Stainless Steel construction delivers strength and corrosion resistance.
- FPM elastomers.

SPECIFICATIONS	U.S. Measure	Metric Measure
7034 (White Spring)		
Pressure Range	218–2175 psi	15–150 bar
Maximum Relief Setting	2392 psi	165 bar
7036 (Blue Spring)		
Pressure Range	406–4060 psi	28–280 bar
Maximum Relief Setting	4466 psi	308 bar
7037 (Black Spring)		
Pressure Range	580–5800 psi	40–400 bar
Maximum Relief Setting	6380 psi	440 bar

Use only at above specifications to ensure proper regulator life and performance.

COMMON SPECIFICATIONS

	U.S.	Metric
Flow Range	0–21 gpm	0–80 lpm
Maximum Temperatures (FPM)	180° F	82° C
Inlet Ports (2)	½" NPT(F)	½" NPT(F)
Discharge Port	½" NPT(F)	½" NPT(F)
Bypass Port	½" NPT(F)	½" NPT(F)
Weight	2.7 lbs	1.22 kg
Dimensions	8.21 x 3.78 x 1.85"	208 x 96 x 47 mm

ALTERNATIVE O-RING CONFIGURATION

MATERIAL	SUFFIX CODE	MAXIMUM TEMPERATURE	
FPM	—	180° F	(82° C)
EPDM	.0220	160° F	(71° C)
NBR	.0330	140° F	(60° C)
IPFE	.0770	240° F	(115° C)

Read all CAUTIONS and WARNINGS before commencing service or operation of any high-pressure system

SELECTION

Select a relief valve to meet or exceed the flow and pressure requirements of the system. This valve is to be used as a secondary pressure control device and does not replace a primary pressure control device like a regulator or unloader.

INSTALLATION

The relief valve should mount to the pump manifold's discharge port opposite the primary pressure control valve. If unavailable, plumb the relief valve parallel to the high-pressure line upstream from the primary pressure control valve.

The inlet connection is a 1/2" NPT(F) port. There are two (2) ports with the word IN and arrows marked on the body, indicating the direction of flow. Liquid from the discharge of the manifold goes into this connection.

The discharge connection is a 1/2" NPT(F) port. There is an arrow and the word OUT marked on the body indicating the direction of flow.

The bypass connection is a 1/2" NPT(F) port. The word BY-PASS is marked on both sides of the body, indicating the flow direction. The bypass flow from the Relief Valve should be left open or drained to the floor. Do not route the bypass flow back to the inlet of the pump.

OPERATION

The primary function of this relief valve is to relieve system pressure and bypass pumped liquid in the event the primary control valve fails.

Note: The relief valve is a secondary pressure control device. It does not replace a primary pressure control device like a pressure regulator or unloader.

PRESSURE ADJUSTMENT

Setting the Primary Pressure Regulating Device

Note: Pressure is not set at the factory

1. Setting and adjusting the primary pressure regulating device and relief valve must be done while the system is running.
2. Start the system with the primary pressure regulating device backed off to the lowest pressure setting (counterclockwise direction) and the relief valve set at the highest pressure setting (clockwise direction).
3. Squeeze the trigger and read the pressure on the gauge at the pump.

Note: Do not read the pressure at the gun or nozzle.

4. If more pressure is desired, release the trigger, adjust primary device by turning in a clockwise direction.
5. Squeeze the trigger and read the pressure.
6. Repeat this process until desired system pressure is attained.

Setting the Relief Valve

1. Use a wrench to turn the nuts on the top of the relief valve in a counterclockwise direction until there is some visible liquid coming out of the bypass port.
2. Turn nuts on the top of the relief valve in a clockwise direction until the visible liquid stops coming out.
3. Final adjustment for the relief valve should relieve at 200 psi above the system operating pressure.

TYPICAL RELIEF VALVE INSTALLATION

1. Pressure Gauge
2. **Relief Valve**
(Secondary Pressure Relief Device)
3. Pressure Regulator
(Primary Pressure Regulating Device)
4. Triplex Plunger Pump

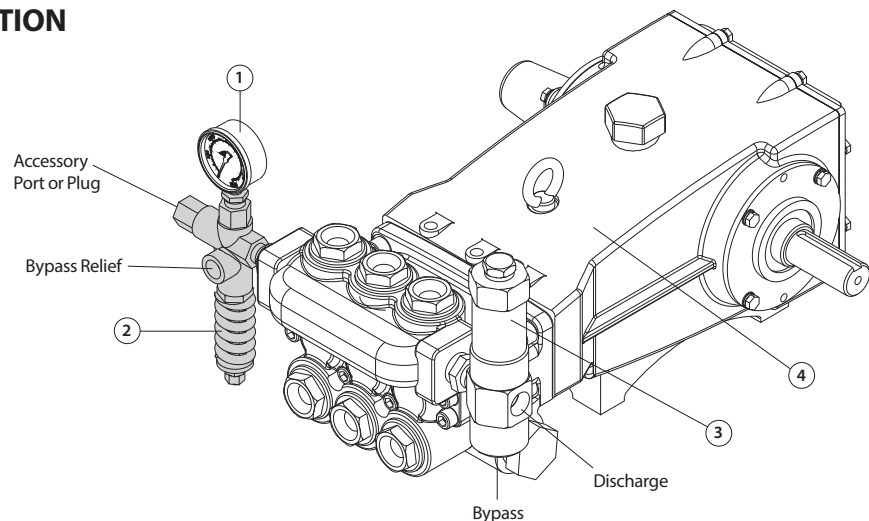

SERVICING

Disassembly:

1. Disconnect bypass and discharge plumbing from relief valve.
2. Remove relief valve from pump and secure in a vise.
3. Remove adjusting nuts, spring retainer and pressure spring from body. Examine pressure spring for fatigue or breaks. Replace as needed.
4. Remove one nut from threaded piston stem.
5. Drive out piston pin from piston retainer.
6. Remove piston retainer with O-ring and backup ring from body. Examine O-ring and backup ring for cuts or wear. Replace as needed.
7. Remove piston stem with O-ring and backup rings from body. Examine O-ring and backup rings for cuts or wear. Replace as needed.
8. Remove inlet fitting with O-ring, spring and ball. Examine O-ring for cuts or wear and replace as needed. Examine spring for fatigue or breaks. Replace as needed.
9. Tap out valve seat with O-ring from the top. Examine O-ring for cuts or wear. Replace as needed.

Note: Inspect sealing areas within the internal body of the relief valve for grooves, pitting and wear. If damage is found, replace with new relief valve. If not, proceed with reassembly.

Reassembly:

1. Lubricate and install O-ring onto seat. Press seat into relief valve body from the bottom port with the chamfered surface facing down.
2. Lubricate and install O-ring onto inlet fitting. Apply anti-seize lubricant (P/N 6139) onto threads of inlet fitting and body. Place spring into recessed port of inlet fitting and then place ball onto spring. Carefully thread inlet fitting with spring and ball into relief valve body.
3. Lubricate and install one O-ring into groove on piston stem. Place one backup ring on each side of the O-ring. Lower piston stem into top port until completely seated.
4. Lubricate and install large O-ring onto outer diameter of piston retainer. Lubricate and install small backup ring, and then small O-ring into hole of threaded end of the piston retainer. Apply anti-seize lubricant (P/N 6139) onto threads of piston retainer and body. Carefully thread piston retainer into relief valve body.

Note: Ensure that the hole in the piston stem aligns with slot on top of piston retainer.

5. Press piston pin through slot in piston retainer and hole in piston stem.
6. Apply Loctite® 609 to threads of one nut and thread onto piston stem. Nut should thread down to last thread on piston stem.

Note: Model 7037 uses 2 lower nuts.

7. Install pressure spring over piston stem, then spring retainer with boss facing down. Thread on hex nut.
8. Reinstall relief valve onto pump.
9. Reconnect bypass and discharge plumbing to pressure relief valve.
10. Proceed to PRESSURE ADJUSTMENT.

Loctite® is a registered trademark of the Henkel Corporation.

TROUBLESHOOTING

Excessive pressure fluctuations	<ul style="list-style-type: none"> • Valve is improperly set Repeat adjustment procedure • Air in system. Check connections
Valve continually bypasses	<ul style="list-style-type: none"> • Seat, ball or piston stem is worn Replace as needed • O-ring seat damaged Replace as needed
Leaking out the top of valve	<ul style="list-style-type: none"> • O-rings on piston stem worn or cut Replace as needed
Pressure spikes	<ul style="list-style-type: none"> • Spring compressed Do not adjust valve for worn nozzles • Restricted bypass or no bypass

PARTS LIST

ITEM	P/N	MATL	DESCRIPTION	QTY
403	30115	S	Nut (M10 x 8)	3
408	32323	STL	Spring, Pressure (White – 7034)	1
	32324	STL	Spring, Pressure (Blue – 7036)	1
	32344	STL	Spring, Pressure (Black – 7037)	1
410	30119	BB	Retainer, Spring	1
412	34586	SS	Stem, Piston with Stellite Tip	1
414	—	PTFE	Backup Ring, Piston	1
415	—	FPM	O-Ring, Piston	1
425	30118	SS	Retainer, Piston	1
426	32326	S	Pin, Piston	1
428	—	FPM	O-Ring, Piston Retainer	1
429	—	FPM	O-Ring, Piston	1
430	—	PTFE	Backup Ring, Piston	2
432	30117	SS	1 $\frac{3}{32}$ " Ball	1
434	30113	SS	Spring, Ball	1
436	34509	SS	Seat	1
437	—	FPM	O-Ring, Seat	1
440	—	SS	Body	1
446	—	FPM	O-Ring, Fitting	1
451	34508	S	Plug (1/2" NPT[M])	1
454	—	FPM	O-Ring, Fitting	1
455	34578	SS	Fitting, Inlet (1/2" NPT[F])	1
460	34580	SS	Fitting, Discharge (1/2" NPT[F])	1
468	30166	FPM	<i>Kit, O-Ring (Standard)</i> <i>(Includes: 414, 415, 428–430, 437, 446, 454)</i>	1
	76066	EPDM	<i>Kit, O-Ring (.0220)</i> <i>(Includes: 414, 415, 428–430, 437, 446, 454)</i>	1
	32346	NBR	<i>Kit, O-Ring (.0330)</i> <i>(Includes: 414, 415, 428–430, 437, 446, 454)</i>	1
	76166	IPFE	<i>Kit, O-Ring (.0770)</i> <i>(Includes: 414, 415, 428–430, 437, 446, 454)</i>	1

Italics are optional items.

Bold print part numbers are unique to a particular model

MATERIAL CODES (Not Part of Part Number):

BB=Brass EPDM=Ethylene Propylene Diene Monomer FPM=Fluorocarbon
IPFE=I-Perfluoroelastomer NBR=Medium Nitrile (Buna-N)
PTFE=Pure Polytetrafluoroethylene S=304SS
SS=316SS STL=Steel

*Models 7034, 7036 use 1 lower nut and 2 upper nuts.
Model 7037 uses 2 lower nuts and 1 upper nut.

EXPLODED VIEW

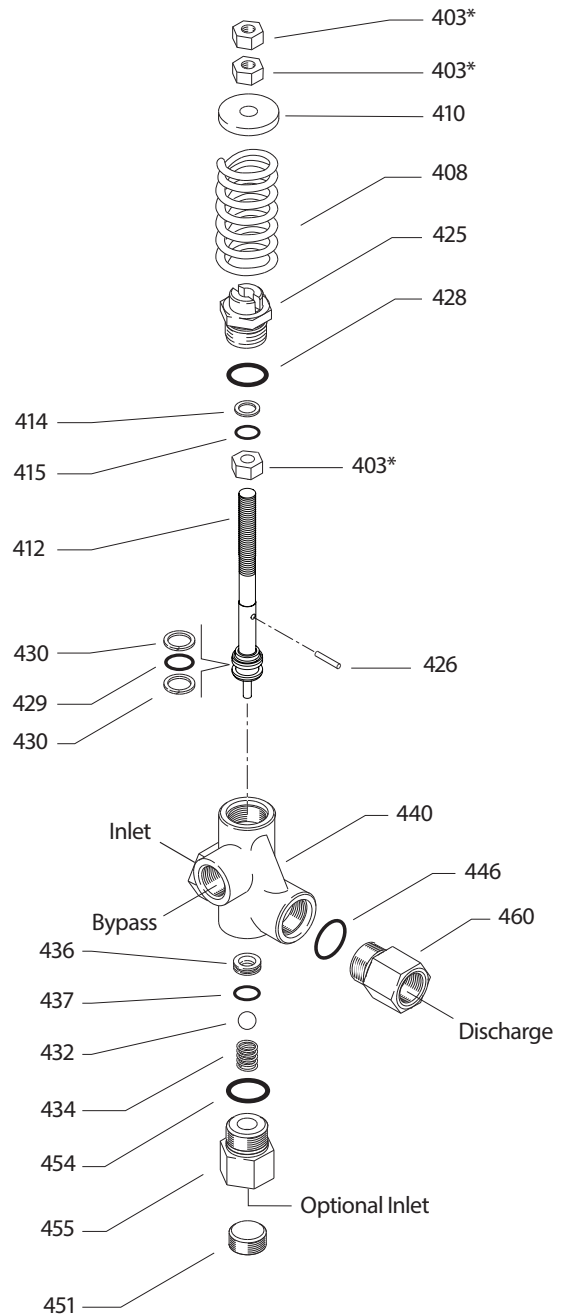

⚠ CAUTIONS AND WARNINGS

All high-pressure systems require a primary pressure regulating device (e.g. regulator, unloader) and a secondary pressure relief device (e.g. pop-off valve, relief valve). Failure to install such relief devices could result in personal injury or damage to pump or property. Cat Pumps does not assume any liability or responsibility for the operation of a customer's high-pressure system. Read all CAUTIONS and WARNINGS before commencing service or operation of any high-pressure system. The CAUTIONS and WARNINGS are included in each Service Manual and with each Accessory Data sheet. CAUTIONS and WARNINGS can also be viewed online at www.catpumps.com/dynamic-literature/cautions-and-warnings or can be requested directly from Cat Pumps.

WARRANTY

View the Limited Warranty online at www.catpumps.com/literature/cat-pumps-limited-warranty