

DATA SHEET

PRESSURE-SENSITIVE REGULATING UNLOADERS



Stainless Steel Models: 7531, 7533, 7536



Model 7531 Shown

FEATURES

- Provides system pressure control and protection for single or multiple gun applications.
- Maintains full system pressure while running in bypass without full load on pump.
- Multiple ports provide for convenient mounting.
- Color-coded spring aids in easy identification and can be quickly transferred from one model to another.
- Unloader comes standard with NBR O-rings. Alternative O-ring materials are available for higher temperatures or chemical compatibility.

SPECIFICATIONS	U.S.	METRIC
7531		
Flow Range*	1–21 gpm	3.8–80 lpm
Pressure Range	218–2175 psi	15–150 bar
7533		
Flow Range*	1–21 gpm	3.8–80 lpm
Pressure Range	406–4060 psi	28–280 bar
7536		
Flow Range*	1–21 gpm	3.8–80 lpm
Pressure Range	580–5800 psi	40–400 bar

*If fed through the bottom inlet port, the maximum flow rate is 7.92 gpm

COMMON SPECIFICATIONS	U.S.	METRIC
Maximum Temperature (NBR)	140° F	60° C
Inlet Ports (2)	½" NPT(F)	½" NPT(F)
Discharge Port	½" NPT(F)	½" NPT(F)
Bypass Port	½" NPT(F)	½" NPT(F)
Weight	2.93 lbs	1.33 kg
Dimensions	8.75 x 3.75 x 1.75"	223 x 96 x 45 mm

Note: Use only at above specifications to ensure proper unloader life and performance.

🔧 These Pressure-Sensitive Regulating Unloaders can be converted to Secondary Relief Valves. See page 4 for Relief Valve conversion.

ALTERNATIVE O-RING CONFIGURATION

MATERIAL	SUFFIX CODE	MAXIMUM TEMPERATURE	
NBR	—	140° F	(60° C)
FPM	.0110	240° F	(115° C)

Read all CAUTIONS and WARNINGS before commencing service or operation of any high-pressure system

SELECTION

These pressure-sensitive regulating unloaders are designed for systems with single or multiple pumps, solenoid (gate) valves, nozzles, and shut-off or weep guns.

Note: For multiple-pump systems, it is best to use a pressure regulator, not a pressure-sensitive regulating unloader.

These unloaders should meet both the desired system flow (combined nozzle flow rate requirement) and the desired system pressure.

NOTICE Operation below the minimum rated flow of the unloader causes the unloader to cycle. Operation above the maximum rated flow of the unloader causes cycling and premature unloader wear, cycling and preventing achieving the desired system pressure.

INSTALLATION

These unloaders operate properly when mounted in any direction. However, keeping the plumbing to a minimum and the hex adjusting nut easily accessible is preferred. The ideal mounting location is directly on the pump's discharge manifold.

There are two (2) inlet connections on these unloaders. Both are 1/2" NPT(F) ports and are located on the short extension side and bottom. There is an arrow and the word IN marked on the body, indicating the direction of flow. Liquid from the discharge of the pump goes into this connection.

The discharge connection is a 1/2" NPT(F) port located on the front side (hex end). There is an arrow and the word OUT marked on the body, indicating the direction of flow. Plumbing to the spray guns, solenoid (gate) valves or nozzles connect here.

The bypass connection is a 1/2" NPT(F) port located on the side. There is the word BY-PASS marked on the body, indicating the direction of flow. Bypass liquid is directed out of this port and can be routed to a reservoir (preferred method), drain or pump inlet.

OPERATION

These pressure-sensitive regulating unloaders hold established system pressure in the discharge line when the trigger gun or solenoid (gate) valve is closed, or the nozzle is clogged, thus bypassing all unrequired flow. Squeezing the trigger gun or opening the solenoid (gate) valve will close the bypass and return to established system pressure.

PRESSURE ADJUSTMENT

Note: Pressure is not set at the factory.

1. Setting and adjusting the unloader pressure must be done while the system is running.
2. Start the system with unloader backed off to the lowest pressure setting (counterclockwise direction).
3. Increase the unloader pressure setting by turning the hex adjusting nut clockwise.
4. Squeeze the trigger and read the pressure on the gauge at the pump.

Note: Do not read the pressure at the gun or nozzle.

5. If more pressure is desired, release the trigger, turn hex adjusting nut one quarter turn in clockwise direction.
6. Squeeze the trigger and read the pressure.
7. Repeat this process until desired system pressure is reached.
8. If desired system pressure cannot be reached, review TROUBLESHOOTING chart.

NOTICE A secondary pressure safety relief device (e.g. pop-off valve, relief valve) should be used along with this pressure-sensitive regulating unloader. Final adjustment for the secondary relief valve should be approximately 200 psi above the system operating pressure.

Note: A minimum of 5% of the flow through the unloader should bypass for proper regulator performance. If the entire unloader flow pumps through the nozzle (zero-bypass), the valve can easily be set for pressure higher than the desired pressure, causing a malfunction or premature wear

Note: By removing the check valve and spring, these unloaders can function as secondary relief valves.

 See page 4 for Relief Valve conversion.

TYPICAL UNLOADER INSTALLATION

1. Pressure Gauge
2. Relief Valve
(Secondary Pressure Relief Valve)
3. Pulsation Dampener
4. **Pressure Sensitive Regulating Unloader**
(Primary Pressure Regulating Device)
5. Triplex Plunger Pump

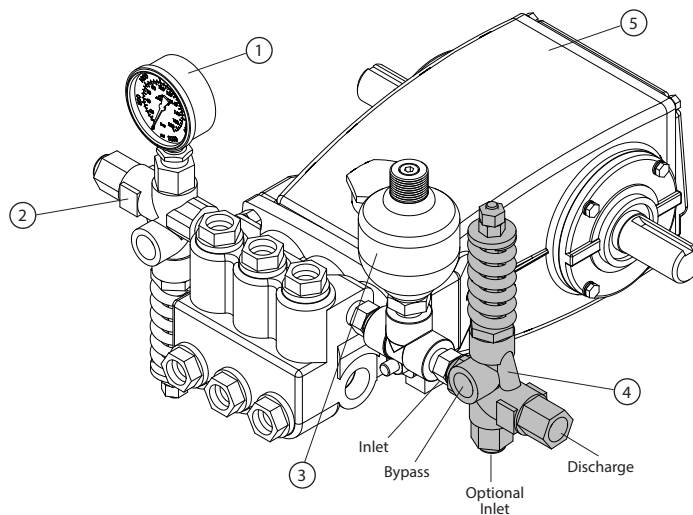

SERVICING

Disassembly

1. Disconnect bypass, discharge and inlet plumbing from unloader.
 2. Remove unloader from pump.
 3. Secure body of unloader in a vise with hex adjusting nuts facing up.
 4. Remove discharge fitting and O-ring, spring and check valve with O-ring.
 5. Examine check valve and discharge fitting for wear, spring for wear or fatigue, and O-rings for cuts or wear. Replace as needed.
- Note:** While the discharge fitting is removed, inspect sealing area for grooves, pitting and wear. Where the check valve makes contact within the internal body of the unloader. If damage is found, stop the repair and replace with complete new unloader. No damage is found, proceed with disassembly.
6. Remove two (2) hex adjusting nuts by turning in a counterclockwise direction.
 7. Remove spring retainer and spring.
 8. Examine spring and spring retainer for scale build up, fatigue or wear and replace as needed.
 9. Use wrench to unthread and remove piston retainer and piston stem together from main unloader body.
 10. Examine piston stem and piston retainer for scale build up, scoring, pitting and wear, and replace as needed. Examine O-rings and backup rings for cuts or wear. Replace as needed.
 11. Remove unloader body from vise and reposition in vise with bottom inlet port facing up.
 12. Remove inlet fitting with O-ring, seat, spring and ball.
 13. Remove unloader body from vise and reposition in vise with bottom inlet port facing down.
 14. Drive out seat and O-ring from the top side.
 15. Examine seat, seat spring and ball for scale build up, scoring and wear and replace as needed. Examine O-rings for cuts or wear. Replace as needed.

Reassembly

1. Remove unloader body from vise and reposition in vise with bottom inlet port facing up.
2. Lubricate and install O-ring onto outside diameter of seat.
3. Place seat with O-ring into unloader body with small inside diameter hole facing up.
4. Place ball onto seat and then spring.
5. Lubricate and install O-ring onto inlet fitting. Thread in inlet fitting by hand and tighten.
6. Remove unloader body from vise and reposition in vise with bottom inlet fitting facing down.
7. Lubricate and install O-ring and then backup ring over threaded end of piston stem small diameter groove.
8. Install backup ring, O-ring and then backup ring on opposite end of threaded piston stem. Lubricate all parts.
9. Lubricate and install O-ring onto piston retainer.
10. Place threaded end of piston retainer over the threaded end of the piston stem.
11. Place piston retainer and piston stem assembly into unloader body with threaded end of piston stem facing up. Thread piston retainer into unloader body by hand and tighten with wrench.
12. Apply Loctite® 242® to the bottom threads of the piston stem.
13. Hand thread one (1) hex nut onto piston stem and tighten with wrench.
14. Place spring over piston stem, followed by positioning the spring retainer onto spring with stepped surface facing down.
15. Hand thread two (2) hex nuts onto piston stem.
16. Lubricate O-ring on check valve. Insert check valve with O-ring facing into unloader body. Place spring onto check valve.
17. Lubricate O-ring on discharge fitting. Hand thread into unloader body and tighten with wrench.
18. Remove unloader from vise.
19. Re-install unloader onto pump.
20. Reconnect bypass, discharge and inlet plumbing to unloader.
21. Proceed to PRESSURE ADJUSTMENT.

Loctite® and 242® are registered trademarks of the Henkel Corporation.

TROUBLESHOOTING

Unloader cycles	<ul style="list-style-type: none"> • Check valve O-ring worn out • Fitting leaking downstream • Worn O-ring inside gun • Insufficient flow through unloader
Liquid leaking from bottom	<ul style="list-style-type: none"> • Seat or inlet fitting O-ring is cut or worn
Liquid leaking from middle	<ul style="list-style-type: none"> • Piston O-ring is cut or torn
Unloader will not come up to pressure	<ul style="list-style-type: none"> • Not properly sized for system pressure • Foreign material in unloader • Piston O-rings are worn • Nozzle worn or sized incorrectly • Jam nuts not properly set
Extreme pressure spikes	<ul style="list-style-type: none"> • Adjusting handle turned completely into unloader • Restricted bypass or no bypass • System flow exceeds unloader rating

PARTS LIST

ITEM	MODEL NUMBER			MATL	DESCRIPTION	QTY
	7531	7533	7536			
401	33045	33045	33045	NY	Handle, Adjustment	1
403	—	—	—	S	Nut, Hex Adjusting (M10)	3
408	32323	—	—	STL	Spring—White (400–2200 psi)	1
	—	32324	—	STL	Spring—Blue (800–4000 psi)	1
	—	—	32344	STL	Spring—Black (3000–6000 psi)	1
410	30119	30119	30119	BB	Retainer, Spring	1
412	32339	32339	32339	S	Stem, Piston	1
	34586	34586	34586	SS	Stem, Piston (Not Shown)	1
414	—	—	—	PTFE	Backup Ring, Piston Stem	1
415	—	—	—	NBR	O-Ring, Piston Stem—90D	1
425	39055	39055	39055	S	Retainer, Piston	1
426	32326	32326	32326	S	Pin, Piston Lock	1
428	32926	32926	32926	NBR	O-Ring, Piston Retainer—85D	1
429	—	—	—	NBR	O-Ring, Piston Stem	1
430	—	—	—	PTFE	Backup Ring, Piston Stem	2
434	32325	32325	32325	S	Spring, Seat	1
435	32327	32327	32327	S	Ball and Seat Assembly	1
437	—	—	—	NBR	O-Ring, Seat—90D	1
439	32926	32926	32926	NBR	O-Ring, Inlet Fitting—85D	1
440	—	—	—	S	Body	1
441	—	—	—	NBR	O-Ring, Check Valve	1
443	32338	32338	32338	S	Valve, Check with NBR O-Ring	1
444	32332	32332	32332	S	Spring, Check Valve	1
446	32926	32926	32926	NBR	O-Ring, Discharge Fitting—85D	1
455	32342	32342	32342	S	Fitting, Inlet (½" NPT[F])	1
460	32345	32345	32345	S	Fitting, Discharge (½" NPT[F])	1
462	—	—	—	S	Plug, Inlet	1
468	32346	32346	32346	NBR	Kit, (Includes: 414, 415, 428, 429, 430, 437, 439, 441, 446)	1
	33346	33346	33346	FPM	Kit, (Includes: 414, 415, 428, 429, 430, 437, 439, 441, 446)	1

Bold print part numbers are unique to a particular model.

Italics are optional items.

MATERIAL CODES (Not Part of Part Number): BB=Brass FPM=Fluorocarbon
NBR=Medium Nitrile (Buna-N) NY=Nylon PTFE=Pure Polytetrafluoroethylene
S=304SS SS=316SS STL=Steel

EXPLODED VIEW

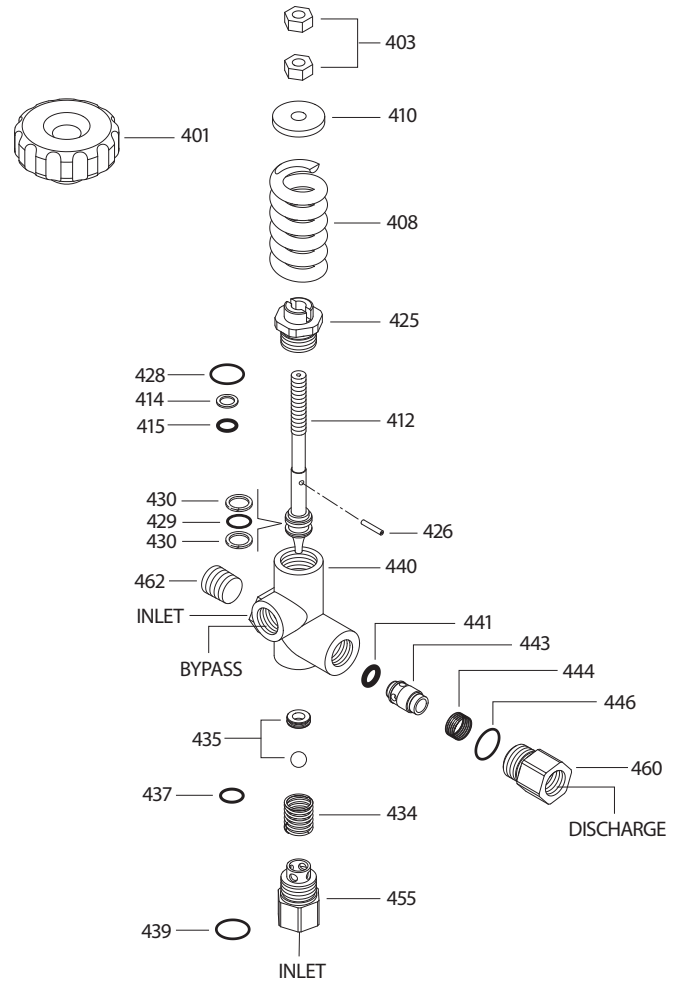

REGULATING UNLOADER TO RELIEF VALVE CONVERSION

The 7531, 7533 and 7536 Pressure-Sensitive Regulating Unloaders are typically used as a primary pressure regulating device. They can be converted to a Relief Valve to be used as a secondary pressure relief device by removing the discharge check valve, O-ring and spring.

Unloader PN	Modifications	Converted Relief Valve PN	
7531	Remove parts 441, 443, 444	7531.100 (NBR Seals)	7531.1110 (FPM Seals)
7533		7533.100 (NBR Seals)	7533.1110 (FPM Seals)
7536		7536.100 (NBR Seals)	7536.1110 (FPM Seals)

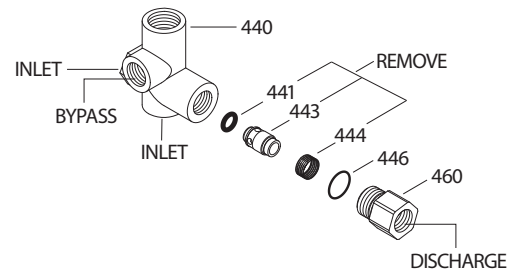

CAUTIONS AND WARNINGS

All high-pressure systems require a primary pressure regulating device (e.g. regulator, unloader) and a secondary pressure relief device (e.g. pop-off valve, relief valve). Failure to install such relief devices could result in personal injury or damage to pump or property. Cat Pumps does not assume any liability or responsibility for the operation of a customer's high-pressure system. Read all CAUTIONS and WARNINGS before commencing service or operation of any high-pressure system. The CAUTIONS and WARNINGS are included in each Service Manual and with each Accessory Data sheet. CAUTIONS and WARNINGS can also be viewed online at www.catpumps.com/dynamic-literature/cautions-and-warnings or can be requested directly from Cat Pumps.

WARRANTY

View the Limited Warranty online at www.catpumps.com/literature/cat-pumps-limited-warranty